

DEPARTMENT OF THE ARMY TECHNICAL MANUAL

---

ORGANIZATIONAL, DS, GS, AND DEPOT MAINTENANCE MANUAL

CRANE-SHOVEL, BASIC UNIT, TRUCK MOUNTED: 20 TON

3/4 CU. YD., GASOLINE ENGINE, 6x6 (AMERICAN  
HOIST AND DERRICK MODELS) MODEL 2360 (NON-  
WINTERIZED) FSN 3810-989-0505 MODEL W2360  
(WINTERIZED) FSN 3810-989-0506

---

This copy is a reprint which includes current  
pages from Changes 1,2,4 and 5.

HEADQUARTERS, DEPARTMENT OF THE ARMY

DECEMBER 1964

## **SAFETY PRECAUTIONS**

### **Before Operation**

Always report or correct any conditions that may result in injury to personnel if operation is to be continued. Disengage the master clutch before greasing, oiling, or making adjustments on the crane.

Keep the equipment free of grease, oil, and dirt. Always block the wheels of the carrier when parking on a grade, no matter how slight.

See that all adjustments are properly made and never operate a machine that is not properly adjusted.

Do not work on the engine unless the ignition switch is in the OFF position.

Do not fill the fuel tank while the engine is running.

When handling gasoline, always provide a metallic contact between the container and the tank. This will prevent a spark from being generated as gasoline flows over the metallic surfaces.

Before starting the engine, make certain the master clutch lever is disengaged.

Do not allow open flame or smoking around flammable material or when servicing the batteries.

### **During Operation**

Always report or correct any conditions that may result in injury to personnel if operation is to be continued.

Avoid careless operating habits which will cause accidents to personnel. Keep the equipment free of grease, oil and dirt.

Watch the load while it is moving. Stop operation at once when looking in another direction. When dumping into trucks, spot the trucks so the swing will be over the tailgate of the truck. Never swing over the truck cab.

Always keep loaded buckets and crane loads within the safe working range, and keep sufficient clearance from high tension electric wires.

Keep the equipment on a firm base while operating, or use mats under the carrier.

Do not take chances on worn or frayed cables; replace them at once.

Do not allow personnel in the cab or on the load while the equipment is in operation.

Never lift a load unless it is hooked properly. Use sufficient line in hook to handle the load.

When making heavy lifts with a high boom, use extreme care and try the load after lifting it off the ground to see that the brakes will hold the load. Never move loads over personnel or equipment.

Do not operate the engine in a closed building unless the exhaust gas is piped to the outside. The exhaust gases contain carbon monoxide, a colorless, odorless, deadly poison.

Do not fill the fuel tank while the engine is running.

When handling gasoline, always provide a metallic contact between the container and the tank. This will prevent a spark from being generated as gasoline flows over metallic surfaces,

When the crane is being operated, the main transmission gearshift lever should be moved to neutral position and the handbrake set.

### **After Operation**

Always report or correct any conditions that may result in injury to personnel if operation is to be continued.

Never leave the crane or shovel with the bucket, or any crane load in a raised position. The brake may loosen just enough to cause the load to fall or allow the front end attachment to lower on personnel.

Keep the equipment free of grease, oil, and dirt. Do not leave the equipment on a bank or unstable parking place overnight.

Do not work on the engine unless the ignition switch is in the OFF position.

Do not fill the fuel tank while the engine is running. When handling gasoline always provide a metallic contact between the container and the tank. This will prevent a spark from being generated as gasoline flows over the metallic surfaces.

Change }  
No. 5 }

HEADQUARTERS  
DEPARTMENT OF THE ARMY  
Washington, D.C., 16 May 1973

**Operator, Organizational, Direct Support,  
General Support, and Depot Maintenance Manual**

**CRANE-SHOVEL, BASIC UNIT, TRUCK MOUNTED:**

**20 TON, 3/4 CU. YD., GASOLINE ENGINE, 6 X 6**

**(AMERICAN HOIST AND DERRICK MODELS)**

**MODEL 2360 (NON-WINTERIZED) FSN 3810-989-0505**

**MODEL W2360 (WINTERIZED) FSN 3810-989-0506**

TM 5-3810-227-15, 10 December 1964, is changed as follows:

*Page 8.* In paragraph 6a(2), the following is added: "Compression: 115-135 psi".

*Page 17.* Paragraph 10.1 is added after paragraph 10.

**10.1. Equipment Conversion**

*a. General.* The basic crane-shovel may be converted to various uses by changing front end attachments. After conversion the crane-shovel may be referred to as a crane, clamshell, dragline, backhoe, or a shovel. When a conversion is expected, make sure all required attachments, tools, blocking, personnel and a suitable lifting device are available to begin the job. The various conversions are described in paragraphs 11 through 11.5.

*b. Cable Drums and Lagging.* Cable lagging consists of two halves for each cable drum. The lagging is bolted to the cable drums with countersunk machine screws. For crane, clamshell, shovel, backhoe, and piledriver operations, 15-inch lagging is used on both drums. The left cable drum operates the hoist line for all attachments. The right cable drum operates the backhoe and dragline pull cable and the clamshell closing line. During shovel operation the right cable drum remains idle. *Page 18.* Paragraph 11c.1 is added after paragraph 11c.

c.1 Crane Boom Jib Installation and Removal. Refer

to figure

**8.1. and install and remove the crane boom job.**

Figure 8.1 is added.

Paragraphs 11.1 through 11.5 are added after paragraph 11.

**11.1. Shovel Conversion**

*a. General.* The basic front end components (fig. 9.1) required to convert to shovel operation are the boom, dipper stick, padlock sheave, shipper shaft, saddle bucket, crowd cable, crowd mechanism, sprocket, dipper trip, and cables. The bucket is attached to the end of the dipper stick which slides through the saddle located near the center of the boom.

*Page 20.* Figure 9.1 is added:

*b. Shovel Installation.*

(1) Using a suitable lifting device, lift the boom in position and aline the holes in the shovel boom foot with the holes in the revolving super-structure frame (fig. 9.2).

(2) Install boom foot pins to secure boom to superstructure.

(3) Install sprocket for crowd drum drive chain on auxiliary shaft and install drive chain.

(4) Install proper shovel lagging.

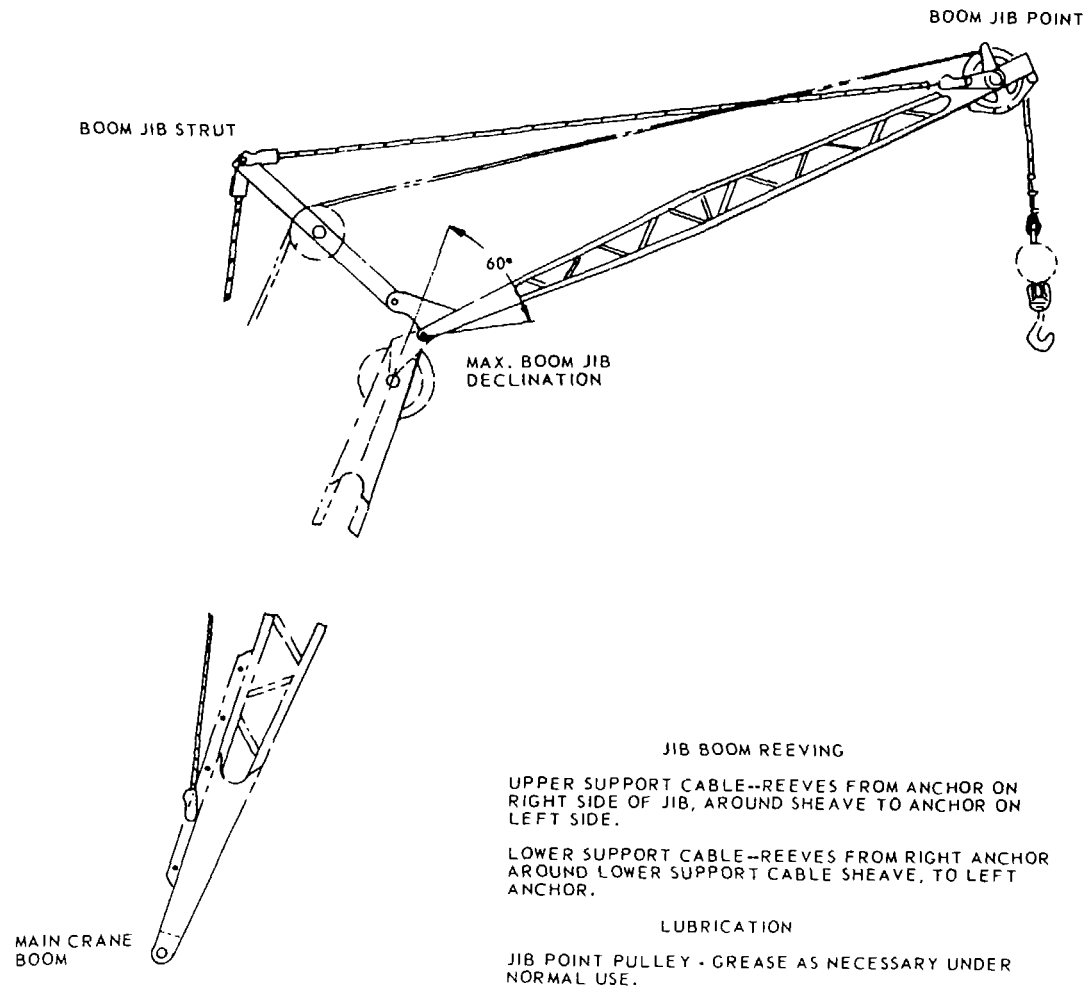

ME 3810-227-15 '8.1 C5

**Figure 8-1. Crane boom jib, 15-foot assembly for 3/4 cubic yard crane shovel, removal and installation.**

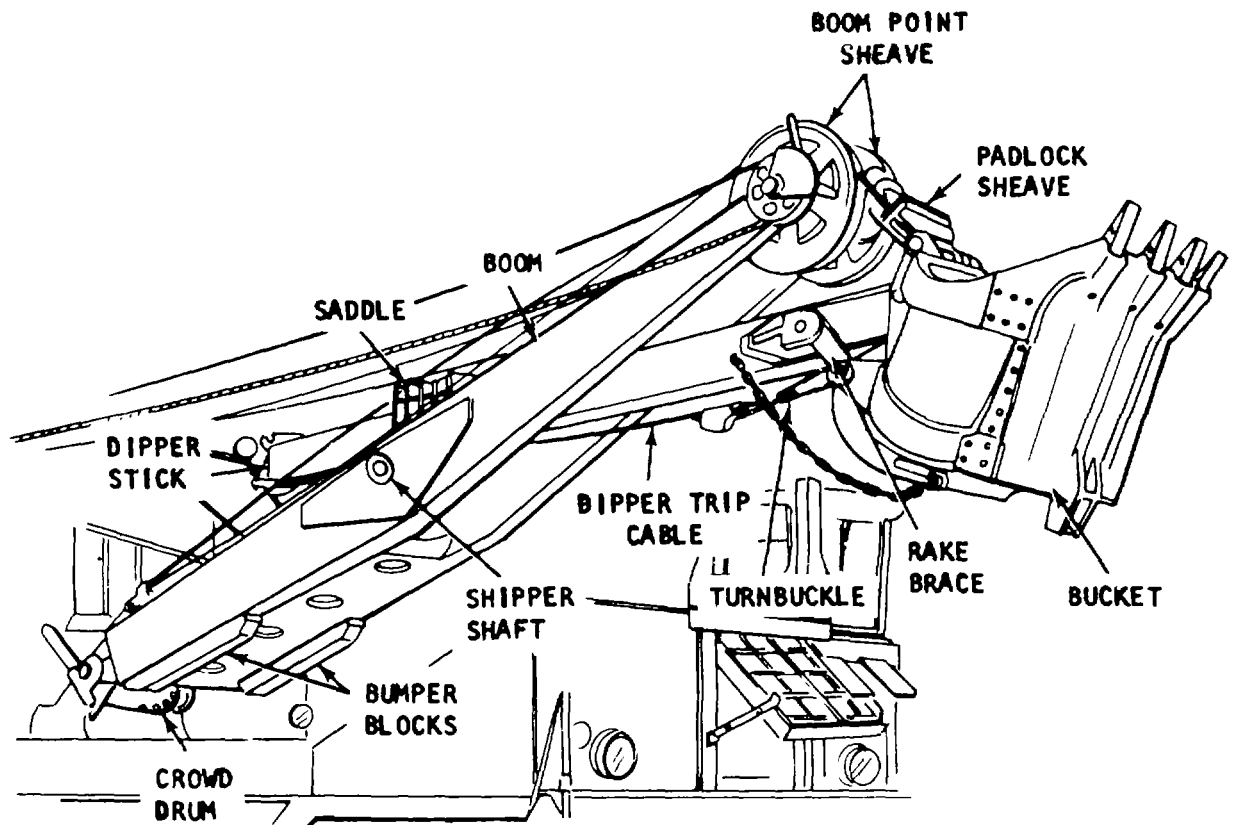

ME 3810-227-15/9.1 C5

Figure 9-1. Shovel attachment.

(5) Install dipper trip assembly and dipper trip wiring as instructed in figure 9.3.

(6) Install and reeve cables as instructed in figure 9.4.

(7) Raise boom to operating level and adjust crowd and retract cable tension with turnbuckle (fig. 9.2). Figures 9.2, 9.3, and 9.4 are added:

*c. Shovel Removal*

(1) Retract the shovel bucket and lower shovel boom to a horizontal position. Build up cribbing under boom as shown in figure 9.5.

(2) Refer to figure 9.2 and remove crowd drive chain, power trip cable, and cables.

(3) Use a suitable lifting device to hold boom and remove boom foot pins and move carrier away from cribbed boom.

(4) Remove drive sprocket and shovel lagging (fig. 9.2).

Figure 9.5 is added:

**11.2. Backhoe Conversion**

*a. General.* The crane-shovel may be converted to backhoe operation by installing the backhoe front end attachment. The backhoe attachment (fig. 9.6) consists of a one-piece welded boom, bucket arm, bucket, bucket padlock, boom roller; bail assembly, A-frame, and backstop. The bucket is attached to the bucket arm which pivots at the end of the boom. An A-frame is attached at the foot of the boom to support the hoist cables. The boom is attached to the revolving frame by, foot pins. Figure 9.6 is added:

*b. Backhoe Installation.*

(1) Assemble adapter plates and back stop to A-frame and lift assembly into position. Install pin in front gantry leg as illustrated in figure 9.7.

(2) Using a suitable lifting device, lift boom section into place and secure with boom foot pins.

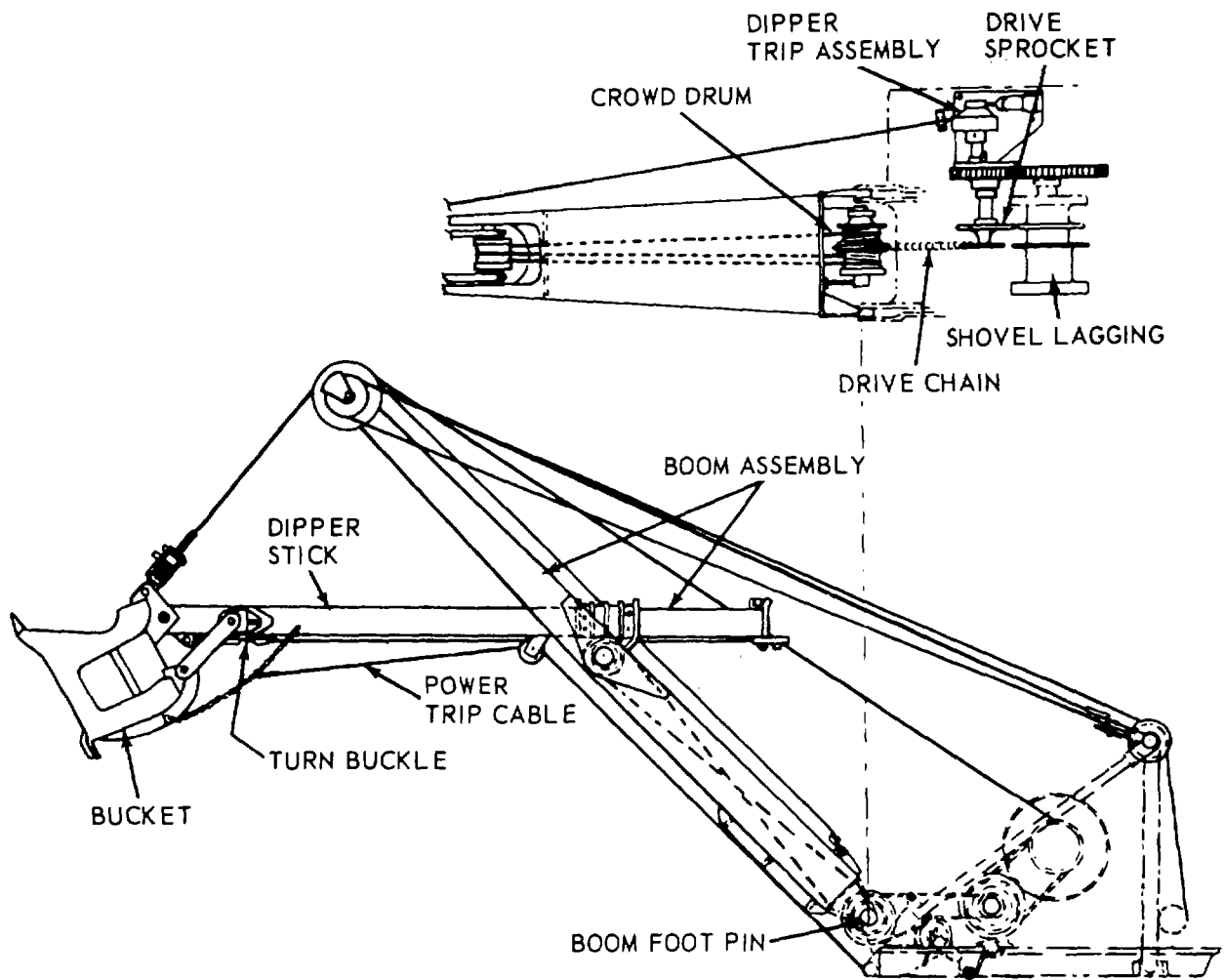

ME 3810-227-15/9.2 C5

Figure 9-2. Shovel attachment, installation and removal.

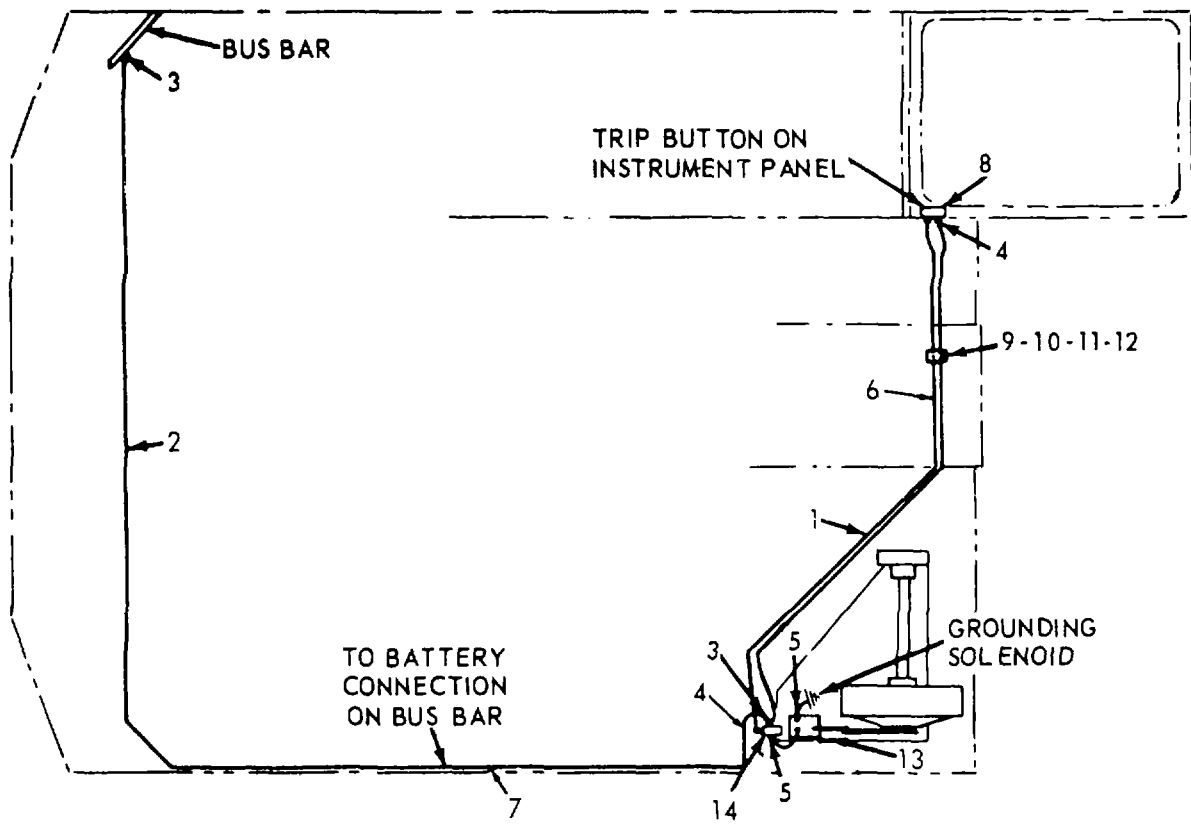

- |   |             |    |                 |
|---|-------------|----|-----------------|
| 1 | Wire 14 TW  | 9  | Cable strap     |
| 2 | Wire 6 TW   | 10 | Machine screw   |
| 3 | Terminal    | 11 | Hex nut         |
| 4 | Terminal    | 12 | Lockwasher      |
| 5 | Terminal    | 13 | Solenoid        |
| 6 | Loom        | 14 | Magnetic switch |
| 7 | Loom        |    |                 |
| 8 | Push button |    |                 |

ME 3810-227 15/9.3 C5

Figure 9.3. Dipper trip wiring diagram.



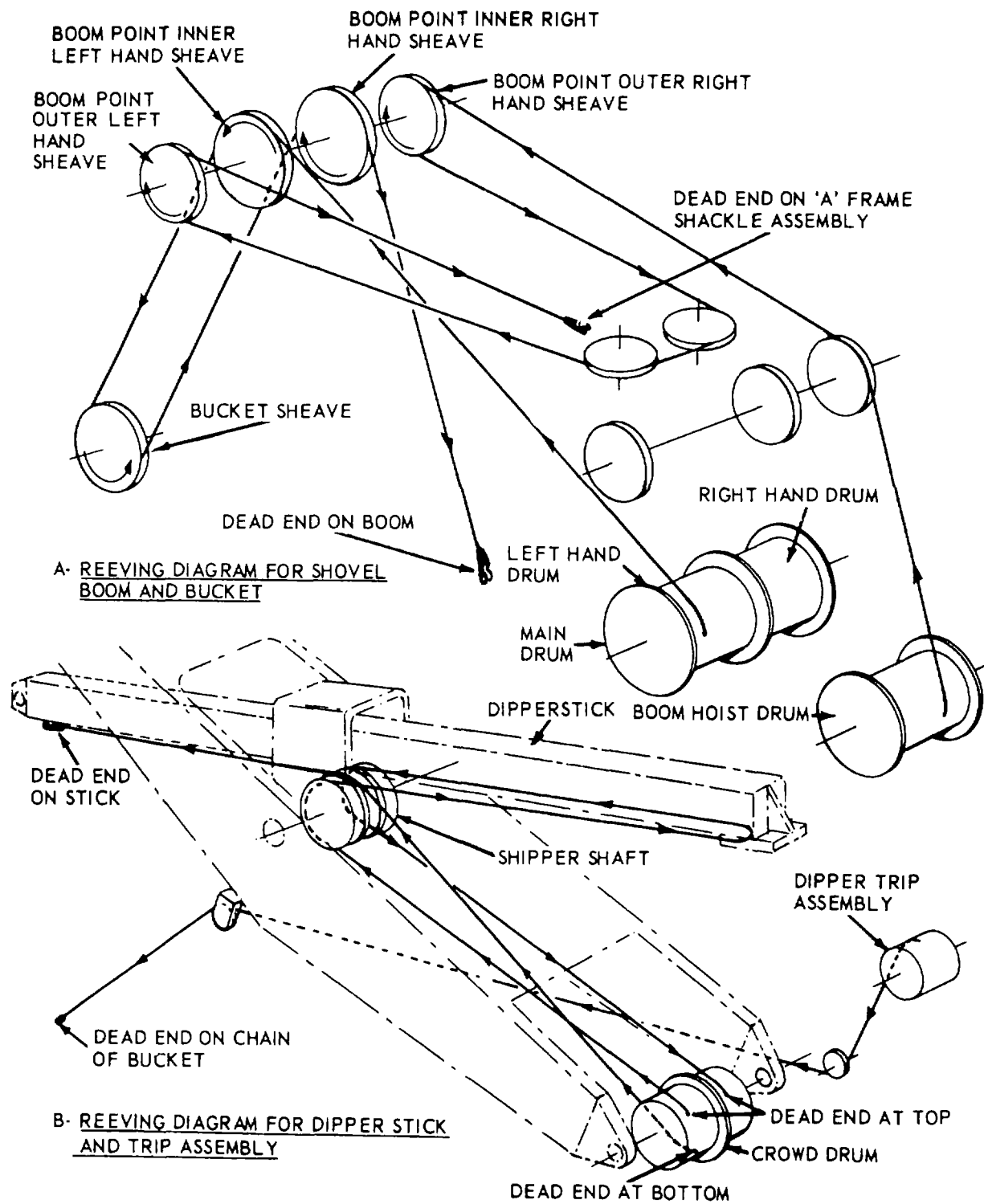

ME 3810-227-15/9.4 C5

Figure 9.4. Shovel cable reeving diagram.

WARNING: MAKE SURE CRIBBING IS SET ON FIRM GROUND TO AVOID UPSETTING OF SHOVEL BOOM, CAUSING INJURY TO PERSONNEL AND DAMAGE TO ATTACHMENT.

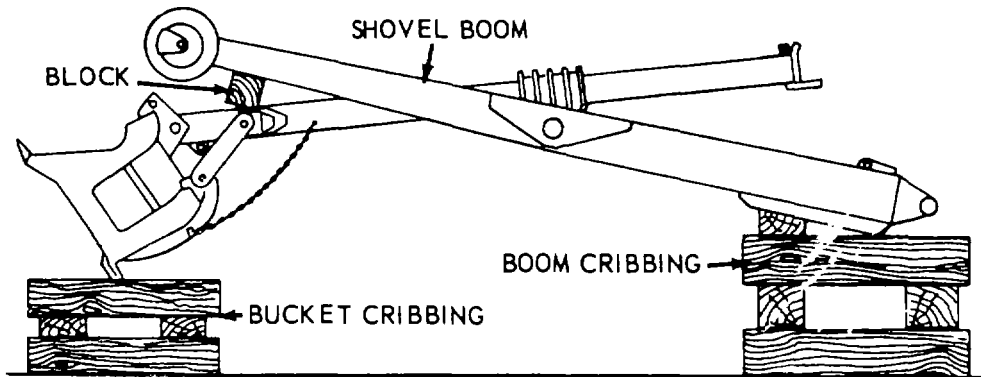

ME 3810-227-15/9.5 C5

Figure 9.5. Shovel boom cribbing method.

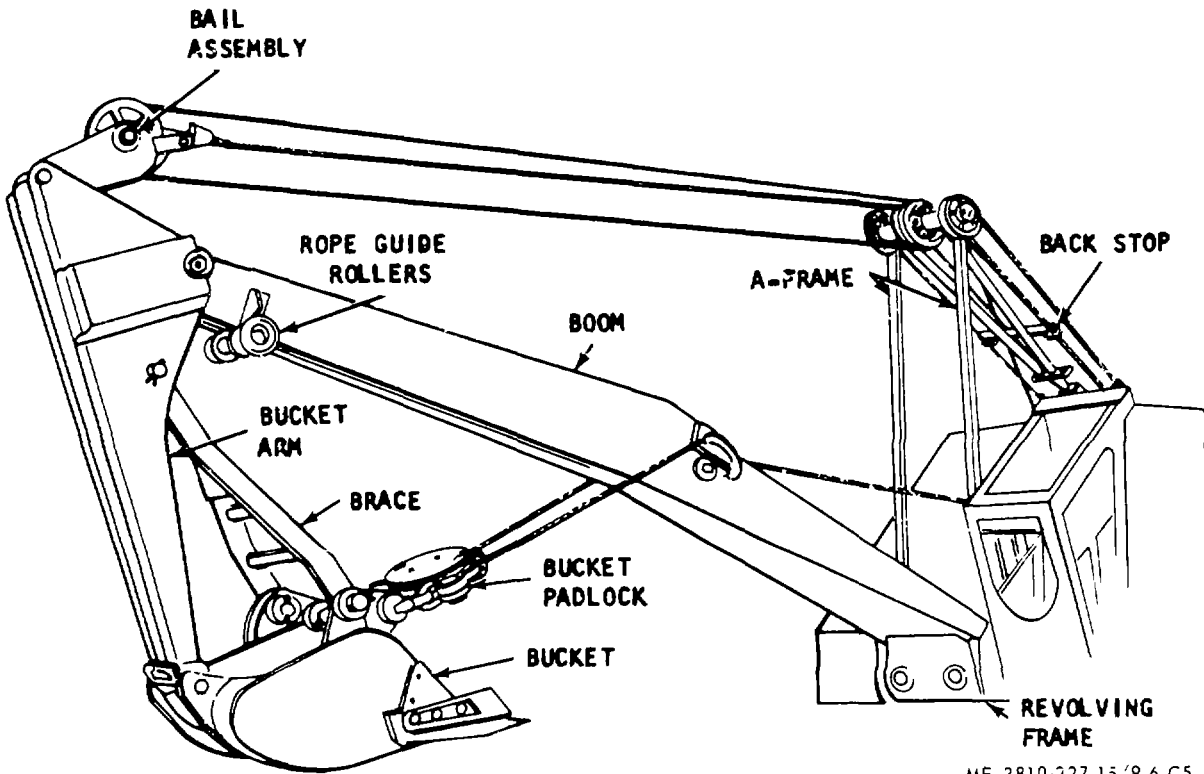

ME 3810-227-15/9.6 C5

Figure 9.6. Backhoe attachment.

(3) Install bucket arm, bucket and brace, securing with their respective pins.

(4) Install and reeve cables as instructed in figure 9.8.

**NOTE**

**When putting backhoe in operation, the A-frame should be raised until the spring in the backstop assembly has just started to compress.**

Figures 9.7 and 9.8 are added:

*c. Backhoe Removal.*

(1) Extend the hoe bucket and lower the boom. Build up cribbing under bucket so that when boom is lowered the bucket assembly will rest on the cribbing (fig. 9.9).

(2) Lower the A-frame so it will rest on the boom.

(3) Remove the cables.

(4) With a suitable lifting device, lift the boom foot enough to remove the boom foot pin.

(5) Move the carrier away from the boom and build crib under boom foot (fig. 9.9).

Figure 9.9 is added:

**11.3. Dragline Conversion**

*a. General.* The basic crane-shovel may be

converted to dragline operation for excavating materials below ground level. The basic components for conversion are the crane boom, fair-lead, one 12-inch cable drum lagging for the right cable drum, drag cable, and dragline bucket. The crane hoist cable may be used for hoisting the dragline bucket but, if additional reach and depth are desired, a longer cable must be installed.

*b. Installing and Reeving the Dragline.*

(1) Install the crane boom (para 11).

(2) Install the fair-lead at the base of the boom between the cord angles, and secure in place with the 4 U-bolts and 8 nuts and lockwashers.

(3) Reeve the crane hoist cable (fig. 9.10) over the center boom point sheave and secure it to the left cable drum. Reeve the remaining free end to the hoist cable socket of dragline bucket.

**NOTE**

**When inserting the cable end back into the cable socket, do not let it protrude on the opposite side more than one inch.**

(4) Reeve the drag cable through the fair-lead sheaves back to the drag drum and secure it to the drum.

(5) Reeve the remaining free end through the three-way socket (fig. 9.10) and secure it.

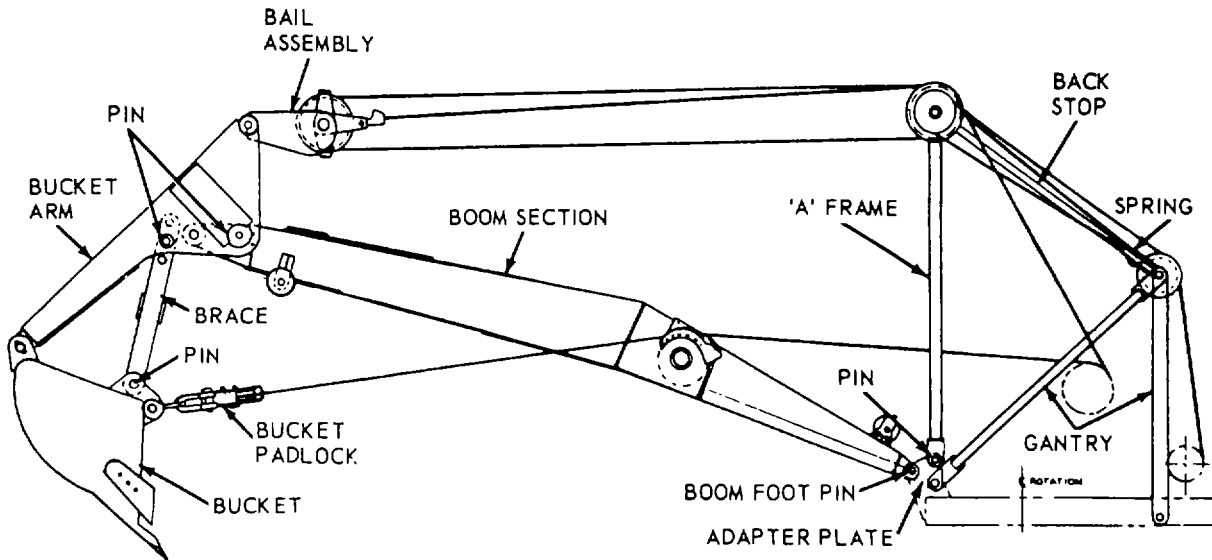

ME 3810-227-15/9.7 C5

**Figure 9-7. Backhoe attachment, removal and installation.**

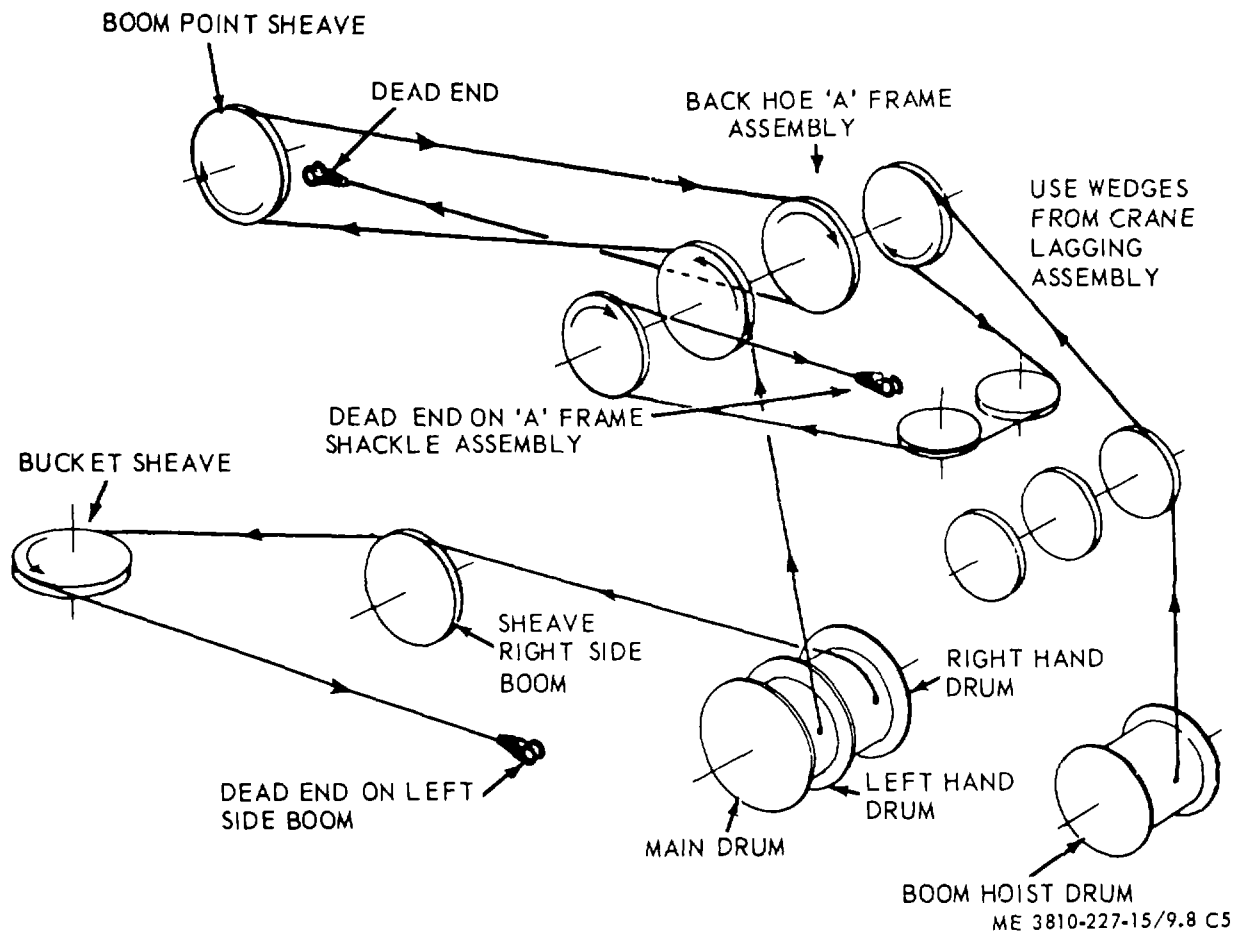

**Figure 9.8. Backhoe cable reeving diagram.**

(6) Spool the slack cable on the cable drums.

Figure 9.10 is added:

*c. Removing and Unreeving the Dragline.*

(1) Place the dragline bucket in the desired position and set it down on wood blocking.

(2) Release the cable drum brakes and spool the cable off the hoist and drag drums (fig. 9.10). Remove the cable wedge from the drum sockets, and pull the cable free of the drums, fair-lead, and center boom point sheaves.

(3) Remove the cable wedge from the three-way socket and hoist cable socket and pull the cable free of the dragline bucket.

(4) Coil each cable neatly and secure with wire. Lubricate cables in accordance with the current lubrication order and label for future use.

(5) Remove the fair-lead by removing the 8

nuts and lockwashers and 4 U-bolts.

(6) Remove the crane boom (para 11).

*d. Dragline Bucket Dump Cable.*

(1) *Installation and Reeving.* Insert one end of the bucket dump cable (fig. 9.10) through the three-way socket and secure with the cable wedge. Reeve the remaining free end over the dump sheave, down to the bucket arch, and dead-end the cable.

(2) *Adjustment.* Remove the dump cable from the dead-end socket on top of the bucket arch and lengthen or shorten it as necessary. The bucket teeth should be about 12 inches higher than the heel of the bucket when the bucket is suspended in midair and the dragline cable pulled tight.

(3) *Removal and Unreeving.* Remove the cable wedge from the three-way socket and the dead-end socket on the bucket arch. Unreeve the bucket

WARNING: MAKE SURE CRIBBING IS SET ON FIRM GROUND TO AVOID UPSETTING OF BACK HOE, CAUSING INJURY TO PERSONNEL AND DAMAGE TO ATTACHMENT

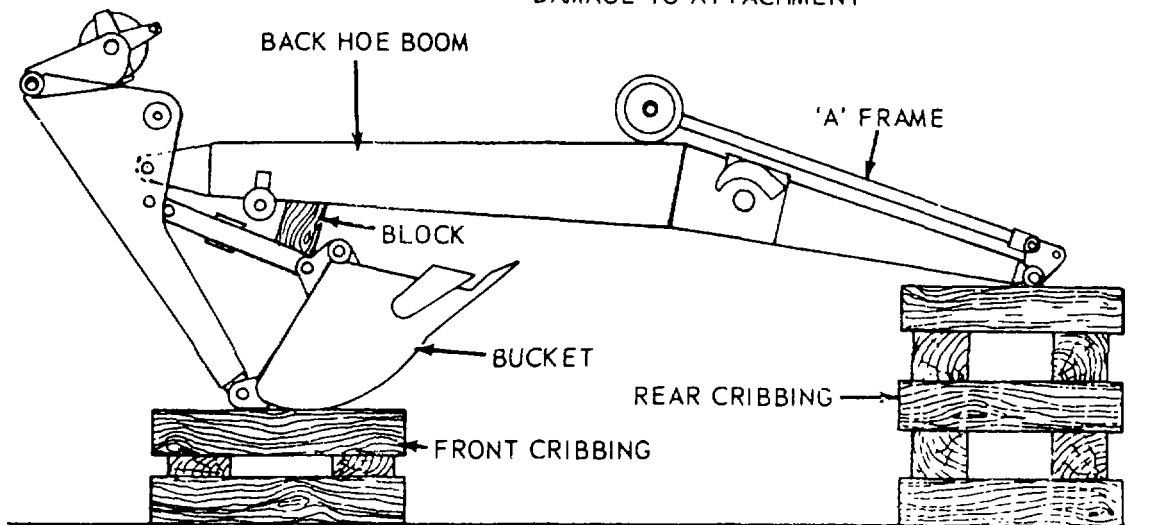

ME 3810-227-15/9.9 C5

Figure .9.9. Backhoe cribbing method.

dump cable from the dump sheave. Coil the cable neatly, lubricate it in accordance with the current lubrication order, and label it for future use.

#### 11.4. Clamshell Conversion

a. *General.* The basic crane-shovel may be converted to clamshell operation for excavating above or below ground level. The basic components for conversion are the crane boom, 15-inch cable drum lagging for both the right and left cable drums, tag line, and bucket holding and closing lines. The crane hoist cable may be used for the bucket holding line, but if additional depth below ground level is desired a longer holding and closing line must be installed.

##### b. *Reeving the Clamshell.*

- (1) Install the crane boom (para 11).
- (2) Swing the crane over the clamshell to be installed.
- (3) Lower the boom to within about 6 feet above the ground beside the clamshell.
- (4) Reeve the clamshell holding cable (fig. 9.11) up and over the left boom point sheave, down the

boom to the left cable drum, and secure to the drum.

(5) Reeve the remaining free end of the cable through the dead-end socket on top of the clamshell and secure with a cable wedge.

(6) Reeve the closing cable up and over the right boom point sheave, down the boom to the right cable drum, and secure to the cable drum.

(7) Reeve the remaining free end of the cable through the cable guide rollers on top of the clamshell, down and around the sheave, up and around the sheave, down through the dead-end socket, and secure the cable with a cable wedge.

(8) Spool the slack cable on the cable drum.

Figure 9.11 is added:

##### c. *Reeving the Tag Line Winder.*

(1) With a suitable lifting device, lift the tag line winder (fig. 9.11) up, and slide it through between the boom cord angles of the base section of the boom, about 3 feet from the center splice.

(2) Secure the tag line winder to the boom with a U-bolt, 4 bolts, lockwashers and nuts.

(3) Reeve the tag line cable through the guide

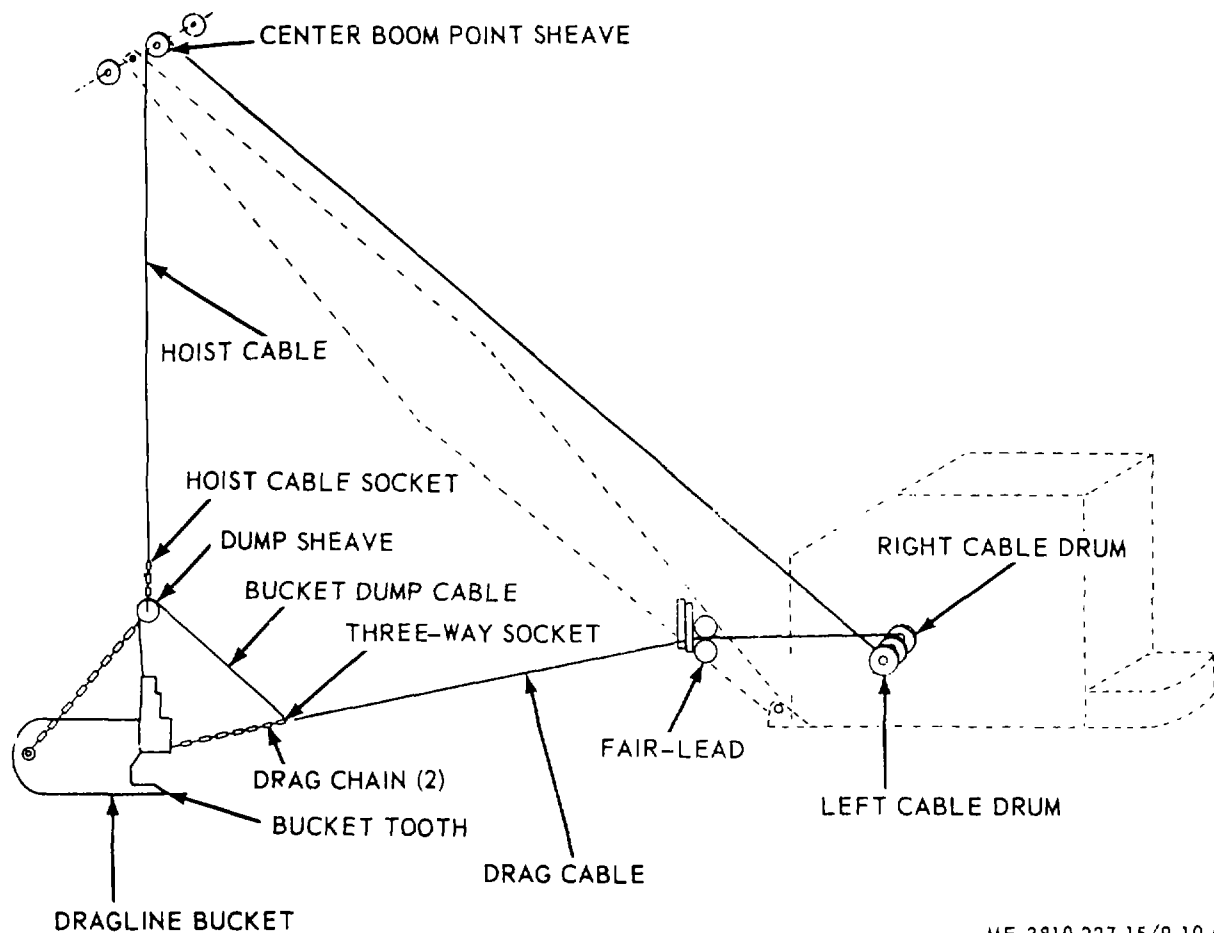

ME 3810-227-15/9.10 C5

Figure 9.10. Dragline reeving diagram.

rollers and out to the clamshell; secure to the bridle chain with cable clamps.

d. *Adjusting the Tag Line Winder.* The tension of the tag line winder cable may be increased or decreased as necessary to prevent oscillation of the clamshell. Add wraps to the tag line reel to increase cable tension; remove wraps to decrease cable tension.

e. *Unreeving the Tag Line Winder.*

(1) Raise the boom until the bucket can be placed on the ground about 10 feet from the base of the boom to relieve the spring tension on the tag line winder.

(2) Remove the cable from the clamshell bridle chain by removing the cable clamps.

#### CAUTION

**Do not release the tag line suddenly; to do so may cause damage to the tag line winder.**

(2) Release the tag line slowly by holding a slight tension on it until all of the cable is taken up on the reel and the end is fastened to prevent the reel from unwinding.

#### NOTE

**The tag line winder may be left on the boom when not in use.**

(4) Remove the nuts, lockwashers, bolts, and U-bolt, and with a suitable lifting device remove the tag line winder from the boom.

f. *Unreeving the Clamshell.*

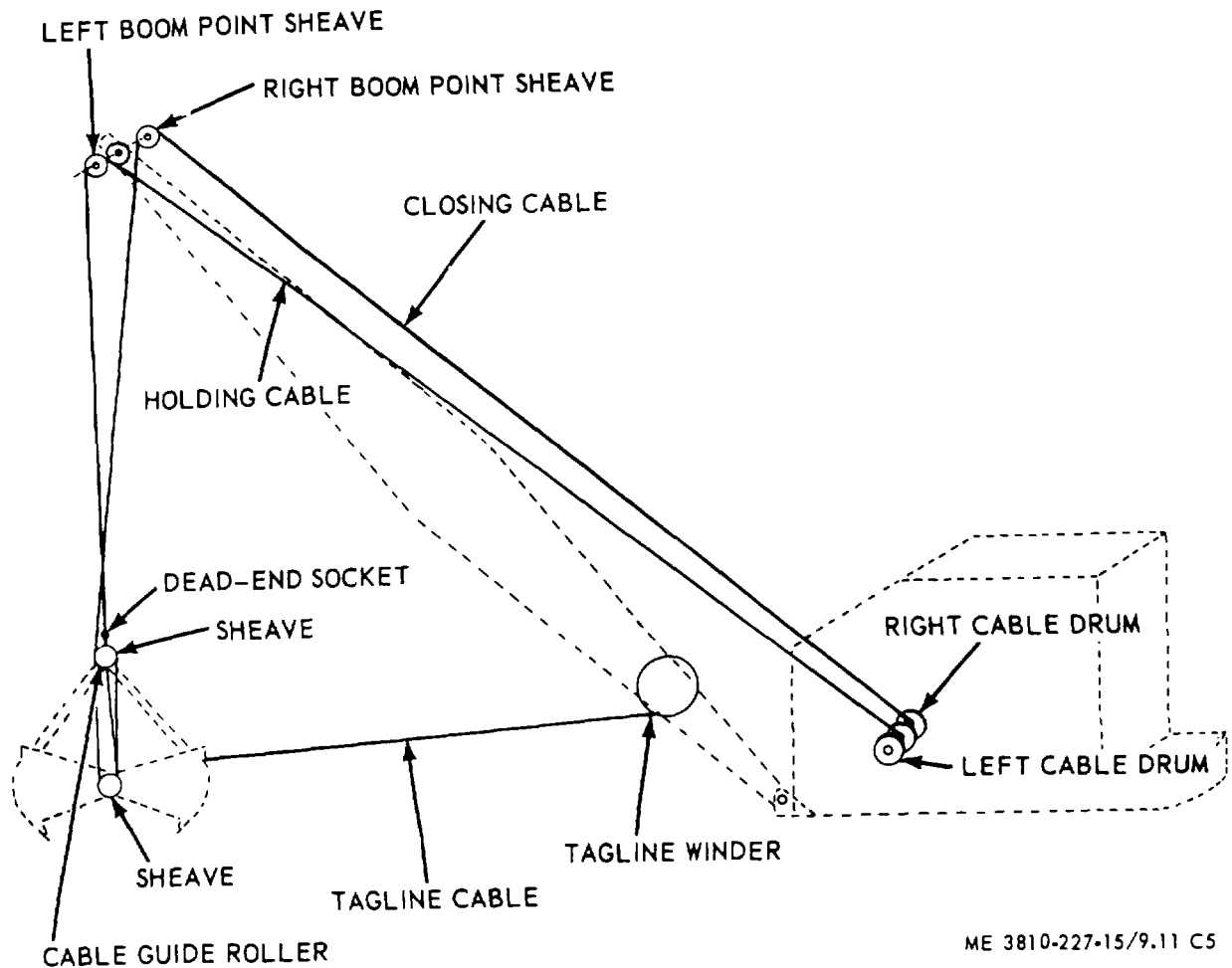

**Figure 9.11. Clamshell receiving diagram.**

- (1) Put the clamshell in a suitable place for storage.
- (2) Unspool the holding and closing cables from the right and left cable drums.
- (3) Remove the cable wedges from the dead-end sockets on the clamshell, and remove the closing and holding cables.
- (4) Remove the cable wedges from both cable drums, and free the closing and holding cables.
- (5) Unreeve the holding and closing cables from the boom point sheaves.
- (6) Coil the cables neatly; secure them with wires. Lubricate cables in accordance with the current lubrication order and label them for future use.

**11.5. Piledriver Conversion**

*a. General.* When using the crane-shovel as a piledriver, the following equipment and attachments are required: Crane boom, pile hoist cable, pile hammer cable, catwalk, piledriver guides, piledriver hammer, and leads.

*b. Installation.*

- (1) Install the crane boom (para 11).
- (2) Reeve the boom cables(para 11).
- (3) Install the piledriver as follows:
  - (a) Align the lead assembly with the boom end (fig. 9.11.1).
  - (b) Install the piledriver leads and adapters.
  - (c) Refer to figure 9.11.1 and install the

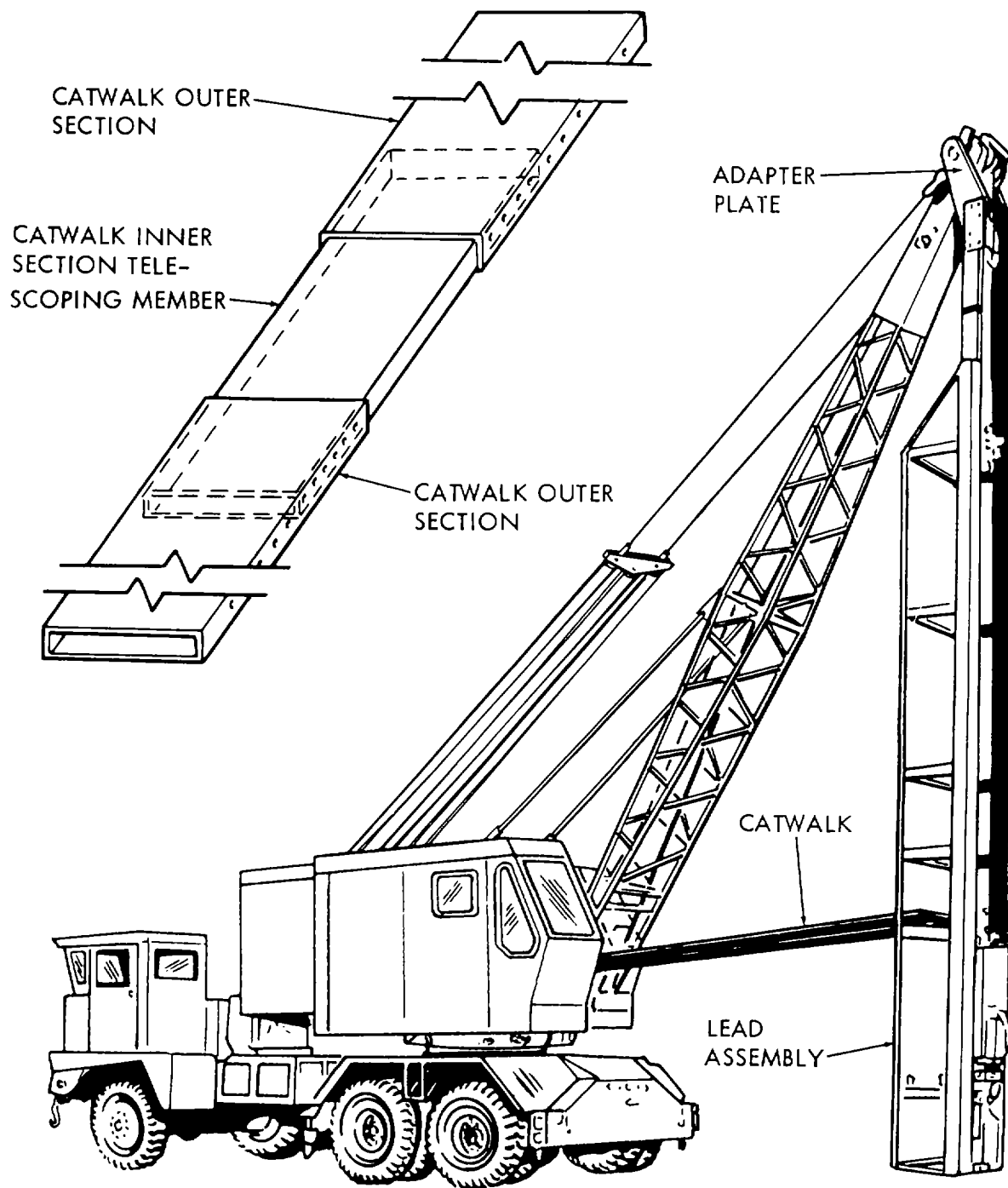

ME 3810-227-15/9.11.1 C5

Figure 9.11.1. Piledriver lead and adapter installation.



catwalk to the foot of the boom and the leads; adjust the catwalk so the leads are vertical, and bolt the catwalk sections together.

Figure 9.11.1 is added:

*c. Reeving the Piledriver.*

(1) *Reeving the piledriver hammer cable.*

(a) Install the cable in the drum socket in the left cable drum (fig. 9.12), and secure with the cable wedge.

(b) Lead the cable from the bottom of the drum out over the left boom point sheave.

Figure 9.12 is added:

(2) *Reeving the piledriver hoist cable.*

(a) Secure the cable to the right drum with the cable wedge.

(b) Lead the cable from the bottom of the drum out over the right boom point sheave.

(c) Install a thimble and the cable through the hook and secure with three cable clamps.

(d) Back the crane-shovel slowly toward the piledriver leads, at the same time hoisting the boom until the leads are vertical.

(e) Raise the boom until the bottom of the leads clear the hammer and position the leads over the hammer guides.

(f) Secure the left cable to the eye (fig. 9.12) on the hammer with the cable wedge, pin, and cotter pins, and raise the hammer into the leads. Swing the boom into position over the pile cap. Lower the hammer and secure the pile cap to the hammer with the wire rope sling. Raise the hammer and lift the cap into

the leads.

(g) Install the catwalk to the foot of the boom and the leads; adjust the catwalk so the leads are vertical, and bolt the catwalk sections together.

*d. Removing the Piledriver.*

(1) Lower the hammer enough to allow slack in the wire rope sling. Remove the sling and move the piledriver clear of the cap.

(2) Remove the bolts and nuts securing the catwalk sections. Raise the boom enough to clear the hammer and lower the hammer to the ground. Remove the cable from the hammer.

(3) Remove the bolts securing the catwalk to the leads and the boom, and lower the catwalk to the ground.

(4) Lower the leads to the ground and slow drive the carrier forward. At the same time, lower the beam to the wood blocks.

(5) Remove the piledriver lead adapters and leads. Secure the pile lead adapters to the leads.

*e. Unreeving the Piledriver.*

(1) Unreeve the pile hammer cable by reversing the reeving procedure.

(2) Unreeve the pile hoist cable by reversing the reeving procedure.

(3) Remove the crane boom (para 11).

*Page 140.* In figure 117, lower left corner, "Adjustment Clearance 0.047 inch" is deleted.

*Page 140.* In figure 118A, lower right corner, "Adjustment Clearance 0.047 inch" is deleted.

*Page 141.* Paragraph 199f is rescinded.

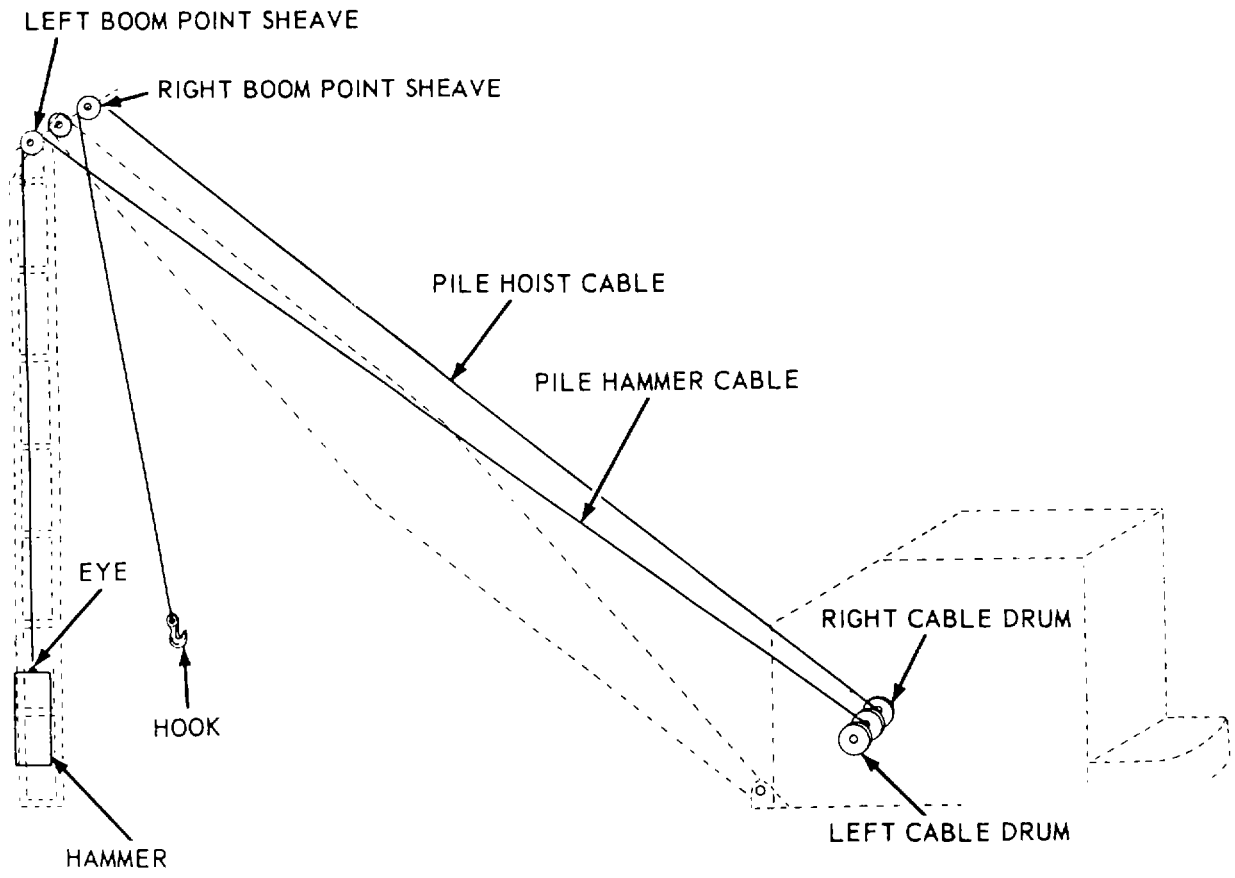

ME 3810-227-15/9.12 C5

Figure 9.12. Piledriver reeving diagram.

By Order of the Secretary of the Army:

CREIGHTON W. ABRAMS  
*General, United States Army*  
*Chief of Staff*

Official:

VERNE L. BOWERS  
*Major General, United States Army*  
*The Adjutant General*

Distribution:

To be distributed in accordance with DA Form 12-25B (qty rqr block No. 361), Operator requirements for Crane, Shovel, wheel or truck mounted, 20 Ton.

Change }  
No. 4 }

HEADQUARTERS  
DEPARTMENT OF THE ARMY  
Washington, D.C., 7 July 1972

**Operator's, Organizational, Direct Support, General Support, and Depot  
Maintenance Manual**

**CRANE-SHOVEL, BASIC UNIT, TRUCK MOUNTED: 20 TON  
3/4 CU. YD., GASOLINE ENGINE, 6x6 (AMERICAN  
HOIST AND DERRICK MODELS) MODEL 2360 (NON-  
WINTERIZED) FSN 3810-989-0505 MODEL W2360  
(WINTERIZED) FSN 3810-989-0506**

TM 5-3810-227-15, 10 December 1964, is changed as follows:

Page 3. Appendix III title is changed as follows:

**APPENDIX III. BASIC ISSUE ITEM LIST AND  
ITEMS TROOP INSTALLED or AUTHORIZED**

Page 354. Appendix III is superseded as follows:

**APPENDIX B  
BASIC ISSUE ITEM LIST AND ITEMS  
TROOP INSTALLED OR AUTHORIZED**

**Section I. INTRODUCTION**

**1. Scope**

This appendix lists basic issue items, items troop installed or authorized which accompany the Crane-Shovel, and required by the crew/operator for operation, installation, or operator's maintenance.

**2. General**

This basic issue items, items troop installed or authorized list is divided into the following sections:

*a. Basic Issue Items List-Section II. "Not Applicable".*

*b. Items Troop Installed or Authorized List-Section III. A list, in alphabetical sequence of items which at the discretion of the unit commander may accompany the end item, but are NOT subject to be turned in with the end item.*

**3. Explanation of Columns**

The following provides an explanation of columns in the tabular list of Basic Issue Items List, Section II, and Items Troop Installed or Authorized, Section III.

*a. Source, Maintenance, and Recoverability Code(s) (SMR):*

**\*This change supersedes C 3, 15 July 1968.**

(1) *Source code.* indicates the source for the listed item. Source code is:

<i>Code</i>	<i>Explanation</i>
P	Repair parts. Special tools and test equipment supplied from GSA/DSA or Army supply system and authorized for use at indicated maintenance levels.

(2) Maintenance code, indicates the lowest level of maintenance authorized to install the listed item. The maintenance level code is:

<i>Code</i>	<i>Explanation</i>
C	Crew/Operator

(3) Recoverability code, indicates whether unserviceable items should be returned for recover or salvage. Items not coded are non-recoverable. Recoverability codes are:

<i>Code</i>	<i>Explanation</i>
R	Applied to repair parts (assemblies and components), special tools and test equipment which are considered economically repairable at direct and general support maintenance levels.
S	Repair parts, special tools, test equipment and assemblies which are economically repairable at DSU and GSU activities and which normally are

furnished by supply on an exchange basis.

b. *Federal Stock Number.* This column indicates the Federal stock number assigned to the item and will be used for requisitioning purposes.

c. *Description.* This column indicates the Federal item name and an additional description of the item required.

d. *Unit of measure (U/M).* A two character alphabetic abbreviation indicating the amount of quantity of the item upon which the allowances are based e.g., ft, ea, pr, etc.

e. *Quantity Furnished With Equipment (BIIL only).* This column indicates the quantity of an item furnished with the equipment.

f. *Quantity Authorized (Items Installed or Authorized Only).* This column indicates the quantity of the item authorized to be used with the equipment.

g. *Illustration (BIIL only).* This column is divided as follows:

(1) *Figure Number.* Indicates the figure number of the illustration in which the item is shown.

(2) *Item Number.* Indicates the callout number used to reference the item in the illustration.

**Section III. ITEMS TROOP INSTALLED OR AUTHORIZED LIST**

(1) SMR code	(2) Federal stock number	(3) Description  Ref No & Mfr code	(4) Unit of meas  Usable on code	(5) Qty auth
PC	7520-559-1618	CASE, MAINTENANCE AND OPERATIONAL MANUAL	EA	1
PC	2590-045-9611	CASE, RIFLE	EA	1
PC	4210-555-8837	EXTINGUISHER, FIRE	EA	1

By the Order of the Secretary of the Army

BRUCE PALMER, JR.  
General, U.S. Army  
Acting Chief of Staff

Official:  
VERNE L. BOWERS.  
Major General, United States Army  
The Adjutant General

Distribution:  
To be distributed in accordance with DA Form 12-25B, (qty rqr block No. 362) Organizational maintenance requirements for Crane Shovel Truck MTD: 20 Ton.

Change }  
No. 2 }

HEADQUARTERS  
DEPARTMENT OF THE ARMY  
Washington, D.C., 31 January 1968

**Organizational, DS, GS, and Depot Maintenance Manual**

**CRANE-SHOVEL BASIC UNIT, TRUCK MOUNTED: 20 TON,  
3/4 CU. YD., GASOLINE ENGINE, 6x6 (AMERICAN HOIST  
AND DERRICK MODELS)**

**MODEL 2360 (NON-WINTERIZED) FSN 3810-989-0505**

**MODEL W2360 (WINTERIZED) FSN 3810-989-0506**

TM 5-3810-227-15, 10 December 1964, is changed as follows:

*Page 5.* Subparagraph 1*d* is superseded as follows:

*d.* Report of errors, omissions, and recommendations for improving this manual by the individual user is encouraged. Reports should be submitted on DA

Form 2028 (Recommended Changes to DA Publications) and forwarded direct to Commanding General, U.S. Army Mobility Equipment Command, ATTN: AMSME-MPP, 4300 Goodfellow Blvd., St. Louis, Mo., 63120.

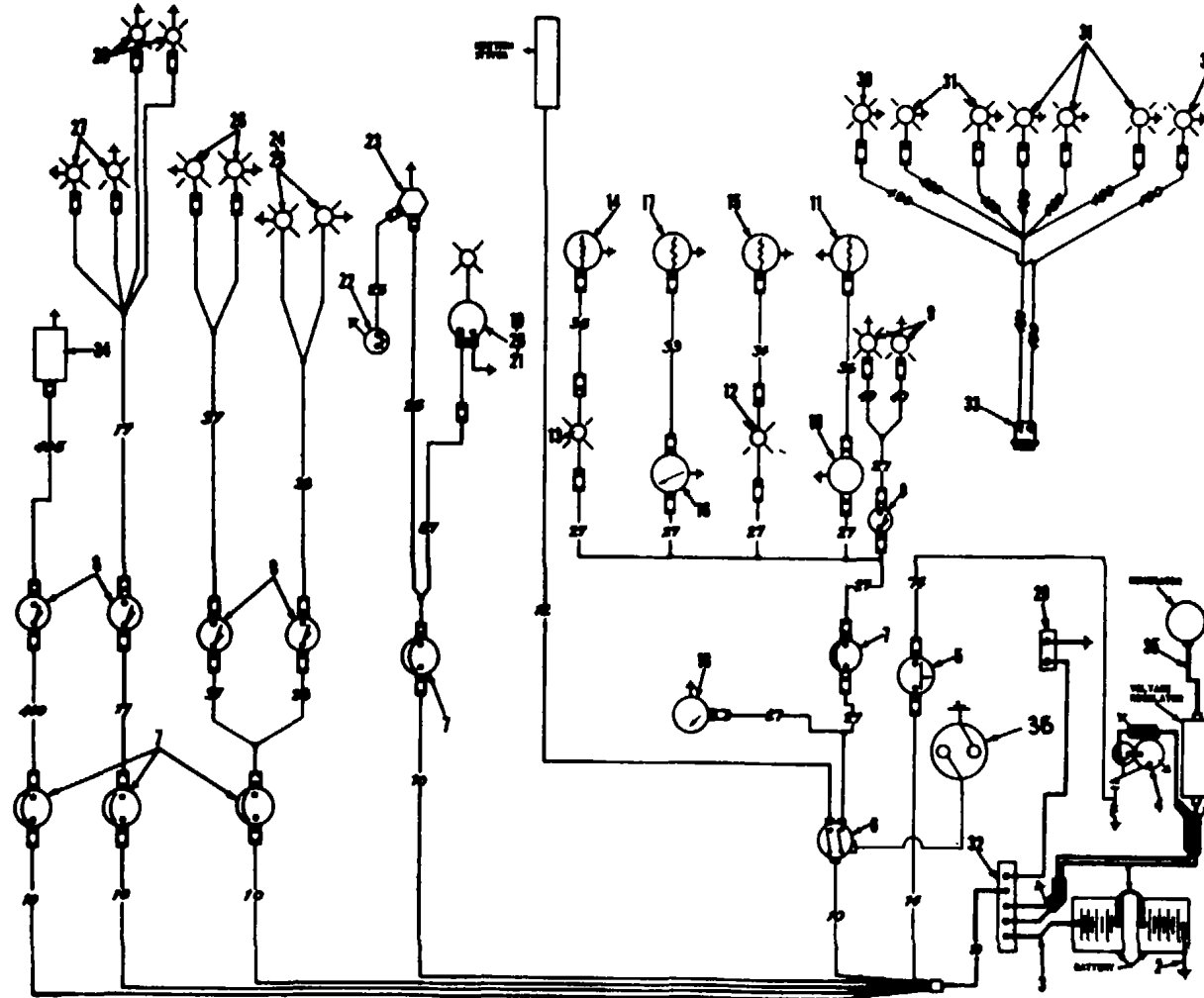

1. BATTERY CABLE (JUMPER)
2. BATTERY CABLE (GROUND)
3. BATTERY CABLE (POSITIVE)
4. STARTER MOTOR
5. STARTER SWITCH
6. IGNITION SWITCH
7. CIRCUIT BREAKER
8. TOGGLE SWITCH
9. DASH LIGHT
10. PRESSURE INDICATOR (OIL)
11. PRESSURE TRANSMITTER (OIL)
12. INDICATOR LIGHT (LOW-OIL)
13. INDICATOR LIGHT (HI-TEMP)
14. TEMPERATURE WARNING SWITCH
15. LOW OIL PRESSURE SENDING UNIT
16. TEMPERATURE INDICATOR
17. TEMPERATURE SENDING UNIT
18. BATTERY-GENERATOR INDICATOR
19. PISTOL GRIP AND REEL
20. PISTOL GRIP HOLDER
21. TROUBLE LAMP
22. HORN SWITCH
23. HORN
24. CAB LIGHT ADAPTER
25. CAB LIGHT
26. SKIRT FLOODLIGHT
27. TOP FLOODLIGHT (RIGHT)
28. TOP FLOODLIGHT (LEFT)
29. SLAVE RECEPTACLE
30. BLACK OUT CLEARANCE LIGHT
31. SERVICE MARKER
32. BUS BAR
33. WIRE ASSEMBLY
34. HEATER
35. CABLE (GENERATOR)
36. HOURMETER

NOTE: NUMBERS ON WIRES ARE  
LINE IDENTIFICATION NUMBERS.

B. - Crane wiring diagram

Figure 3 -Continued

Page 28. Subparagraph s.1 is added after subparagraph s.

s.1. *Hourmeter* (B, fig. 14). The hourmeter is located

in the center of the instrument panel, directly, below the starter button. The hourmeter records the elapsed time that the engine is run in hours and tenths of hours.



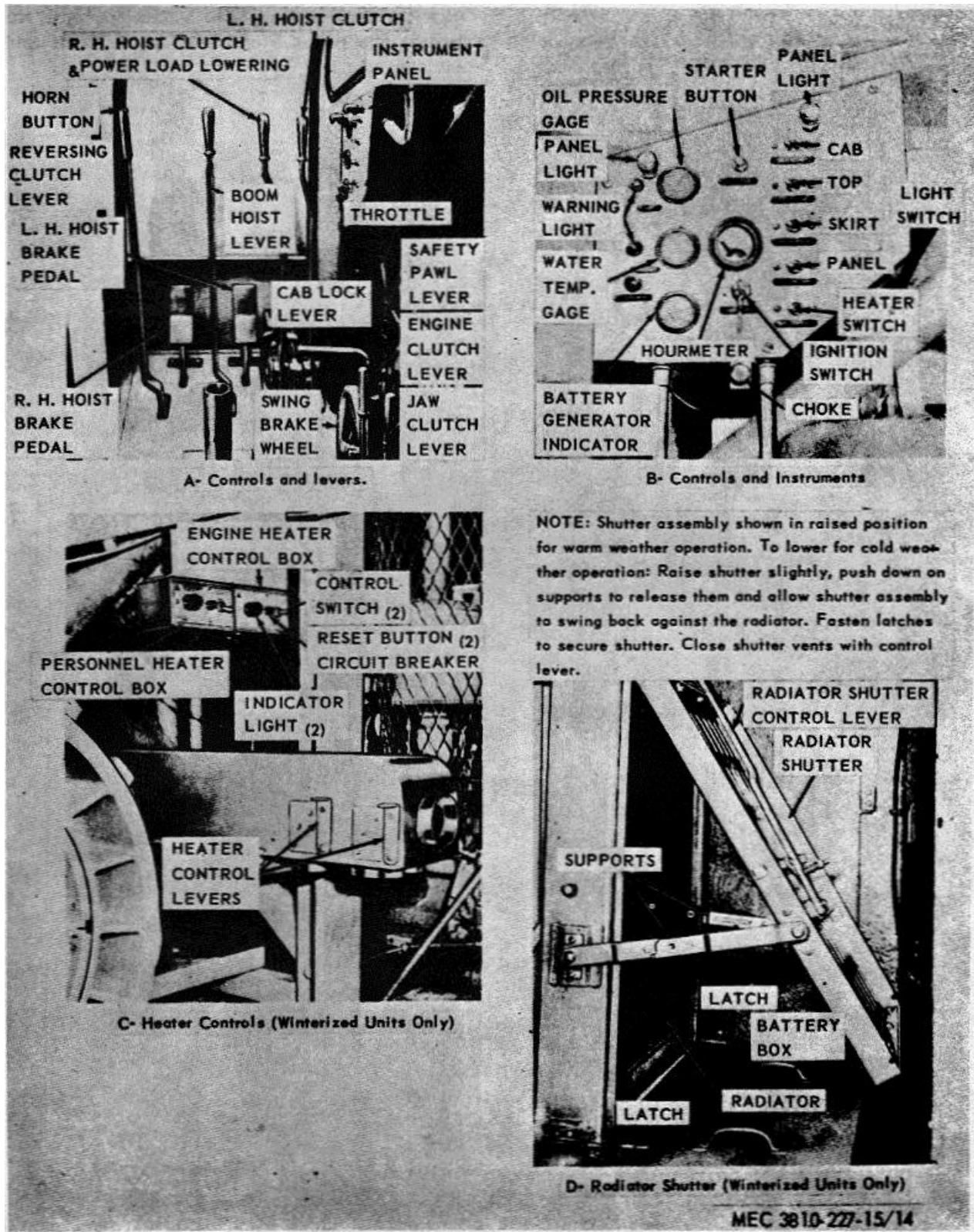

Figure 14. Crane controls and instruments

Page 110. Figure 72 is superseded as follows:

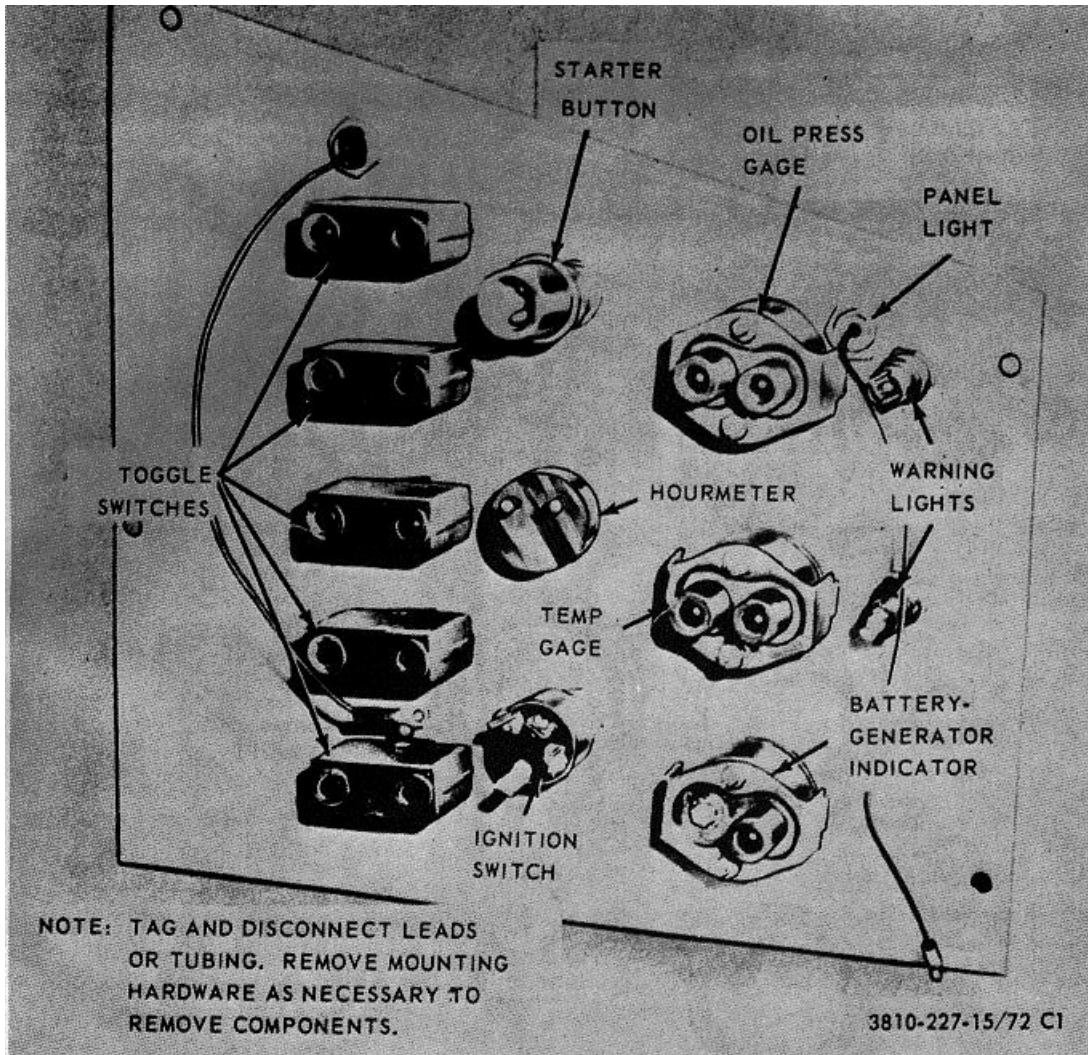

Figure 72. Instrument panel and components, removal and installation.

Page 204. Figure 184 is superseded as follows:

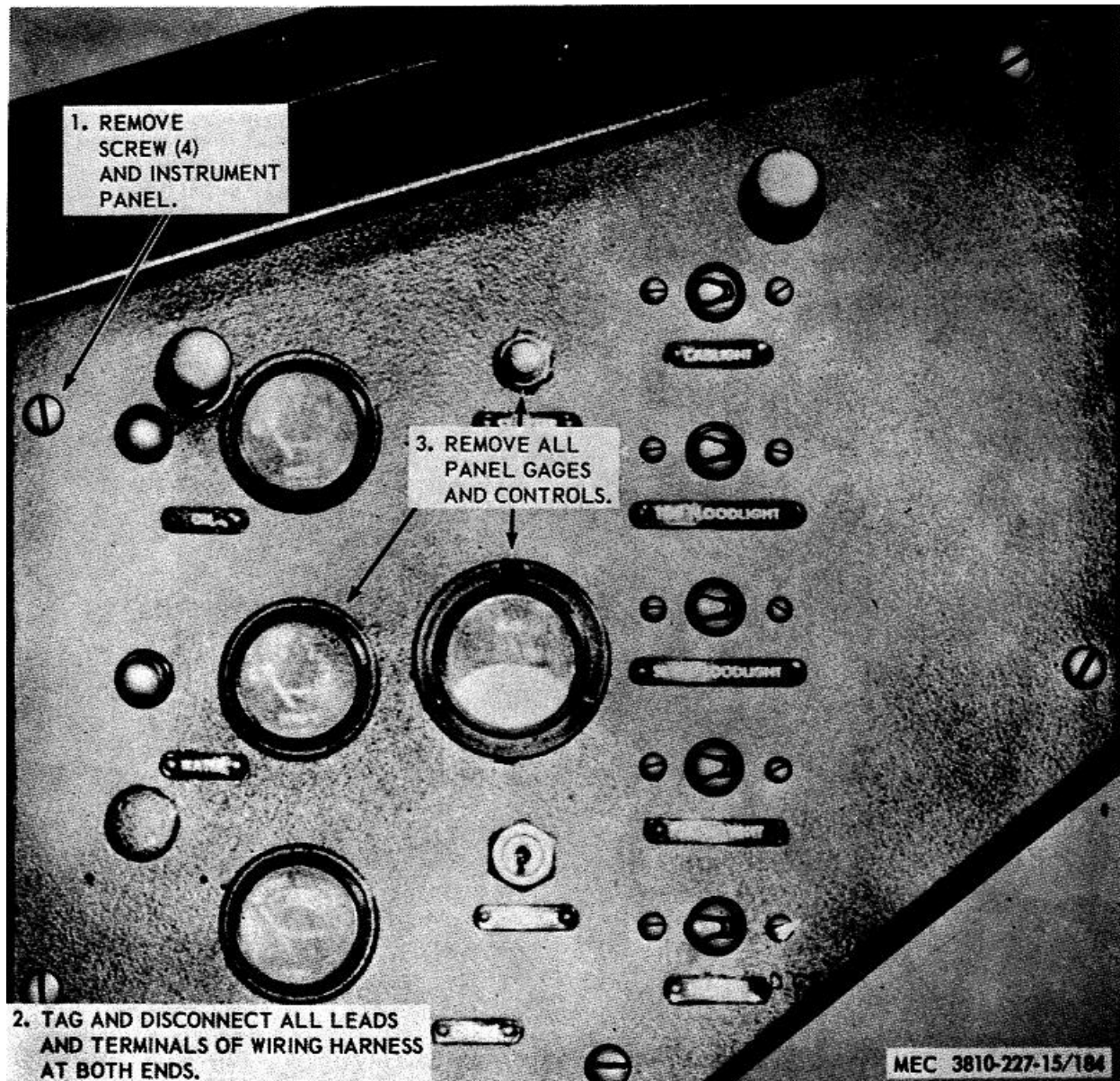

Figure 184. Crane instrument panel and wiring harness, removal and installation.

By Order of the Secretary of the Army:

HAROLD K. JOHNSON  
*General, United States Army*  
*Chief of Staff*

Official: \_\_\_\_\_

KENNETH G. WICKHAM  
*Major General, United States Army*  
*The Adjutant General.*

Distribution:

Active Army:

USASA (2)	Gen Dep (10)
ACSI (1)	Engr Dep (19)
DCSLOG (1)	Army Dep (2) except
CNGB (1)	TOAD (3)
TSG (1)	EAMTMTS (2)
C of Engrs (3)	WAMTMTS (2)
ACSC-E (1)	MOTBA (1)
Dir of Trans (1)	MOTBY ( 1)
C of Spt S (1)	MOTKI ( 1 )
USAMB (1)	MOTSU (1)
USAIB (2)	Div Engr (2)
USARADB (2 )	Engr Dist (2)
USAAESWBD (2)	Engr Cen (5)
USAAVNTBD (2)	Engr FLDMS (2)
USA Arty Bd (2)	Ft Knox FLDMS (10)
USA Armor Bd (2)	AMS (3)
USCONARC (3)	MAAG (1)
OS Maj Comd (5) except	JBUSMC (1)
USARJ (1)	USARMA (1)
USASETAF (2)	USARMIS (1)
USAMC (1)	USACOMZEUR (2)
USAMECOM (46)	Fld Comd, DASA (8)
USACDCEC (10)	USAREUR Engr Proc Cen (2)
MDW (1)	USAREUR Engr Sup Con Agvy (10)
Armies (2)	USA Mbl Equip R&D Cen (3)
Corps (2)	Units org under fol TOE:
USAC (1)	5-48 (2)
Div (2)	5-237 (5)
Engr Bde (1)	5-262 (5)
USMA (2)	5-267 (1)
Svc Colleges (2)	5-278 (5)
Br Svc Sch (2)	5-279 (2)

NG: State AG (3).

USAR: Same as Active Army except allowance is one (1) copy for each unit.

For explanation of abbreviations used, see AR 320-50.

Change }  
 No. 1 }

HEADQUARTERS  
 DEPARTMENT OF THE ARMY  
 Washington, D.C., 14 May 1965

**Organizational, DS, GS, and Depot Maintenance Manual**

**CRANE-SHOVEL, BASIC UNIT, TRUCK MOUNTED: 20 TON, 3/4 CU. YD., GASOLINE ENGINE,  
 6X6 (AMERICAN HOIST AND DERRICK MODELS) MODEL 2360 (NON-WINTERIZED)  
 FSN 3810-989-0505 MODEL W2360 (WINTERIZED) FSN 3810-989-0506**

TM 5810-227-15, 10 December 1984, is changed as follows:

Page 5, paragraph 1.

d. Superseded) The direct reporting by the individual user, of errors, omissions, and recommendations for improving this manual is authorized and encouraged. DA Form 2028 (Recommend Changes to DA Publication) will be used for reporting these improvements. This form will be completed in triplicate, using pencil, pen, or typewriter. The original and one copy will be forwarded direct to: Commanding General, U.S. Army Mobility Equipment Center, ATTN: SMOME-MMP, 4300 Goodfellow Boulevard, St. Louis, Mo., 68120.

Page 6, paragraph 4a.

- (7) (Superseded) *Power line caution plate.* There are two power line caution plates. One is located in the crane operator's cab to the right of the operator's controls of the crane. The other is located on the inside of the left door of the carrier operator's cab. They caution the operators to keep boom away from power lines.

Page 131, paragraph 183a(2). After (2) add:

**Warning**

**The accumulator (9, fig. 108) is a nonrepairable item. It is assembled under 600 lb psi and no attempts should be made in the field to dismantle this assembly.**

Page 164, paragraph 240c. After paragraph c add:

**Caution**

**The service air line shutoff valve on front of carrier must be left open to prevent building up of pressure in the brake system resulting in setting of the brakes.**

**Caution**

**The emergency air line shutoff valve on front end of carrier must be closed to prevent emptying the entire air system.**

**Caution**

**The emergency and service air line shutoff valves on the rear end of the carrier must always be closed.**

By Order of the Secretary of the Army:

HAROLD K. JOHNSON,  
General, United States Army,  
Chief of Staff

Official:

J. C. LAMBERT,  
Major General, United States Army,  
The Adjutant General

Distribution:

*Active Army:*

USASA (2)	Engr Bb (1)	JBUSMC (1)	
ACSI (1)	Svc Colleges (3)	Units organized under following	
DCSLOG (1)	Br Svc Sch (2) except	TOE's (2 each unless otherwise	
CNGB (1)	USAES (100)	indicated):	
TSG (1)	USMA (2)	5-5	3-500 EA, EB
CofEngrs (3)	Gen Dep (10)	5-6	7
CC-E (1)	Engr Dep (10J)	5-8	9-9
Dir of Trans (1)	Army Dep (2)	5-15	9-17
CofSptS (1)	USA Tml Comd (2)	5-16	9-47
USAMB (1)	Army To(1)	5-35	9-57
USA Arty Bd (2)	Div Zap (2)	5-36	9-87
USA Armor Bd (2)	Engr Dist (2)	5-48	9-167
USAIB (2)	USA Engr R&I lab (3)	5-54	9-227
USARADB (2)	USA Mbl Equip Om (1)	5-77	9-367
USAAESWBD (2)	Engr Con (3)	5-78	9-377
USAAVNTBD (2)	USAREUR Engr Proc Cen (3)	5-145	17
USCONARC (3)	USAREUR Engr gap Coo Agcy	5-146	29-16
OS Maj Comd (5) except	(10)	5-148	29-17
USASETAF (2)	Chicago Proc Ofc (10)	5-155	29-26
USARJ (10)	Engr Fld Maint Shops (2)	5-136	29-27
USAMOCOM (2)	USA Mbl Equip Cen (10)	5-177	29-36
USASMC (1)	Fld comd DASA (8)	5-237 (3)	29-37
MDW (1)	AMS (3)	5-262 (5)	37
Armies (2)	USACOMZEUR (2)	5-267 (1)	39-61
Corps (2)	USAC (1)	5278 (5)	55-117
Div (2)	MAAG (1)	5-279	55-458

NG: State AG (3).

USAR: Same as Active Army except allowance is one (1) copy for each unit  
For explanation of abbreviations used, see AR 320-50.

**TAGO 1683A**



**ORGANIZATIONAL, DS, GS, AND DEPOT MAINTENANCE MANUAL**

**CRANE-SHOVEL BASIC UNIT, TRUCK MOUNTED: 20 TON, 3/4 CU. YD.,**

**GASOLINE ENGINE, 6 x 6 (AMERICAN HOIST AND DERRICK MODELS)**

**MODEL 2360 (NON-WINTERIZED) FSN 3810-989-0505**

**MODEL W2360 (WINTERIZED) FSN 3810-989-0506**

		<i>Paragraph</i>	<i>Page</i>
CHAPTER	1. INTRODUCTION		
Section	I. General-----	1, 2	4
	II. Description and data-----	3-6	5
CHAPTER	2. INSTALLATION AND OPERATION INSTRUCTIONS		
Section	I. Service upon receipt of equipment-----	7-9	14
	II. Front end attachment, installation and removal-----	10-12	17
	III. Controls and instruments-----	13-15	22
	IV. Operation under usual conditions-----	16-21	31
	V. Operation under unusual conditions-----	22-27	35
	VI. Operation of auxiliary materiel used in conjunction with the carrier and crane-----	28-33	38
CHAPTER	3. OPERATOR AND CREW MAINTENANCE INSTRUCTIONS		
Section	I. Special tools and lubricants-----	34-36	41
	II. Preventive maintenance services-----	37-39	58
	III. Troubleshooting-----	40-78	67
	IV. Radio interference suppression-----	79-82	72
	V. Carrier engine fuel system-----	83-89	75
	VI. Crane engine fuel system-----	90-96	81
	VII. Carrier engine electrical system, controls and instruments-----	97-123	88
	VIII. Crane engine electrical system, controls and instruments-----	124-143	108
	IX. Carrier engine cooling system-----	144-151	112
	X. Crane engine cooling system-----	152-158	117
	XI. Carrier engine lubrication system-----	159-162	119
	XII. Crane engine lubrication system-----	163-166	121
	XIII. Carrier engine intake and exhaust system-----	167-171	122
	XIV. Crane engine intake and exhaust system-----	172-176	124
	XV. Carrier engine clutch assembly-----	177, 178	126
	XVI. Crane hydraulic system-----	179-183	129
	XVII. Crane clutch and brake assemblies controls and linkage-----	184-194	132
	XVIII. Primary drive assembly and gear guards-----	195-197	138
	XIX. Load roller assembly-----	198-200	139
	XX. Safety ratchet and jaw clutch assemblies-----	201, 202	141
	XXI. Crane boom, pulleys, and pulley bushings-----	203-207	143
	XXII. Crane cab assembly-----	208-211	146
	XXIII. Carrier steering assembly-----	212-222	149
	XXIV. Wheels, tires, and shock absorbers-----	223-230	154
	XXV. Carrier airbrake system-----	231-242	159
	XXVI. Propeller shafts and controls-----	243-246	166
	XXVII. Carrier frame-----	247-249	170
	XXVIII. Carrier cab and fenders-----	250-261	173
	XXIX. Carrier winterization equipment-----	262-272	177
	XXX. Crane winterization equipment-----	273-286	184



		<i>Paragraph</i>	<i>Page</i>
CHAPTER	4. DIRECT AND GENERAL SUPPORT, AND DEPOT MAINTENANCE INSTRUCTIONS.		
Section	I. Repair and replacement standards-----	287	189
	II. General servicing and repair instructions-----	288-295	193
	III. Removal and installation of major items-----	296-298	196
	IV. Crane engine carburetor assembly-----	299-302	198
	V. Crane engine governor assembly-----	303-306	199
	VI. Crane engine fuel tank-----	307-310	201
	VII. Crane engine generator assembly-----	311-314	204
	VIII. Crane instrument panel and wiring harness-----	316-318	204
	IX. Crane engine starter assembly-----	319-322	206
	X. Crane engine distributor assembly-----	323-326	206
	XI. Crane engine radiator assembly-----	327-330	207
	XII. Crane engine water pump assembly-----	331-334	209
	XIII. Crane engine clutch assembly-----	336-438	211
	XIV. Crane engine cylinder head assembly and valves-----	339-345	212
	XV. Crane engine oil pan and filler blocks-----	346-349	216
	XVI. Crane engine oil pump assembly-----	350-353	217
	XVII. Crane engine piston and connecting rod assemblies-----	354-357	218
	XVIII. Crane engine flywheel and flywheel housing-----	358-361	221
	XIX. Crane engine front mount and pulley assembly-----	362-365	222
	XX. Crane engine timing gear cover and timing gears-----	366-369	224
	XXI. Crane engine camshaft assembly-----	370-378	225
	XXII. Crane engine crankshaft assembly-----	374-377	226
	XXIII. Crane engine block-----	378-381	228
	XXIV. Carrier engine carburetor assembly-----	382-385	229
	XXV. Carrier engine speed governor assembly-----	386-389	231
	XXVI. Carrier engine generator assembly-----	390-393	232
	XXVII. Carrier engine starter assembly-----	394-397	233
	XXVIII. Carrier engine distributor assembly-----	398-401	233
	XXIX. Carrier engine accessory drive assembly-----	402-405	234
	XXX. Carrier engine radiator assembly-----	406-409	235
	XXXI. Carrier engine water pump assembly-----	410-413	236
	XXXII. Carrier engine oil filter base and oil cooler assembly-----	414-417	237
	XXXIII. Carrier engine rocker arm and push rods assembly-----	418-421	238
	XXXIV. Carrier engine cylinder head and valves-----	422-425	240
	XXXV. Carrier engine oil pan-----	426-429	241
	XXXVI. Carrier engine oil pump assembly-----	430-433	243
	XXXVII. Carrier engine connecting rod and piston assemblies-----	434-487	244
	XXXVIII. Carrier engine clutch housing-----	488-441	246
	XXXIX. Carrier engine clutch assembly-----	442-445	248
	XL. Carrier engine flywheel and flywheel housing-----	446-449	249
	XLI. Carrier engine vibration damper and pulley assembly-----	450-453	251
	XLII. Carrier engine timing gears-----	454-457	252
	XLIII. Carrier engine camshaft-----	458-461	254
	XLIV. Carrier engine crankshaft and main bearings-----	462-465	255
	XLV. Carrier engine block-----	466-469	256
	XLVI. Carrier transmission assembly-----	470-473	257
	XLVII. Carrier transfer case assembly-----	474-477	269
	XLVIII. Carrier air compressor assembly-----	478-481	273
	XLIX. Carrier front air brake chamber assembly-----	482-485	276
	L. Carrier rear air brake chamber assembly-----	486-489	276
	LI. Carrier moisture ejector valve assembly-----	490-493	278
	LII. Carrier air brake double check valve assembly-----	494-497	279
	LIII. Carrier handbrake-----	498-501	279
	LIV. Carrier front service brake assembly-----	502-505	282
	LV. Carrier rear service brake assembly-----	506-509	283
	LVI. Carrier treadle valve assembly-----	510-518	283
	LVII. Carrier air brake quick release valve-----	514-517	285
	LVIII. Carrier trailer brake valve-----	518-521	285

		<i>Paragraph</i>	<i>Page</i>
	LIX. Carrier air brake protection valve assembly-----	522-525	287
	LX. Carrier air brake relay assembly-----	526-529	288
	LXI. Carrier steering hydraulic pump assembly-----	530-533	288
	LXII. Carrier -steering hydraulic control valve assembly-----	534-537	289
	LXIII. Carrier steering hydraulic cylinder assembly-----	538-541	290
	LXIV. Carrier steering column and gear assembly-----	542-545	290
	LXV. Carrier steering knuckle and shaft assembly-----	546-549	294
	LXVI. Carrier front differential assembly-----	550-553	295
	LXVII. Carrier front spring assembly-----	554-557	296
	LXVIII. Torque rod assembly-----	558-561	297
	LXIX. Equalizing beam assembly-----	562-565	298
	LXX. Carrier rear, rear axle differential assemblies-----	566-569	299
	LXXI. Carrier engine and crane engine, liquid heater repair instructions-----	570-575	303
	LXXII. Carrier cab and crane cab, fresh air heater repair instructions-----	576-581	307
	LXXIII. Crane hydraulic master cylinder assemblies and clutch cylinder assemblies-----	582-588	308
	LXXIV. Crane hoist-drum shaft-----	589-592	310
	LXXV. Crane countershaft assembly-----	593-596	312
	LXXVI. Crane independent boom hoist shaft assembly-----	597-600	313
	LXXVII. Crane horizontal reversing shaft assembly-----	601-604	315
	LXXVIII. Crane vertical reversing shaft assembly-----	605-608	316
	LXXIX. Crane vertical owing shaft assembly-----	609-612	317
	LXXX. Crane auxiliary shaft assembly (power load lowering)-----	613-616	318
	LXXXI. Crane rotating frame base assembly-----	617-620	319
	LXXXII. Rotating frame ring gear-----	621-624	321
	LXXXIII. Crane gantry frame-----	625-628	322
CHAPTER	5. DEMOLITION, SHIPMENT AND LIMITED STORAGE		
Section	I. Demolition of the crane to prevent enemy use-----	629-633	323
	II. Shipment and limited storage-----	634-637	325
APPENDIX	I. REFERENCES-----		328
	II. MAINTENANCE ALLOCATION-----		330
	III. BASIC ISSUE ITEMS LIST AND MAINTENANCE AND OPERATING SUPPLIES-----		354

AGO 6819A

# CHAPTER 1

## INTRODUCTION

### Section I. GENERAL

#### 1. Scope

a. This manual is published for the use of the personnel to whom the American Hoist and Derrick Company Model 2360 (non-winterized) and Model W2360 (winterized) Crane-Shovel are issued. Chapters 1 through 3 provide information on the operation, preventive maintenance services, and organizational maintenance of the equipment, accessories, components, and attachments. Chapter 4 provides information for direct and general support and depot maintenance. Also included are descriptions of main units and their functions

in relationship to other components.

b. Appendix I contains a list of publications applicable to this manual. Appendix II contains the maintenance allocation chart. Appendix III contains the list of basic issue items and maintenance and operating supplies authorized the operator of this equipment. The Organizational Maintenance Repair Parts and Special Tools are listed in TM 5-3810-227-20P. The Direct and General Support and Depot Maintenance Repair Parts and Special Tools

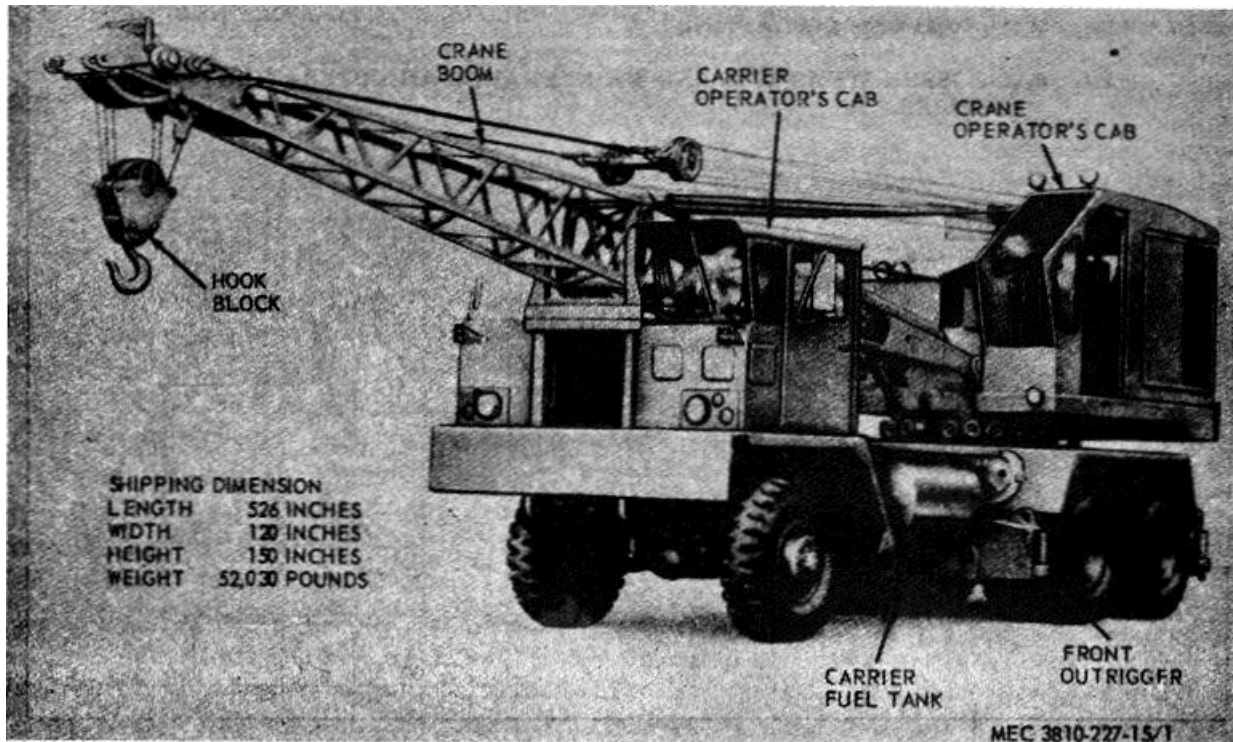

Figure 1. Crane-shovel, left, three-quarter front view and shipping dimensions.

AGO 6819A

are listed in TM 5-3810-227-35P. The levels of maintenance in all cases are governed by the maintenance allocation chart.

c. Numbers in parentheses on illustrations indicate quantity. Numbers preceding nomenclature callouts on illustrations indicate the preferred maintenance sequence.

d. The direct reporting by the individual user, of errors, omissions, and recommendations for improving this manual is authorized and encouraged. DA Form 2028 (Recommended Changes to DA Publications) will be used for reporting these improvements. This form will be completed in triplicate using pencil, pen, typewriter. The original and one copy will be forwarded direct to: Commanding Officer, U.S. Army Mobility Equipment Center, ATTN: SMOME-MMP, Post Office Drawer 58, St. Louis, Mo. 63166.

e. Report all equipment improvement recommendations as prescribed by TM 38-750.

## 2. Record and Report Forms

a. DA Form 2258 (Depreservation Guide of Engineer Equipment).

b. For other record and report forms applicable to the operator, crew, organizational, direct and general support, and depot maintenance, refer to TM 38-750.

### Note

**Applicable forms, excluding Standard Form 46 which is carried by the operator, shall be kept in a canvas bag mounted on the equipment.**

## Section II. DESCRIPTION AND DATA

### 3. Description

a. *Crane-Shovel.* The American Hoist and Derrick Company Model 2360 non-winterized and Model W2360 winterized Crane-Shovel (figs. 1 and 2) is a gasoline engine-driven, 3/4-cubic yard machine, truck mounted, and is designed for use with a crane boom. This crane-shovel is powered by a Continental Model BS-415, 6-cylinder, internal-combustion, gasoline engine. The crane, upon which are mounted the engine, upper machinery, and gantry, revolves around the center pin on rollers. In this manual, the terms left and right are used with respect to the operator's seat. "Front" is the end of the crane to which the boom is installed. "Rear" is the end of the crane which contains the engine and the counterweight. The crane cab is equipped with a heater. Winterized unit has an additional gasoline-fired heater that heats the engine and its components.

b. *Carrier.* The carrier is a heavy-duty, 6x6 American Hoist and Derrick Company Unit, and is powered by a Continental Model SS-749, six-cylinder, overhead-valve, internal-combustion engine. The carrier is equipped with power steering, air-brakes, five speed transmission, two-speed transfer case, and six-wheel drive. The carrier is equipped with two outriggers on each side to improve stability. The engine and the cab are mounted side-by-side on the front of the carrier. On

winterized units there are two heaters. The engine heater provides heat to the engine and its components, and the cab heater provides heat to the cab and the battery box defrosters.

### 4. Identification and Tabulated Data

The crane-shovel and carrier have twenty-six identification data and/or instruction plates.

a. Identification.

- (1) *Corps of Engineers carrier identification plates.* This plate is located to the left side of the carrier main frame behind the operator's cab. It contains the nomenclature for the carrier, make, model, and serial number, and also the make, model, and serial number of the engine.
- (2) *Transmission and transfer case shifting warning plate.* This plate is located to the right, on the inside of the carrier cab. It contains precautionary measures for proper operation.
- (3) *Transportation data instruction plate.* The transportation plate is mounted on the left side of the carrier main frame. It gives data on the length, height, width, and weight of the crane-shovel and carrier. It also shows

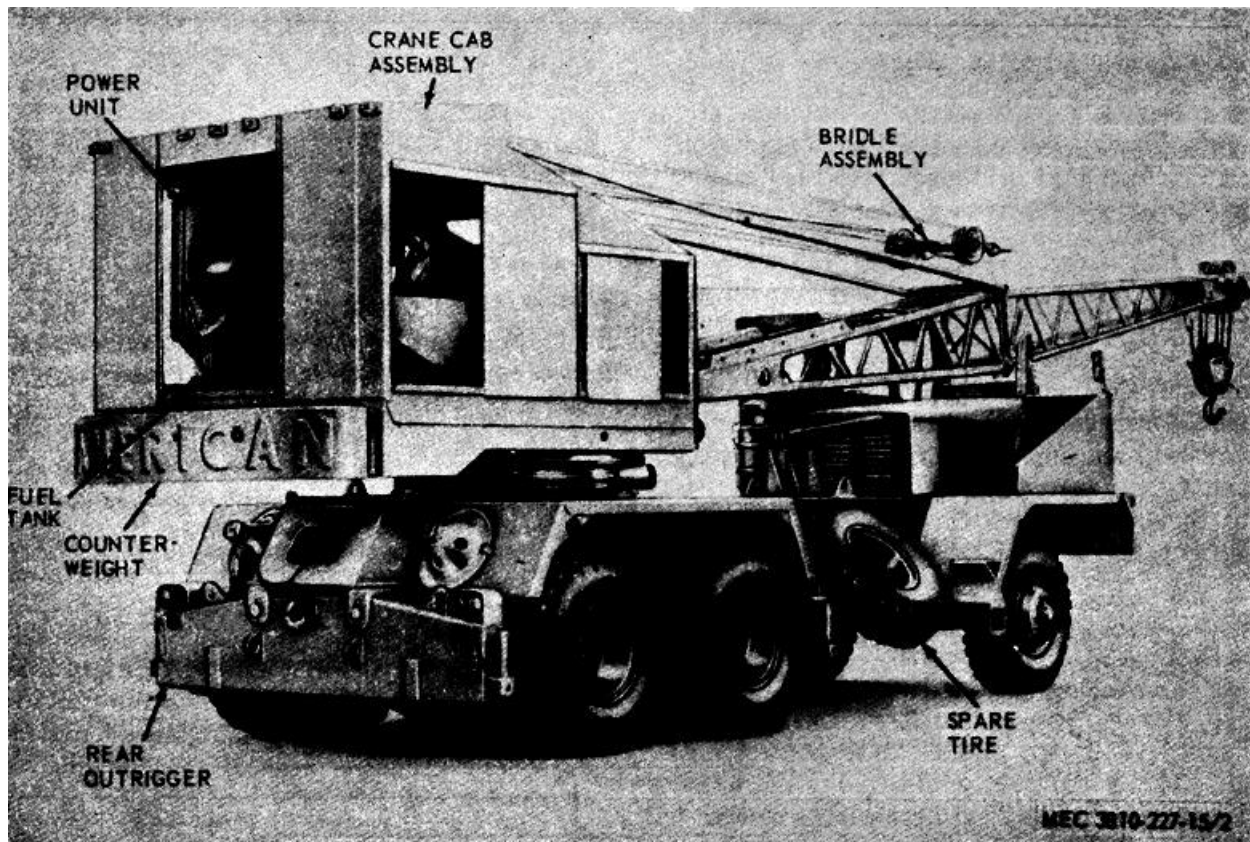

Figure 2. Crane-shovel, right, three-quarter rear view.

- the proper position of the crane-shovel lifting slings.
- (4) *Corps of Engineers crane identification plate.* The Corps of Engineers identification plate is located on the front of the revolving superstructure frame of the crane. It gives the crane nomenclature, Federal stock number, manufacturer, model, serial number, date of manufacture, contract number, and U.S.A. registration number. It also gives the make, model, and serial number of the crane engine.
  - (5) *Crane control lever instruction plate.* The crane control lever instruction plate is located inside the cab to the right of the operator's controls. It gives instruction on the use of levers, pedals, and other controls.
  - (6) *Crane lifting capacities, boom angle and height instruction plate.* The crane lifting capacities instruction plate is located in the operator's cab next to the instrument panel. It gives the data on the length of boom and radius, with and without outriggers and the distance in feet from center of rotation.
  - (7) *Power line caution plate.* The power line caution plate is located in the operator's cab to the right of the operator's controls of the crane. It cautions operator to keep boom away from power lines.
  - (8) *Brake caution plate.* The brake caution plate is located to the right, inside the operator's cab of the carrier. It gives instruction on the use of the brakes.
  - (9) *Corps of Engineers boom extension identification plate.* The Corps of Engineers identification plate is located on the left side of the boom extension assembly. It gives the nomenclature,

AGO 6819A

- Federal Stock Number, contract number, date of manufacture, and the size and type of unit with which the boom extension may be-used.
- (10) *Corps of Engineers 30 foot boom identification plate.* The Corps of Engineers identification plate is located on the left side of the boom near the lower end. It gives the nomenclature, Federal stock number, contract number, date of manufacture.
  - (11) *Boom caution plate.* The boom caution plate is located on the outside of the back of the carrier operator's cab. It gives instructions on supporting the boom with cables when traveling.
  - (12) *Transmission and transfer case shift plate.* The transfer shift plate is mounted on the dash of the carrier cab. It shows shifting position of the transfer case shift lever.
  - (13) *Front axle instruction plate.* The front axle instruction plate is located on instrument panel. It shows position of the declutch control.
  - (14) *Boom hoist jaw clutch instruction plate.* The boom hoist jaw clutch instruction plate is located in the crane operator's cab, behind and to the right of the operator's seat. It shows shifting position of the jaw clutch lever.
  - (15) *Engine clutch instruction plate.* The engine clutch instruction plate is located in the crane operator's cab behind, and to the right of, the operator's seat. It shows shifting position of the engine clutch lever.
  - (16) *Boom hoist ratchet (safety pawl) instruction plate.* The boom hoist ratchet (safety pawl) instruction plate is located in the crane operator's cab to the right of the operator's seat. It shows shifting position of the safety pawl (boom hoist ratchet) control lever.
  - (17) *Carrier data plate.* The carrier plate is located to the left side of the carrier main frame behind the operator's cab. It shows nominal carrier weight and dimensions for locating the center of gravity.
  - (18) *Crane (upper works) data plate.* The crane (upper works) data plate is located on the left side at the front of the revolving superstructure from of the crane. It shows nominal crane weight and dimensions for locating the center of gravity.
  - (19) *Counterweight data plate.* The counterweight data plate is located on the back of the counterweight at the rear of the crane. It shows nominal weight and dimensions for locating the center of gravity.
  - (20) *Inner boom data plate.* The inner boom data plate is located on the left side of the boom near the lower end. It shows nominal weight and dimensions for locating the center of gravity.
  - (21) *Outer boom data plate.* The outer boom data plate is located on the left side of the outer boom near the sheave point. It shows nominal weight of the outer boom and dimensions for locating the center of gravity.
  - (22) *Boom extension data plate.* The boom extension data plate is located on the left side of the boom extension near the midpoint. It shows nominal weight of the boom extension and dimensions for locating the center of gravity.
  - (23) *Rear outrigger beam data plate.* There are two rear outrigger beam data plates. One located on the outer end of each beam. They show nominal weight and dimensions for locating the center of gravity.
  - (24) *Forward outrigger beam data plate.* There are two forward outrigger beam data plates. One located on the outer end of each beam. They show nominal weight and dimensions for locating the center of gravity.
  - (25) *Rear outrigger box data plate.* The rear outrigger box data plate is located at the left on the back side of the out-

rigger box. It shows nominal weight and dimensions for locating the center of gravity.

- (26) *Forward outrigger box data plate.* The forward outrigger box data plate is located at the left on the front, or forward, side of the outrigger box. It shows nominal weight and dimensions for locating the center of gravity.

## 5. Differences in Models

This manual covers the American Hoist and Derrick Company Model 2360 non-winterized and Model W2360 Winterized Crane-Shovel mounted on the carrier.

## 6. Tabulated Data

### a. Carrier.

#### (1) General.

Manufacturer----- American Hoist and Derrick Co.  
Designed use----- Carrier for crane

#### (2) Engine.

Manufacturer----- Continental  
Model number----- SS 749  
Type ----- Gasoline  
Number of Cylinders----- 6  
Firing Order ----- 1-5-3-6-2-4  
Spark plug gap (Standard plug)----- 0.025 in. (inches)  
Spark plug gap (Resistor plug)----- 0.035 in. (inches)  
Governed speed ----- 2800 rpm (revolutions per minute)  
Horsepower----- 232 hp. (horsepower) at 2800 rpm  
Cycle----- 4  
Cooling----- Liquid  
Fan belt deflection----- 1/4 to 3/4 in.  
Bore----- 5-3/8 in. (inches)  
Stroke ----- 5 1/2 in.  
Total displacement ----- 749 cu. in. (cubic inch)  
Rotation at flywheel end----- Counterclockwise  
Clutch adjustment ----- Adjust to contact

#### (3) Starting motor.

Make----- Delco-Remy  
Model number----- 1113143  
Volts ----- 24

#### (4) Battery-charging generator.

Make----- Delco-Remy  
Model----- 1117478  
Volts ----- 24

#### (5) Generator regulator.

Make----- Delco-Remy  
Model----- 1118558  
Volts ----- 24

#### (6) Distributor.

Make----- Delco-Remy  
Model----- 1111656  
Volts ----- 24

#### (7) Air cleaner.

Make----- Donaldson  
Model----- KAXOO-0379  
Type ----- Oil Bath

#### (8) Lubrication oil filter.

Make----- AC Spark Plug Division  
Model----- 6664398  
Cartridge----- 60361

#### (9) Battery.

Make----- Gould  
Type ----- Dry charge (MS35000-3)  
Volts ----- 12

#### (10) Personnel heater.

Manufacturer----- Perfection  
Model----- Ord No. 8682958  
Volts ----- 24  
Type of Control----- Manual

#### (11) Capacities.

Engine crankcase----- 22 qt (quarts)  
Engine oil filters (2)----- 2 qt ea (each)  
Engine air cleaner ----- 4 qt  
Fuel tank----- 100 gal (gallons)  
Radiator----- 46 qt  
Transmission ----- 12 qt (8 qt front, 4 qt rear)  
Transfer case----- 2 1/2 qt  
Front axle----- 7 qt  
Rear axle (2)----- 12 qt ea

### b. Crane.

#### (1) General.

Manufacturer----- American Hoist and Derrick Co.  
Designed use----- Crane and shovel

#### (2) Engine.

Manufacturer----- Continental Motors Corp.  
Model Number----- BS 415  
Type ----- Gasoline  
Serial numbers----- 20-001 through 20-500  
Number of Cylinders----- 6  
Firing order----- 1-5-3-6-2-4  
Spark plug gap (Standard plug)----- 0.025 in.  
Spark plug gap (Resistor plug)----- 0.035 in.  
Governed speed ----- 1800 rpm  
Horsepower----- 78 at 1,800 rpm  
Cooling----- Liquid cooled  
Fan belt deflection----- 1/2 to 3/4 in.  
Bore----- 4 1/4 inches  
Stroke ----- 4 7/8 inches  
Clutch Adjustment----- Adjust to contact

#### (3) Starting motor.

Make----- Delco-Remy  
Model----- 1113116  
Volts ----- 4

(4) *Battery-charging generator.*

Make..... Autolite  
Model..... GKG-480 1-ST  
Volts..... 24

(5) *Generator regulator.*

Make..... Autolite  
Model..... VBU-4001-U-UT  
Volts..... 24

(6) *Distributor.*

Make..... Delco-Remy  
Model..... 1111675  
Volts..... 24

(7) *Air cleaner.*

Make..... Donaldson  
Model..... KAXOO-0377  
Type..... Oil Bath

(8) *Lubrication oil filter.*

Make..... Fram  
Model..... F31PL  
Cartridge..... U501L-404

(9) *Battery.*

Make..... Gould  
Type..... Dry Charge (MS 35000-3)  
Volts..... 12

(10) *Capacities.*

Engine Crankcase..... 12 qt  
Oil Filters (2)..... 1 qt ea  
Air Cleaner..... 2 qt  
Fuel tank..... 50 gal  
Radiator..... 28 qt  
Main drive chain case..... 2 qt  
Hydraulic control cylinders..... 2 qt ea  
Air compressor (winterized unit only)..... 1/4 qt

(11) *Personnel heater.*

Make..... Perfection  
Model..... Ord. No. 8682953  
Volts..... 24

*c. Adjustments.*

(1) *Carrier valve-adjustment.*

Tappet clearance:  
Intake.....0.020 in.  
Exhaust.....0.024 in.

(2) *Crane valve adjustment.*

Tappet clearance:  
Intake.....0.017 in.  
Exhaust..... 0.022 In.

(3) *Distributor point adjustment.*

Points (Carrier and crane engine).....0.020 in.

(4) *Spark plug adjustment.*

Carrier engine (Standard plug).....0.025 in.  
Carrier engine (Resistor plug).....0.085 in.  
Crane engine (Standard plug).....0.025 in.  
Crane engine (Resistor plug).....0.085 in.

(5) *Generator regulator adjustment.*

(a) *Mechanical adjustments.*

Cutout relay air gap..... 0.048 in.  
Contact points..... 0.035 in.  
Voltage regulator airgap..... 0.084 in.

(b) *Electrical adjustments.*

Cutout relay closing voltage..... 26 volts  
Voltage regulator opening voltage..... 29.2 volts  
Current regulator maximum amperage  
40 amp (amperes)

*d. Nut and Bolt Torque Data.* The nut and bolt torque wrench tension is a general guide to indicate foot-pounds of torque to be applied to various sizes of common hardware.

<i>Diameter in inches</i>	<i>Foot-pounds</i>
3/8.....	60-70
7/16.....	75-85
1/2.....	95-105
9/16.....	125-135
5/8.....	150-160
11/16.....	195-200
3/4.....	210-230
13/16.....	230-250
7/8.....	245-275
1.....	285-315
1 1/8.....	325-350

*e. Wiring Diagrams.* See figure 3.

*f. Dimensions.*

Overall length (carrier with counterweight to rear)..... 299.5 in.  
Overall width (carrier)..... 120 in.  
Overall height (carrier)..... 150 in.  
Carrier frame height (top of frame to ground)..... 57 3/4 in.  
Carrier wheel base..... 184 in.  
Carrier turning radius..... 450 in.  
Crane-shovel overall length (less boom)..... 342 in.  
Crane-shovel overall length (w/30 ft. boom).. 526 in.  
Shipping cubage (carrier and crane with counterweight to rear)..... 3562.5 cubic feet  
Shipping cubage (30 ft boom)..... 285 cubic feet  
Shipping cubage (10 ft, boom insert).... 90 cubic feet  
Total crane-shovel gross weight..... 52,030 pounds

*g. Cable Specification.*

Crane boom, standard 30 foot:  
Boom hoist cable..... 1/2 in. dia. (diameter),  
6x9 right regular lay,  
240 ft lg (long)  
Primary hoist cable..... 1/2 in. dia., 6x19 right  
regular lay, 360 ft lg  
Secondary hoist cable..... 1/2 in., dia, 6x19 left  
regular lay, 360 ft lg

**Note.**

**For each additional 10 feet of boom, add 10 feet to hoist and drag cable lengths. Add pendant cables as required for various lengths of extensions.**



*h. Crane-Lifting Capacities.* Crane lifting capacities are listed in table 1. Eighty-five percent of tipping rated loads shown are gross hook loads measured from the center of rotation and include the weight of the bucket and

any other external auxiliary lifting means. Ratings are based on crane standing on a firm and level supporting surface. Rated loads are in pounds over either side or rear.

**Table 1. Crane Lifting Capacitor**

Maximum capacity of crane without outriggers							
Radius	Boom length		(Use outriggers when boom length exceeds 40 feet)				
	30 ft	40 ft					
10	24,000 lb	-----					
12	-----	17,700 lb					
15	14,800 lb	13,000 lb					
20	9,700 lb	8,000 lb					
25	7,100 lb	6,800 lb					
30	5,500 lb	4,500 lb					
35	-----	3,700 lb					
40	-----	3,200 lb					

  

Maximum capacity of crane with outriggers (Use outriggers when boom length exceeds 40 feet)							
Radius	30 ft	40 ft	50 ft	60 ft	70 ft	80 ft	90 ft
10	40,000 lb						
12	-----	31,000 lb					
15	27,700 lb	26,300 lb	25,000 lb	24,000 lb			
20	20,000 lb	19,000 lb	18,000 lb	17,000 lb	16,000 lb		
25	15,500 lb	14,700 lb	13,900 lb	13,000 lb	12,200 lb	11,500 lb	10,700 lb
30	12,000 lb	11,600 lb	11,000 lb	10,200 lb	9,500 lb	9,000 lb	8,500 lb
35	-----	9,100 lb	8,700 lb	8,200 lb	7,700 lb	7,300 lb	6,800 lb
40	-----	7,400 lb	7,000 lb	6,700 lb	6,300 lb	5,900 lb	5,500 lb
45	-----	-----	5,800 lb	5,500 lb	5,100 lb	4,800 lb	4,500 lb
50	-----	-----	4,700 lb	4,500 lb	4,200 lb	4,000 lb	3,800 lb

Reduce main book capacity 800 pounds when jib is added. Use jib only on 50, 60, or 70 foot booms. Jib rating-3800 pounds up to 50 foot radius.

- |   |                                 |                                |
|---|---------------------------------|--------------------------------|
| 1 Turn signal switch                      | 23 Receptacle assembly          | 46 Bus bar                     |
| 2 Turn signal flasher                     | 24 Dimmer switch                | 47 Wire assembly               |
| 3 Warning light flasher                   | 25 Turn light indicator (right) | 48 Connector                   |
| 4 'Y' Type connector                      | 26 Turn light indicator (left)  | 49 Cable, generator            |
| 5 Selector switch                         | 27 Panel light (high beams)     | 50 Starter button              |
| 6 Vehicular light switch                  | 28 Buzzer                       | 51 Ignition switch             |
| 7 Stop switch                             | 29 Warning switch (Hi-temp)     | 52 Circuit breaker             |
| 8 Blackout clearance light                | 30 Pressure switch (Low-oil)    | 53 Battery-generator indicator |
| 9 Turn light (left front)                 | 31 Pressure transmitter         | 54 Horn                        |
| 10 Service headlamp                       | 32 Transmitter (water-temp)     | 55 Trouble lamp                |
| 11 Blackout marker and service park light | 33 Fuel sending unit            | 56 Pistol grip and red holder  |
| 12 Blackout headlamp                      | 34 Switch (low air)             | 57 Pistol grip and red         |
| 13 Clearance lamp                         | 35 Indicator light (Hi-temp)    | 58 Horn button                 |
| 14 Wire assembly                          | 36 Indicator light (Low-oil)    | 59 Wire assembly               |
| 15 Turn light (right front)               | 37 Pressure indicator           | 60 Toggle switch               |
| 16 Wiring harness, front                  | 38 Water temp indicator         | 61 Cab heater                  |
| 17 Wiring harness, rear                   | 39 Fuel indicator               | 62 Wire Humbly                 |
| 18 Wiring harness, outrigger              | 40 Wire assembly                | 63 Wire assembly               |
| 19 Turn light (right rear)                | 41 Cable                        | 64 Outlet                      |
| 20 Blackout tail light                    | 42 Slave receptacle             | 65 Wire harness                |
| 21 Turn light (left rear)                 | 43 Battery Cable (jumper)       | 66 Rheostat                    |
| 22 Wire harness, transmission             | 44 Battery Cable (ground)       | 67 Dash light                  |
|   | 45 Battery Cable (positive)     | 68 Dome light                  |

**Figure 3. Crane-shovel and carrier wiring diagram.**

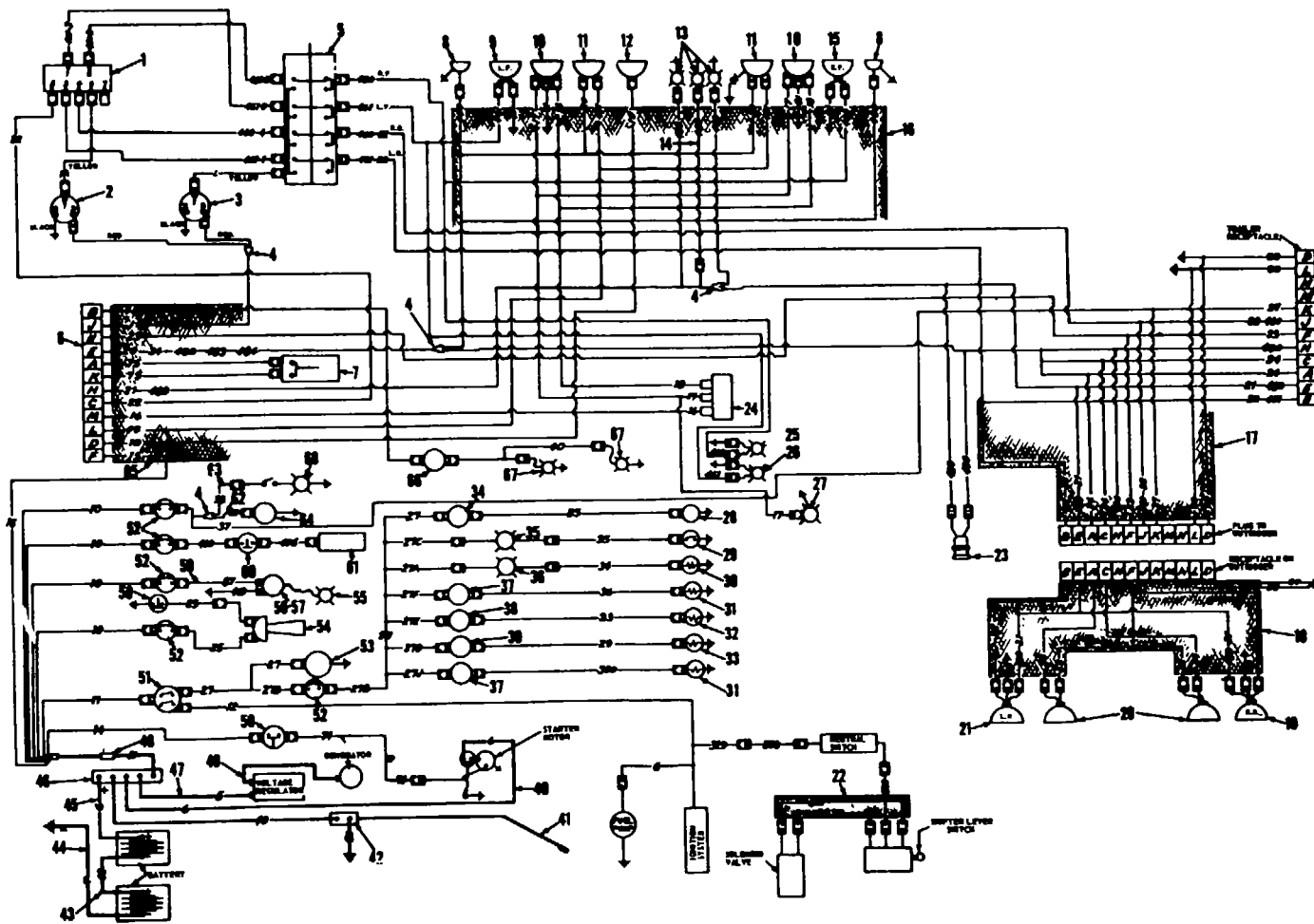

AGO6819A

A - Carrier Wiring Diagram.

Figure 3 - Continued

MEC 3810-227-15/3(1)

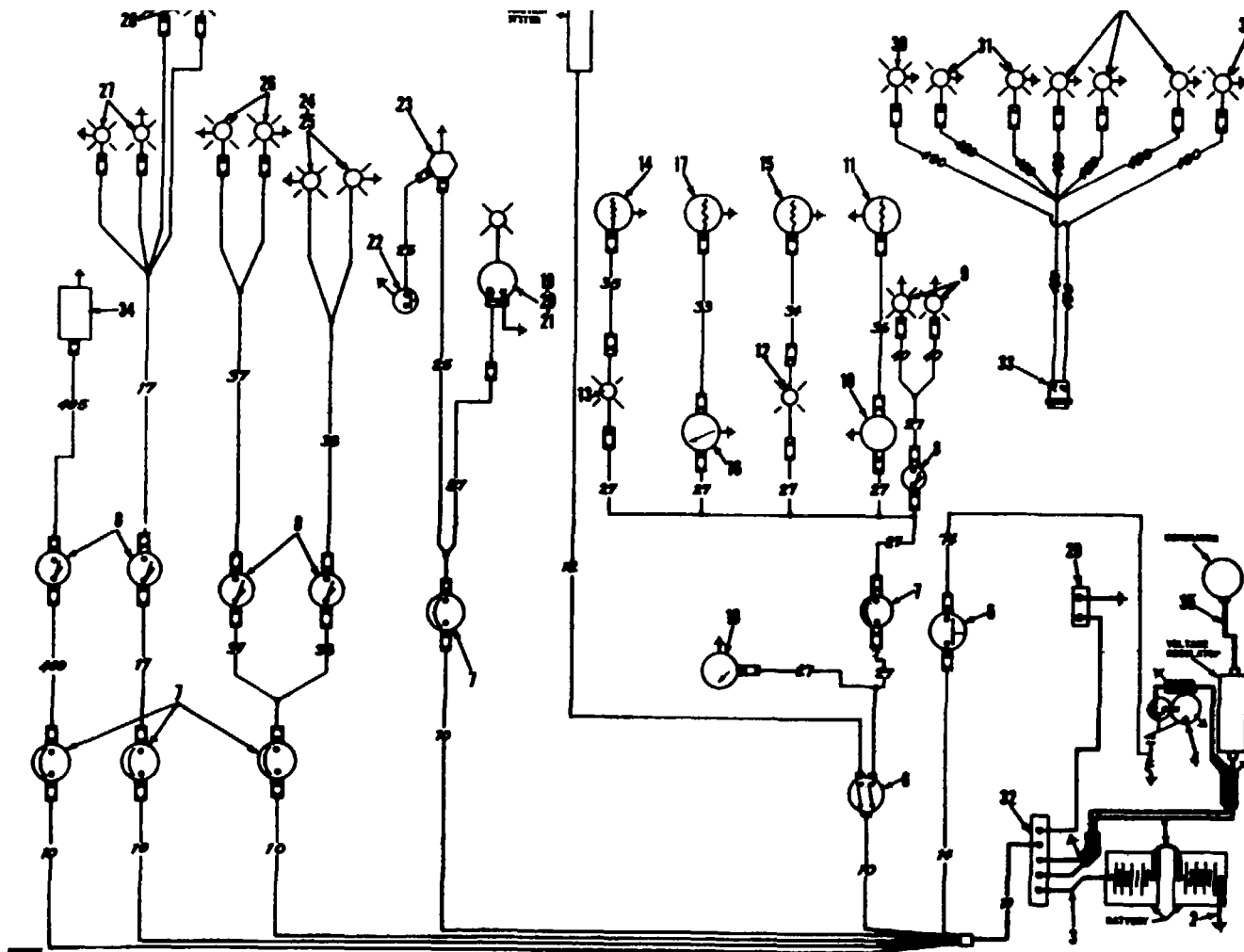

- 1 Battery Cable (jumper)
- 2 Battery Cable (ground)
- 3 Battery Cable (positive)
- 4 Starter motor
- 5 Starter switch
- 6 Ignition switch
- 7 Circuit breaker
- 8 Toggle switch
- 9 Dash light
- 10 Pressure indicator (oil)
- 11 Pressure transmitter (oil)
- 12 Indicator light (low-oil)
- 13 Indicator light (Hi-temp)
- 14 Temperature warning switch
- 15 Low Oil Pressure sending unit
- 16 Temperature indicator
- 17 Temperature sending unit
- 18 Battery-Generator indicator
- 19 Pistol grip and reel
- 20 Pistol grip holder
- 21 Trouble lamp
- 22 Horn switch
- 23 Horn
- 24 Cab light adapter
- 25 Cab light
- 26 Skirt floodlight
- 27 Top floodlight (right)
- 28 Top floodlight (left)
- 29 Slave receptacle
- 30 Blackout clearance light
- 31 Service marker
- 32 Bus bar
- 33 Wire assembly
- 34 Heater
- 35 Cable (generator)

B - Crane Wiring Diagram.

B - Crane Wiring Diagram.

Figure 3 - Continued.

i. *Cue Boom Angle and Height Data.* The boom angle, height from ground, and distance from center of rotation are listed in table 2.

**Table 2. Crane Boom Angle and Height Data**

Boom length in feet	Angle in degree	Distance from center of rotation
30	25	30
30	43	25
30	55	20
30	66	15
30	76	10
40	22	40
40	37	35
50	42	40
50	50	35
50	57	30
50	64	25
50	70	20
50	76	15
60	38	50
60	46	45
60	53	40
60	58	35
60	63	30
60	69	25
60	74	20
60	78	15
70	48	50
70	53	45
70	58	40
40	48	30
40	57	25
40	65	20
40	73	15
40	77	12
50	20	50
50	33	45
70	63	35
70	67	30
70	72	25
70	76	20
80	54	50
80	58	45

Boom length in feet	Angle in degree	Distance from center of rotation
80	62	40
80	66	35
80	70	30
80	73	25
90	58	50
90	62	45
90	66	40
90	69	35
90	73	30
90	76	25

j. *Weight of Material.* Listed below are the weights of materials per 3/4 cubic yard, in pounds, commonly handled with the cranes shovel. These weights are approximate and should be used only as a general guide. Be sure to add the weight of the bucket to determine the total load on clamshell and dragline operation. For materials not listed here, refer to FM 5-35.

<i>Material</i>	
Ash, dry.....	700 lb
Cinders.....	1,000-1,200 lb
Clay, compact.....	2,900 lb
Clay, dry lumps.....	1,700 lb
Coal anthracite .....	1,200-1,500 lb
Coke.....	2,000 lb
Concrete, ready-to-pour.....	3,000 lb
Earth, dry, loose .....	2,000 lb
Earth, dry, packed .....	2,500 lb
Earth, mud, packed .....	8,000 lb
Gravel, loose, dry .....	2,400-2,800 lb
Gypsum, crushed.....	1,900 lb
Gravel, wet, packed.....	2,700-8,200 lb
Iron ore (50% iron).....	4,800-4,800 lb
Limestone, 1 1/2 to 2 in. grade.....	4,450 lb
Limestone, run of crusher.....	2,000 lb
Sand, dry, loose.....	2,400-2,800 lb
Sand, Wet, packed.....	8,200 lb

## CHAPTER 2

### INSTALLATION AND OPERATION INSTRUCTIONS

---

#### Section I. SERVICE UPON RECEIPT OF EQUIPMENT

##### 7. Unloading Crane-Shovel

a. *Blocking and Tiedown Removal.* Remove the blocking and tiedowns as instructed on figure 4.

b. *Ramp Unloading.*

- (1) Construct an unloading ramp as illustrated on figure 4.
- (2) Perform all necessary daily preventive maintenance services (para. 38).
- (3) Drive the crane-shovel off the ramp.

**Caution:**

**Move the crane-shovel down the ramp slowly so it will be under control at all times.**

c. *Lifting the Crane-Shovel.* Attach the necessary slings and spreaders to the lifting eyes (fig. 4) of the crane-shovel and to the hook of a suitable lifting device. Lower the crane-shovel and remove the slings.

**Caution:**

**Be sure the lifting device has a capacity of 28 tons or over.**

##### 8. Unpacking New Equipment

a. *Unpacking.*

- (1) *Crane accessories.* Crane accessories such as lights, batteries, windshield wiper, and rearview mirror will arrive in boxes packed in waterproof paper. Use care in removing cover from boxes; pull nails to remove boards. Gouging with a bar might damage contents of boxes. The remaining items are wrapped in waterproof and pressure-sensitive tape and stored in the toolbox.

- (2) *Crane components.* Crane components such as hoist cable and fairlead are packed in wooden crates (fig. 4). Remove the components from the crates.

- (3) *Inspect.* Inspect the equipment against the packing list and report all discrepancies to the proper authority.

b. *Removal of Protective Material and Devices.*

Prepare the crane-shovel for inspection and/or operation as outlined on DA Form 2258, attached on or near the operator's controls.

##### 9. Inspecting and Servicing Now Equipment

a. *Inspecting New Equipment.*

- (1) Make a complete visual inspection to make sure the required tools, repair parts, and publications are with the equipment.
- (2) Visually inspect the carrier and crane engines and mounted components for missing items or damage that may have occurred during loading, shipment, or unloading.
- (3) Inspect wiring, fuel and oil lines, radiator and hoses, fuel tanks, gag, instruments, and lights for missing items and broken, loose, or damaged, parts.
- (4) Inspect the drain plugs, breathers, filler caps, and draincocks to be sure they are secured and not leaking or damaged.
- (5) Inspect the tires, airbrake hose, and electrical leads for cuts, breaks, cracks, or signs of deterioration. Correct or report any deficiencies noted and corrected to field maintenance.

AGO 6819A

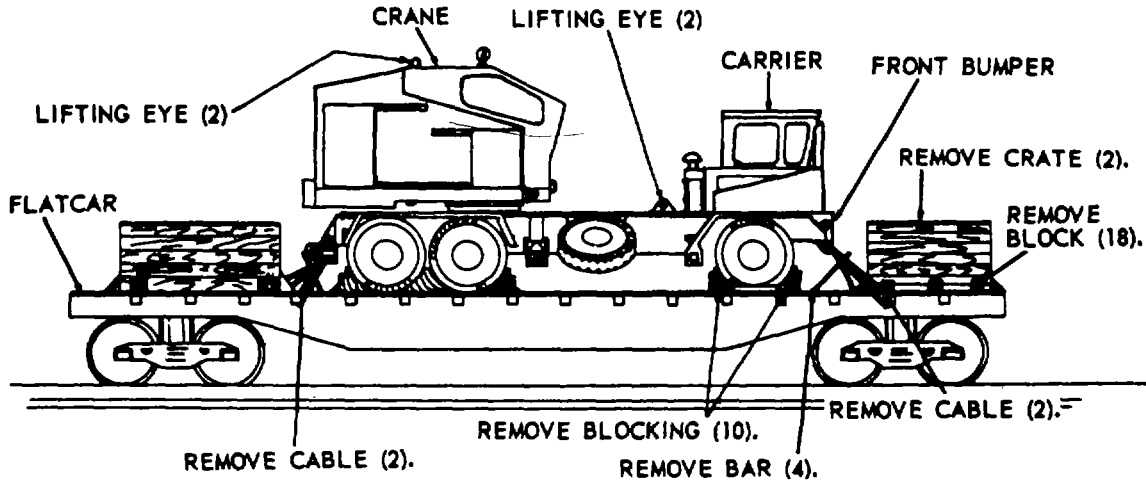

A - Crane-shovel Blocking and Tiedown, Removal.

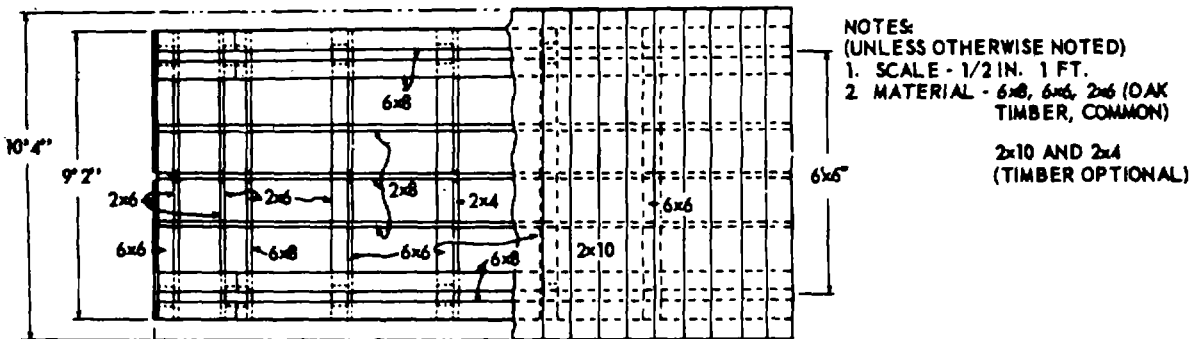

NOTES:  
 (UNLESS OTHERWISE NOTED)  
 1. SCALE - 1/2 IN. 1 FT.  
 2. MATERIAL - 6x8, 6x6, 2x6 (OAK  
 TIMBER, COMMON)  
 2x10 AND 2x4  
 (TIMBER OPTIONAL)

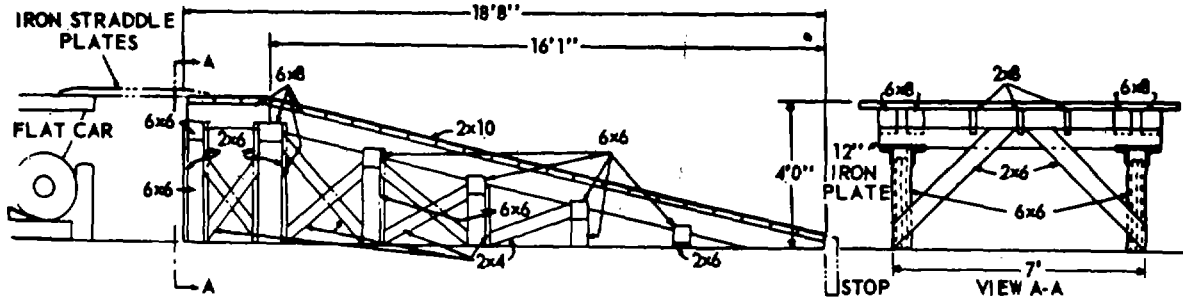

B - Unloading Ramp Construction.

MEC 3810-227-15/4

Figure 4. Crane-shovel unloading instructions.

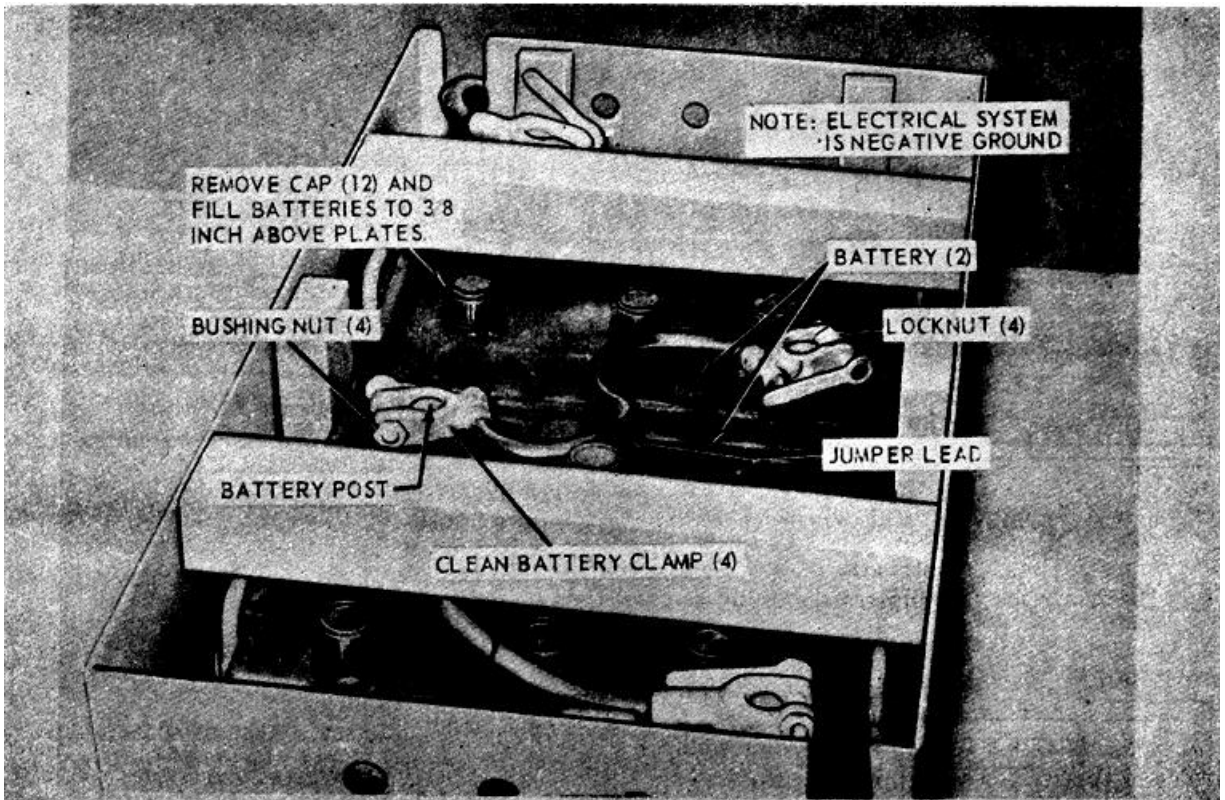

A - Carrier Batteries.

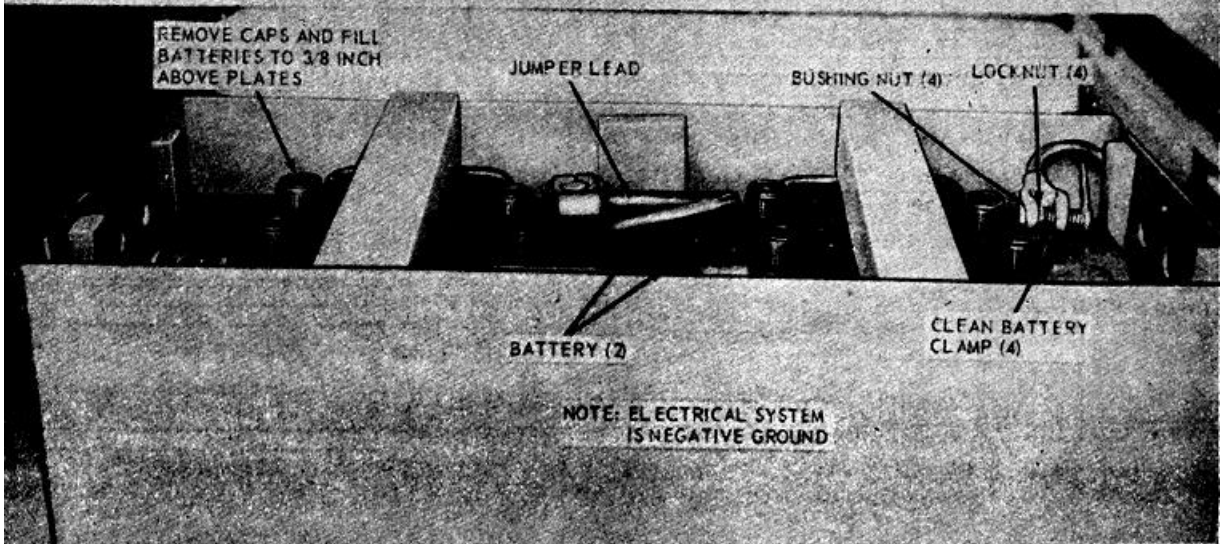

B - Crane Batteries.

MEC 3810-227-15/5

Figure 5. Batteries, installation and removal.

b. *Servicing New Equipment.*

- (1) Perform the necessary daily preventive maintenance services (para. 38).
- (2) When the crane-shovel is received with new, dry-charge batteries, and electrolyte is packed separately, perform the following services:
  - (a) Remove the battery box cover and filler caps as shown in figure 5.
  - (b) Pour electrolyte into each battery cell to a depth of  $\frac{1}{8}$  inch above the separators.

- (c) Install the filler caps and battery box cover.

**Caution:**

**Exercise care when filling the batteries with electrolyte to prevent splashing or spilling the acid on clothing and body.**

**Note.**

**The carrier and crane batteries are serviced in the same manner.**

## Section II. FRONT END ATTACHMENT, INSTALLATION AND REMOVAL

### 10. Installation or Setting-Up Instructions

The crane-shovel is shipped semi-assembled. Installation or setting-up instructions consist of installing the front end attachment on the basic unit.

a. *Positioning The Carrier.* The carrier should be positioned so as to afford the crane operator the best and safest working angle and the firmest support for the unit regardless of type of work to be done.

b. *Positioning The Outriggers.* Position the front and rear outriggers (fig. 6).

### 11. Conversion for Crane Operation

a. *General.* The equipment used to convert the crane-shovel for crane operation consists of a boom, boom hoist cable, bridle sheave assembly, and telescoping pipes. A boom extension may be used to increase the length of the main boom. Adequate tools and organizational maintenance personnel will be needed to install crane attachment.

b. *Crane Room Installation.*

- (1) With the crane facing toward the rear of the carrier, back the unit into position, aligning the main frame boom support holes of the crane with the crane boom holes.
- (2) Using a suitable lifting device, lift the boom into position, aligning the bottom holes of the main frame boom support with the holes in the boom, and install the two boom footpins and cotter pins (fig. 7).
- (3) Install telescoping pipes of boom stop to top of gantry (fig. 121).
- (4) Install telescoping pipes of boom stop to boom (fig. 121).

- (5) Secure the two pendant cables to the boom point links (fig. 121).
- (6) Secure the bridle sheave assembly to the pendant cables (fig. 121).

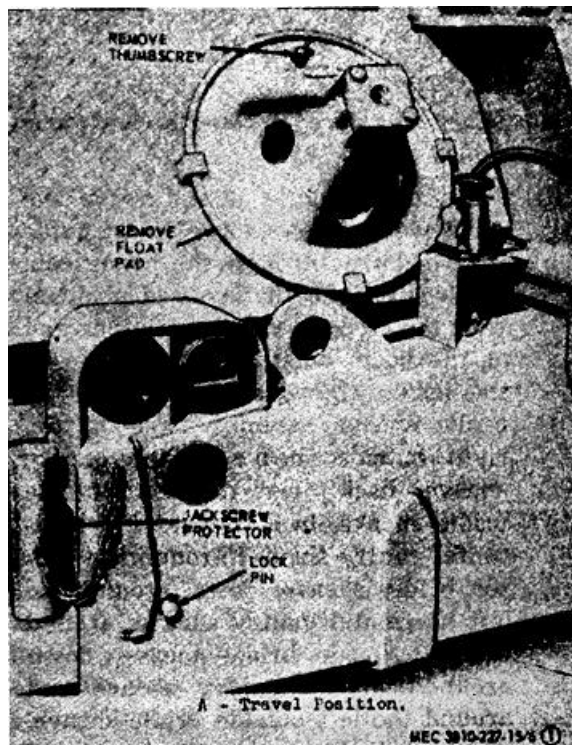

Figure 6. Outriggers.



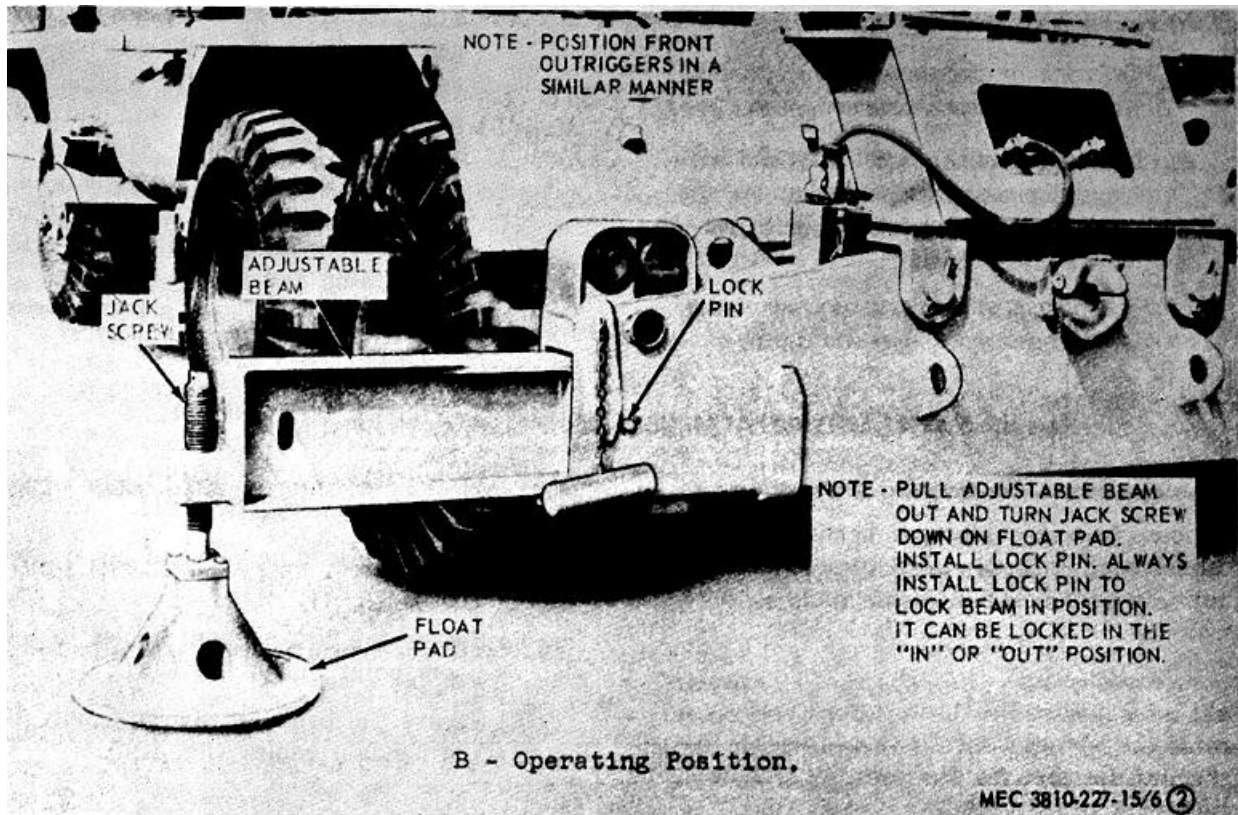

Figure 6 - Continued.

c. *Cable Reeving.*

- (1) Select the proper length and size cables (para. 12).
- (2) Refer to B, figure 8 and reeve the cable over the top gantry center guide sheave down through the crane cab, and secure it to the boom hoist drum with the wedge. Reeve the other end of the boom hoist cable over top of the inside right-hand sheave of the bridle sheave assembly, around the right outside sheave of the gantry sheave, back over the top outside bridle sheave, back around the horizontal gantry sheave, around the center bridle sheave, down around the left horizontal gantry sheave, around the left inside bridle sheave, down around the left gantry sheave and around the left outside bridle sheave, and back to the anchor on the gantry and secure with the cable wedge.

- (3) Reeve from the right hand drum on the hoist drum shaft to the right crane boom point sheave, through the right side sheave of the hook block, over the top of the center boom point sheave, through the left side sheave of the hook block, over the top of the left crane boom point sheave, and then deadend the cable at the hanger.

d. *Crane Boom Removal.*

- (1) Lower the boom to a horizontal position and build up cribbing under the boom as illustrated in figure 9.
- (2) Use wedges or jacks to relieve weight from the boom footpins. Remove the cotter pins and boom footpins.
- (3) Remove the cables; clean, lubricate, and identify the cables; and store.
- (4) Move the crane away from the crane boom attachment.

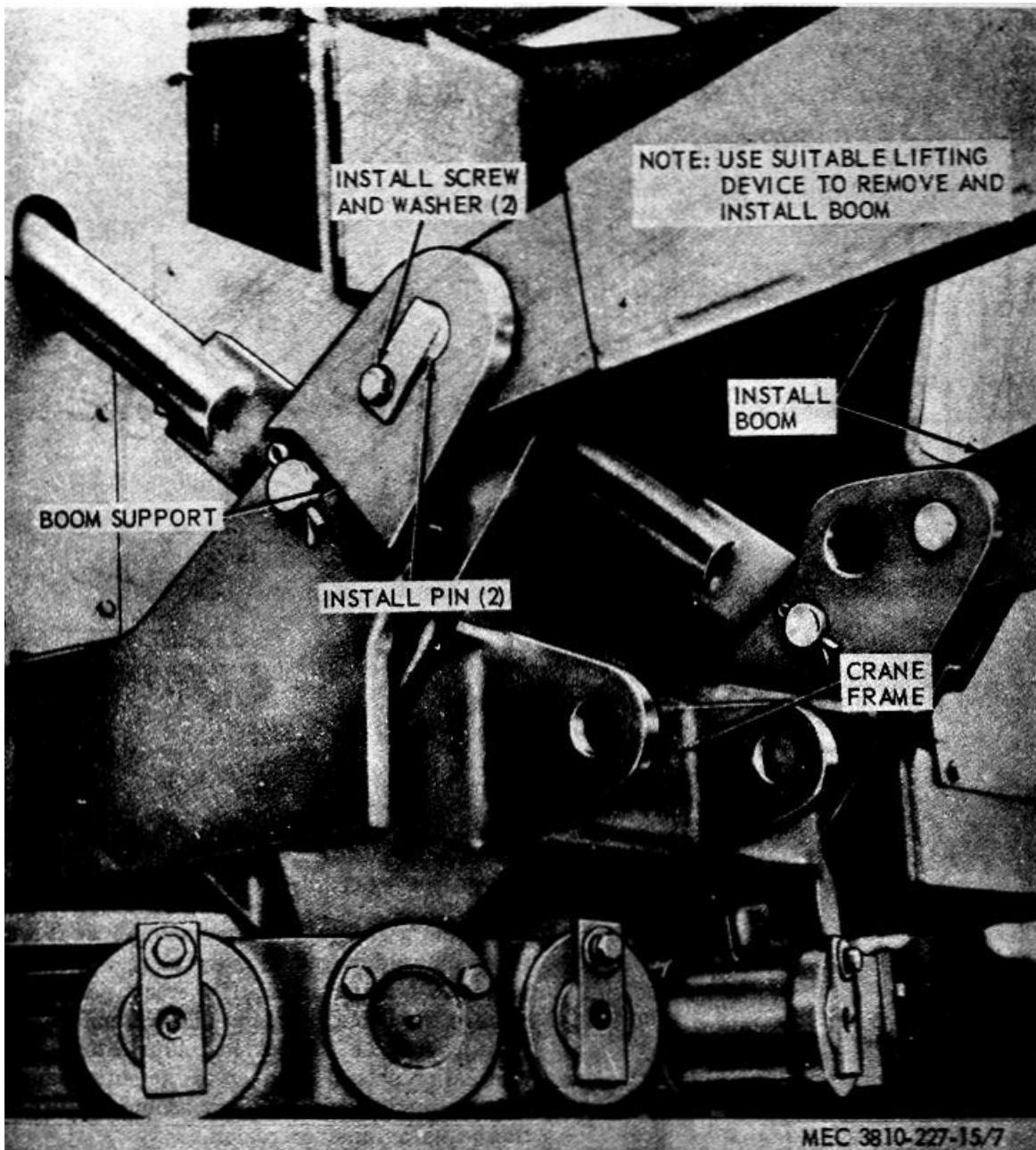

Figure 7. Crane boom, removal and installation.

## 12. Care and Application of Cables

*a. General.* For proper operation of equipment and longest cable life, replace all faulty cables with others of the same specifications. Abuses such as kinking and lack of lubrication will greatly shorten the life span of the cables.

*b. Unreeling and Reeling Cable* (fig. 10). To avoid kinking the cables, revolve reel (A) and take the cable

off in the same manner as it was put on. Put a shaft through the center of the reel and support the reel so that it revolves freely. Hold a board or bar against one flange to prevent the cable from unwinding too freely. Pull the cable from the reel in a straight line. Do not place the reel on its side and pull the line over the flange (B). If possible, a cable on idle equipment should be cleaned, lubricated, wound on a reel in the same

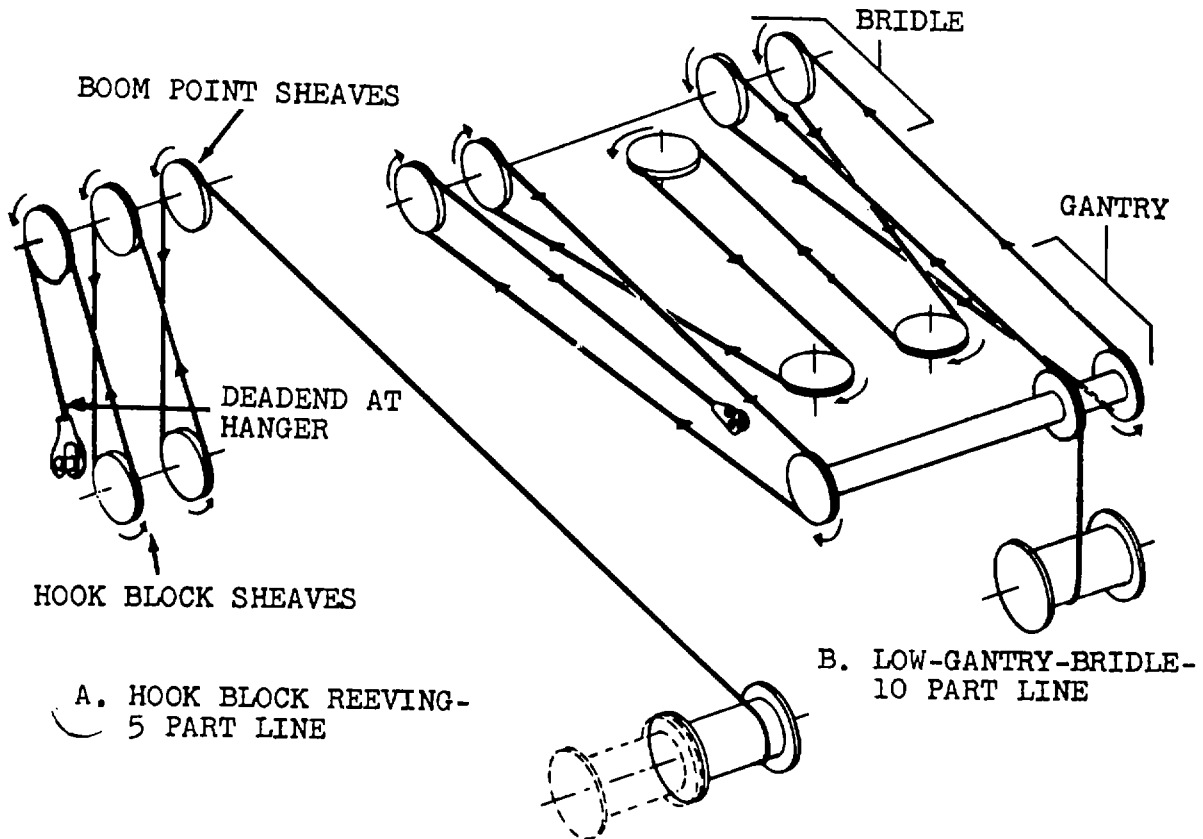

MEC 3810-227-15/8

Figure 8. Crane boom reeving diagram.

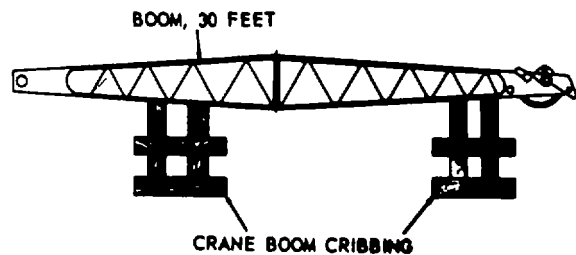

NOTE: MAKE SURE CRIBBING IS SET ON FIRM GROUND TO AVOID UPSETTING OF BOOM, CAUSING INJURY TO PERSONNEL AND DAMAGE TO ATTACHMENT.

MEC 3810-227-15/9

Figure 9. Crane boom cribbing method.

manner as it was taken off, and stored in a dry place where it is protected from weather. If it is not possible to remove the cable from the idle equipment, the cable should be cleaned and lubricated. This lubrication should be given to the entire length of cable, and should be heavy enough to protect the wires against corrosion.

c. *Uncoiling Cable* (fig. 10). Unbind the coil and roll it along the ground (C) so that it lies in a straight line. There will be no kink or twist in the cable when it is taken up on the crane drum if it is taken from this position. Do not drop the coil and pull the cable off (D).

d. *Breaking in New Cable*. When a new cable has been installed, it is advisable to operate without a load for a short time. This is done to allow the cable to shape itself to the drums and sheaves. It is also advisable to

AGO 6819A

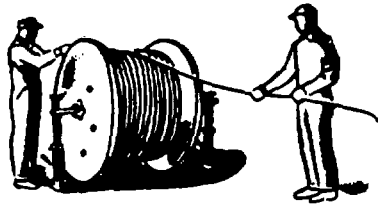

**A**  
**CORRECT WAY**

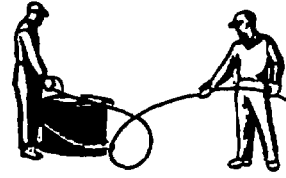

**B**  
**INCORRECT WAY**

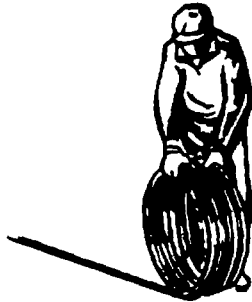

**C**  
**CORRECT WAY**

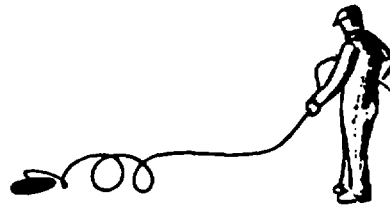

**D**  
**INCORRECT WAY**

MEC 3810-227-15/10

Figure 10. Cable handling.

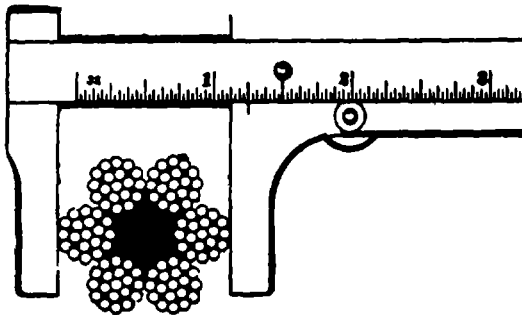

**CORRECT WAY**

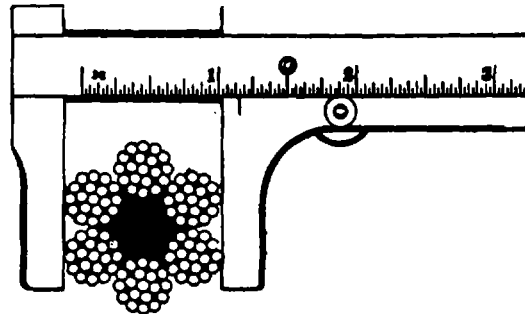

**INCORRECT WAY**

MEC 3810-227-15/11

Figure 11. Measuring cables.

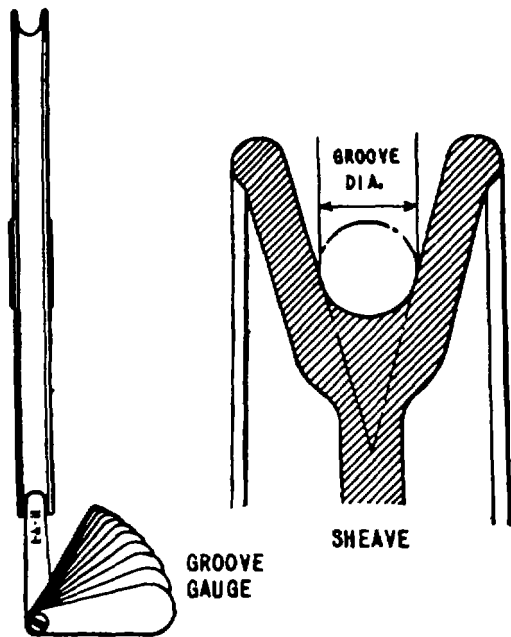

MEC 3810-227-15/12

Figure 12. Measuring groove diameter.

remove the wedge from the socket and allow the cable to assume its natural position and to eliminate the initial twist that a new cable may develop.

e. *Measuring Cable and Sheave Throat.* For prolonging cable life, the diameter of a new cable should be slightly smaller than the sheave groove diameter. Cable diameter is measured across the flats (fig. 11). Since the cable diameter decreases through wear, it will have a tendency to wear the cable groove in the sheave. If a new cable is installed on sheaves with worn grooves, rapid wear to the new cable will result. Cable sheaves and lagging should be checked periodically by using a cable gauge to see if the sheaves need replacing (fig. 12).

### Section III. CONTROLS AND INSTRUMENTS

#### 13. General

This section describes, locates, illustrates, and furnishes the operator, crew, or driver sufficient information about the various controls and instruments for proper operation of the crane carrier and crane-shovel.

#### 14. Carrier Controls and Instruments

a. *Turn Signal Lever* (A, fig. 13). The turn signal lever is a three-position control lever and is located on the left side of the steering column under the steering wheel. When the lever is pushed up the turn signal lights on the right front and rear of the carrier flash on and off indicating a right turn. When the lever is pulled down, lights flashing on the left front and rear of the carrier indicate a left turn.

b. *Trailer Brake Lever* (A, fig. 13). The trailer brake lever is located on the right side of the steering wheel and is used to control the air braking pressure to a trailer or similar towed unit.

c. *Gear Shift Lever* (A, fig. 13). The gear shift lever is located to the right of the operator's seat. It controls the selection of the forward and reverse speeds of the transmission. The gear shift chart mounted on the right panel of the cab shows the relative position of the gear shift lever for each of the transmission speeds.

d. *Transfer Case Shift Lever* (A, fig. 13). The transfer case shift lever is the second lever to the right of the operator's seat. This lever controls the selection of the "high" and "low" speed range of the transfer case.

e. *Hand Brake Lever* (A, fig. 13). The hand brake lever is located on the floor board to the right of the accelerator pedal and operates a drum-type brake on the propeller shaft. To set the brake, pull up and back on the lever until it snaps over center and locks. To release the brake, push forward and down on the lever. The linkage may be adjusted by turning the top portion of the lever clockwise to tighten and counter clockwise to loosen.

AGO 6819A

f. *Accelerator Pedal* (A, fig. 13). The accelerator pedal is located on the floorboard to the right of the brake pedal and controls the carburetor accelerator mechanism which regulates the fuel-air mixture fed to the engine. Depress the pedal to increase the speed. When pressure is released the pedal will return to its normal position.

g. *Brake Pedal* (A, fig. 13). The brake pedal is located on the floorboard immediately to the right of the steering column and actuates the air brake valve and controls the air being delivered to, or released from the brake chambers.

h. *Clutch Pedal* (A, fig. 13). The clutch pedal is located on the floor directly to the left of the steering column. The clutch is used to engage or disengage the engine from the transmission to permit shifting gears. The clutch pedal is pushed in to disengage and let out to engage the clutch.

i. *Panel Light Rheostat*. (B, fig. 13). The panel light rheostat is located at the extreme left of the carrier control panel and provides control of the instrument panel lights. They can be turned up or down to the desired illumination required.

j. *Light Switch* (B, fig. 13). The light switch assembly is located at the left side of the carrier control panel and is used to control the lights on the crane carrier. The switch assembly has three lever type switches. The lower left lever controls the instrument panel lights and the parking lights. The lower right lever is a two position lock lever.. The top control lever controls the service and blackout lights. Lever positions are marked on the switch.

k. *Battery-Generator Indicator* (B, fig. 13). The indicator is located on the instrument panel to the left of the speedometer. This instrument indicates the condition of the batteries when the engine is running or stopped. The ignition switch must be in the ON position, before the indicator will show battery condition. If the needle is in the RED part of the dial batteries are dangerously low and need immediate attention. If the needle is in the YELLOW area the batteries are in a weakened condition and should be serviced or charged during the next regular maintenance period. When the needle is in the GREEN

part of the dial, the batteries are properly charged for normal operation.

l. *Warning Lights* (B, fig. 13). There are two warning lights on the instrument panel. The one on the left, next to the oil pressure gage gives a red light when the oil pressure is below the operating minimum. The light on the lower right of the instrument panel, next to the water temperature gage gives a red light when the water temperature is above the safe operating maximum.

m. *Oil Pressure Gage* (B, fig. 13). The oil pressure gage is located to the left of the speedometer and indicates the engine lubricating oil pressure. Normal oil pressure at operating temperature and speed is 50 to 60 pound per square inch. With a cold engine, the pressure will exceed this. This gage should show pressure as soon as the engine is started. Failure of the oil pressure gage to operate is a danger signal. Stop the engine immediately and check the cause.

n. *Turn Indicator Lights* (B, fig. 13). The Turn indicator lights are mounted near the top of the instrument panel. The one on the left comes on when the turn signal lever is moved for a left turn. The one on the right comes on when the turn signal lever is moved for a right turn.

o. *Speedometer* (B, fig. 13). The speedometer is a circular, needle-type indicator calibrated from 0 to 60. It indicates the speed the vehicle is traveling and registers the miles traveled. It is located near the left center of the instrument panel.

p. *High Beam Indicator Light* (B, fig. 13). The high beam indicator light is located in the center, near the top, of the instrument panel. It gives a red light if the headlights are on high beam and goes off when the lights are switched to low-beam.

q. *Tachometer-Hourmeter* (B, fig. 13). The tachometer-hourmeter is located to the right of the speedometer and shows the engine revolutions per minute and registers the number of hours the engine operates.

r. *Air Pressure Gage* (B, fig. 13). The air pressure gage is located on the instrument panel to the right of the

tachometer-hourmeter and is calibrated from 0 to 120 pounds. It indicates the air pressure in the air brake system. The normal operating air pressure will range from 80 to 105 pounds per square inch.

s. *Choke Control* (B, fig. 13). The choke control is a push-pull type and is located near the extreme right of the carrier control panel. The choke is used to operate the choke valve in the carburetor when starting the engine.

t. *Flasher Warning Light Switch* (B, fig. 13). The flasher warning light switch is located at the extreme upper right of the carrier control panel. This switch is used when the vehicle is parked and allows the turn signal lights, both front and rear, to be turned on and keeps them flashing intermittently.

u. *Front Axle Declutch Control* (B, fig. 13). The front axle declutch control is located at the extreme lower right of the carrier control panel and engages and disengages the front axle drive. Push in on control to engage front axle, and pull out to disengage front axle drive.

v. *Dry-Wet Brake Switch* (B, fig. 13). The dry-wet brake switch is located on the lower right of the carrier control panel. This switch provides a means of changing the braking action of the carrier brakes depending on, the pavement or roadway conditions, whether a wet or dry surface. Switch positions are marked on the switch plate.

w. *Water Temperature Gage* (B, fig. 13). The water temperature gage is located on the right of the instrument panel, below the air pressure gage. This gage registers the temperature of liquid in the cooling system and should show a gradual increase in temperature during engine warm up, to a normal operating temperature of 160° to 180°F.

x. *Windshield Wiper Control* (B, fig. 13). The windshield wiper control is located at the right lower side of the carrier control panel below the water temperature gage. Turn clockwise to operate windshield wiper. Counter clockwise stops wiper operation.

y. *Ignition Switch* (B, fig. 13). The ignition switch is

mounted to the left of the windshield wiper control. It is a key-type switch. Turn key clockwise for engine operation and counterclockwise to stop the engine.

z. *Fuel Gage* (B, fig. 13). The fuel gage is located to the left of the water temperature gage. When the ignition switch is turned to ON position, the fuel gage will indicate the amount of fuel in the fuel tank.

aa. *Hand Throttle* (B, fig. 13). The hand throttle is located at the bottom of the carrier control panel just left of the steering column. Pull out to increase engine speed, push in to decrease engine speed. Turning the throttle clockwise will lock it in position.

bb. *Heater Switch* (B, fig. 13). This switch is located to the left of the hand throttle and operates the cab-heater on the non-winterized units. It has a hi-lo and off position marked on the switch.

cc. *Starter Button* (B, fig. 13). The engine starter button is located at the lower left of the heater-switch and is a push type button. It is used in conjunction with the ignition switch to start the carrier engine.

dd. *Tractor Protection Brake Control Valve* (B, fig. 13). The tractor protection brake control valve is mounted on the lower left on the carrier control panel. This control permits selecting service or emergency operation for the carrier brake. Lever positions are marked on the control.

ee. *Windshield Washer* (B, fig. 13). The windshield washer is located on the floorboard above and to the left of the clutch pedal. When pumped with the foot it sprays water from jets outside the windshield, permitting the windshield wiper to clean the windshield. Do not operate when temperature is below freezing.

ff. *Dimmer Switch* (B, fig. 13). The dimmer switch is located on the floorboard just below and to the left of the windshield washer. This provides a foot operated control to switch the headlight beam from low beam to high and vice-versa.

gg. *Carrier Heater Controls* (C, fig. 13) (Winterized Units Only). The winterized carrier units have two heaters, one for the engine and one for the cab and components. Both heater control boxes are mounted

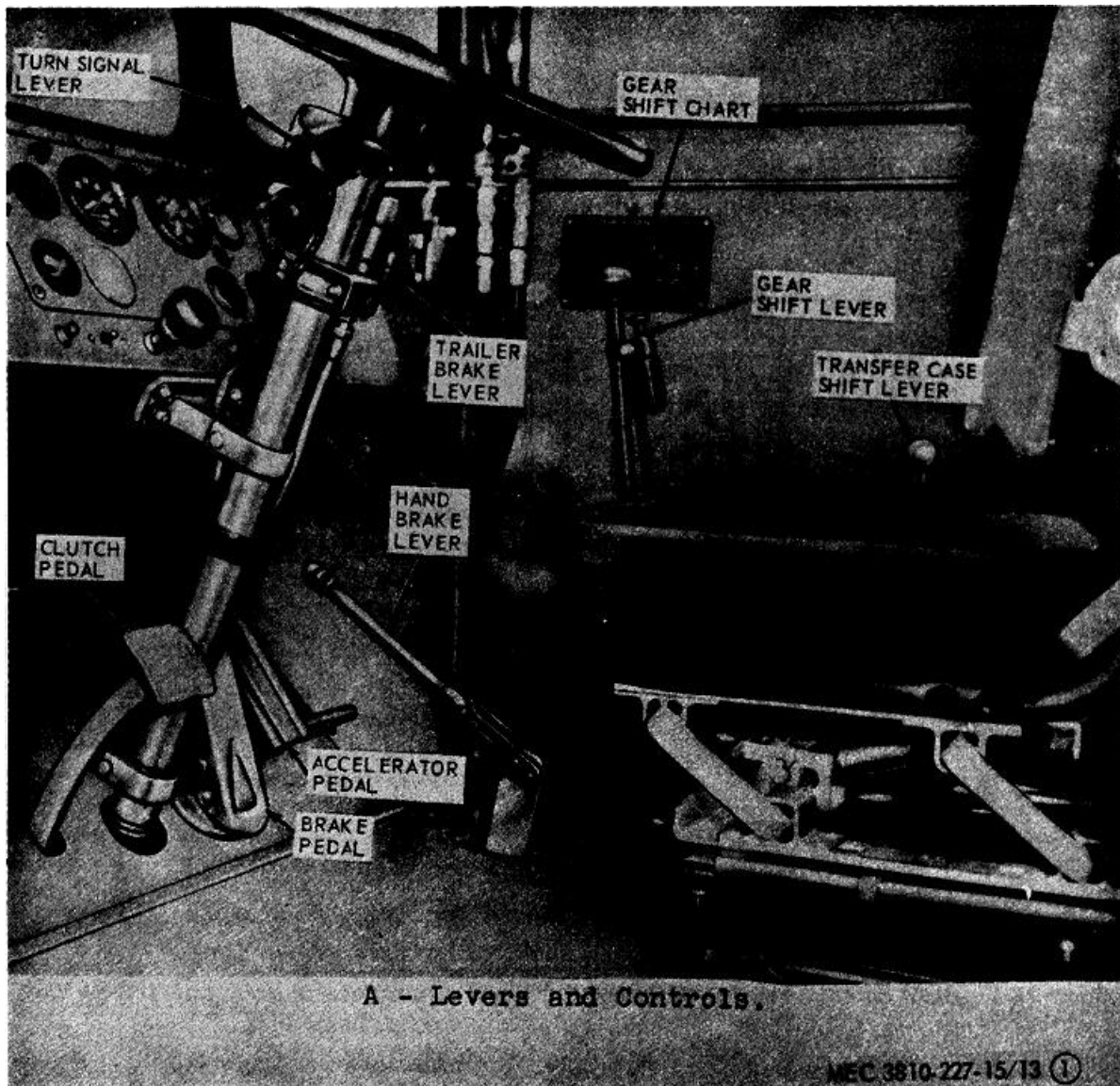

**Figure 13. Carrier controls and instruments.**

under the right side window defroster unit and are identical in operation. Each control box has three controls.

- (1) Indicator light (C, fig. 13). The function of the indicator light is to show when the heater is in operation. It is located on the left side of the control panel. The lamp glows constantly when the heater is on either high-fire or low-fire operation. It will also glow when the heater has just been shut off for approximately two minutes until

the heater starts to cool. The indicator light may be used as a check on the power supply to the heater. A spring-loaded terminal on the light socket is connected to the circuit breaker so that the lamp will light when pressed in if the circuit breaker is in, and power is available.

- (2) Circuit breaker (C, fig. 13). The circuit breaker is the center button of the heater control box. It is a safety device installed



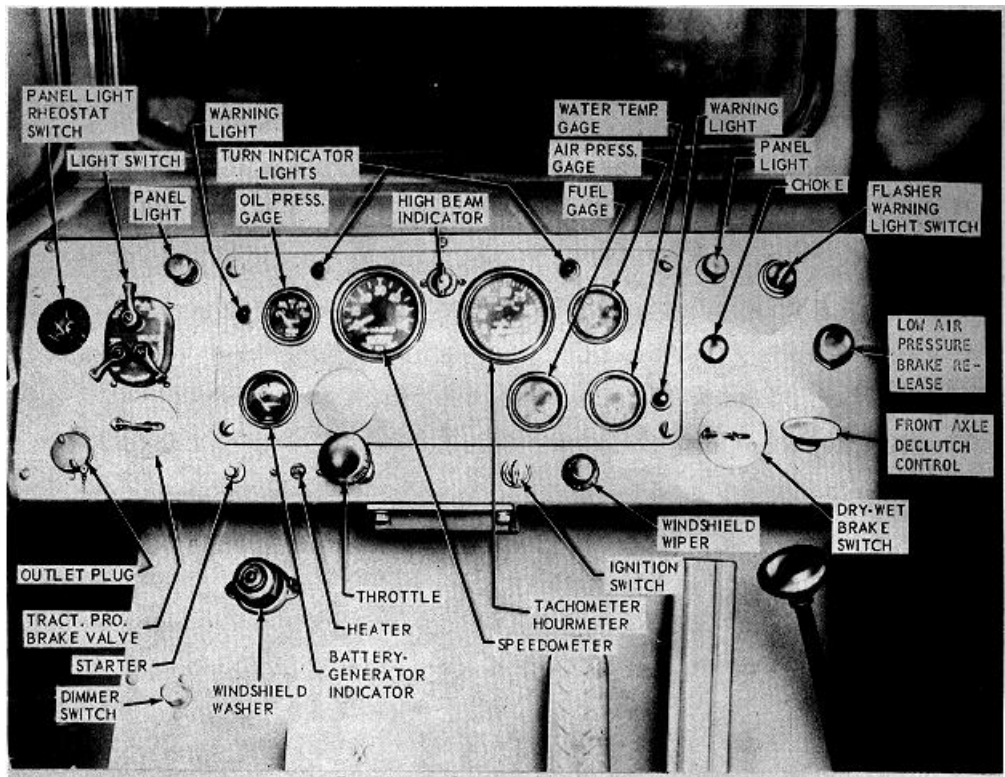

B - Controls and Instruments.

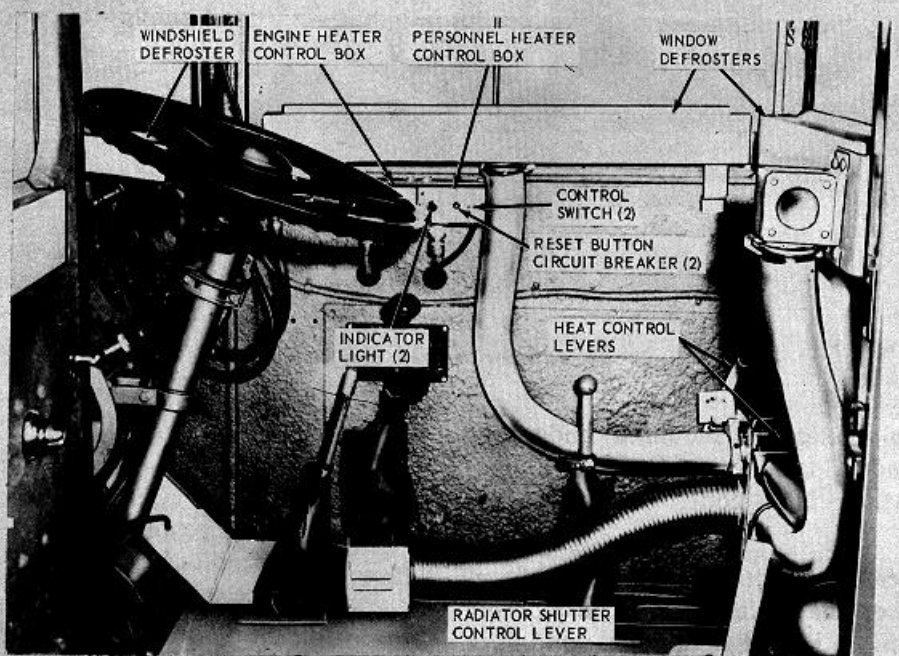

C - Heater and Shutter Controls (Winterized Units).

MEC 3810-227-15/13 (2)

Figure 13 - Continued.

AGO 6819A

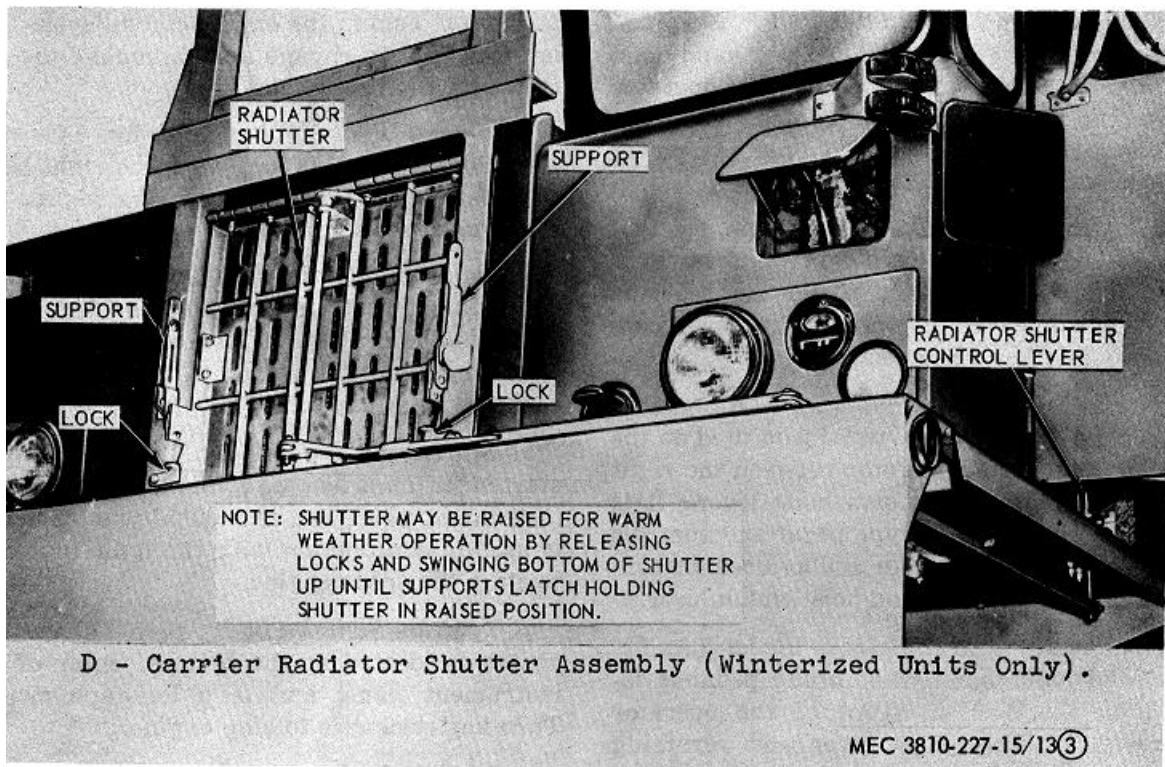

Figure 13 - Continued.

in the system to prevent current overloads from causing a fire hazard. To reset after tripping, press in the circuit breaker button.

**Caution:**

**Pulling out on the circuit breaker button breaks all electrical circuits to the heater. Do not attempt to stop heater operation with the circuit breaker. Stopping heater operation with the circuit breaker prevents the heater from purging itself at the end of the operating cycle.**

(3) *Control switch* (C, fig. 13). The control switch is located on the right side of the heater control panel. It is a three-position toggle-type switch with ON-HI (up), OFF (center) and ON-LO (down) used to select the desired heater range.

*hh. Radiator Shutter Control Lever* (C and D, fig. 13). The radiator shutter control lever is mounted on the cab

floor along the left side of the operator's seat. It has three positions; open, half, and closed.

*ii. Heat Control Levers* (C, fig. 13). The heat control levers are mounted in the duct work where it enters the cab at the back by the right side of the operator's seat. They provide control of the heat through the various ducts. They have four position settings from open to closed.

**15. Crane-Shovel Controls and Instruments**

*a. Reversing Clutch Lever* (A, fig. 14). The reversing clutch lever is located in front of the operator and to the left. This lever controls the direction of the swing motion of the revolving superstructure.

*b. Horn Button* (A, fig. 14). The horn button is mounted at the handle end of the reversing clutch lever. Press button to sound crane-shovel horn.

*c. Boom Hoist Lever* (A, fig. 14). The boom hoist lever is located directly in front of the operator to the right of the reversing clutch lever and controls the boom hoist clutch.

d. *Right Hand Hoist Clutch and Power Load Lowering Lever* (fig. 14). The right hand hoist clutch lever is located in front of the operator and to the right. This lever controls the right hand hoist clutch and is also used for power load lowering.

e. *Left Hand Hoist Clutch Lever* (A, fig. 14). The left hand hoist clutch lever is located in front of the operator and to the right of the right hand hoist clutch lever. This lever controls the left hand hoist clutch.

f. *Left Hand Hoist Brake Pedal* (A, fig. 14). The left hand hoist brake pedal is located on the floor in front of the operator between the right hand hoist clutch and boom hoist lever. It is a toe lock, heel release type pedal and controls the left hand hoist brake and is used in conjunction with the left hand hoist clutch lever.

g. *Right Hand Hoist Brake Pedal* (A, fig. 14). The right hand hoist brake pedal is located on the floor in front of the operator between the boom hoist lever and reversing clutch lever. It is a toe lock, heel release type pedal and controls the right hand hoist brake and is used in conjunction with the right hand hoist clutch lever.

h. *Throttle* (A, fig. 14). The engine throttle is mounted on the structural frame to the right of the operator's seat. It is used to increase and decrease the engine speed.

i. *Safety Pawl Lever* (A, fig. 14). The safety pawl lever is mounted on the structural frame below and slightly forward of the throttle. This lever is used to disengage the safety pawl that locks the boom hoist.

j. *Cab Lock Lever* (A, fig. 14). The cab lock lever is located to the right and slightly behind the operator's seat. This lever is used to lock the revolving superstructure in position and prevent from turning.

k. *Engine Clutch Lever* (A, fig. 14). The engine clutch lever is located to the right and behind the operator's seat, and is connected to the engine or main clutch through linkage. This lever is used to engage and disengage the engine clutch.

l. *Jaw Clutch Lever* (A, fig. 14). The jaw clutch lever is located to the right of the operator's seat behind

the engine clutch lever. This lever is used to engage and disengage the jaw clutch on the boom hoist shaft.

m. *Swing Brake Wheel* (A, fig. 14). The swing brake wheel is located to the right below the operator's seat and is used to engage and disengage the swing brake.

n. *Panel Lights* (B, fig. 14). The two instrument panel lights mounted at the top of the crane instrument panel are controlled by the lower toggle switch at the extreme right hand corner of the panel.

o. *Starter Button* (B, fig. 14). The engine starter button is located at the top center of the instrument panel and is a push-type button. It is used in conjunction with the ignition switch to start the crane engine.

p. *Ignition Switch* (B, fig. 14). The ignition switch is located at the bottom center of the instrument panel and is a key-tape switch. Turn key clockwise to stop engine.

q. *Choke* (B, fig. 14). The choke control is mounted at the bottom of the instrument panel directly below the ignition switch and is the push-pull type. The choke is used to operate the choke valve in the carburetor when starting the engine.

r. *Oil Pressure Gage* (B, fig. 14). The oil pressure gage is located at the top left of the instrument panel and indicates the engine lubricating oil pressure. Normal oil pressure at operating temperature and speed is 40 to 50 pounds per square inch. With a cold engine, the pressure will exceed this. The gage should show pressure as soon as the engine is started. Failure of the oil pressure gage to operate is a danger signal. Stop the engine immediately, and check the cause.

s. *Water Temperature Gage* (B, fig. 14). The water temperature gage is located on the left side of the instrument panel directly below the oil pressure gage. This gage registers the temperature of liquid in the cooling system and should show a gradual increase in temperature during engine warm up, to a normal operating temperature of 160° to 180° F.

t. *Battery-Generator Indicator* (B, fig. 14). The indicator is located at the bottom left of the instrument

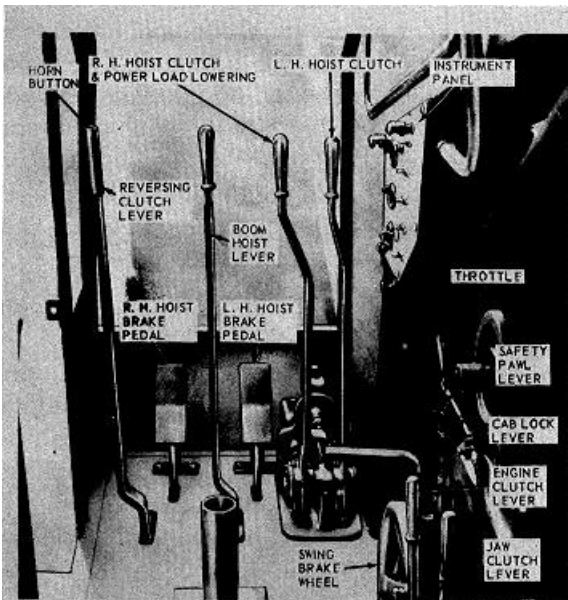

A - Controls and Levers

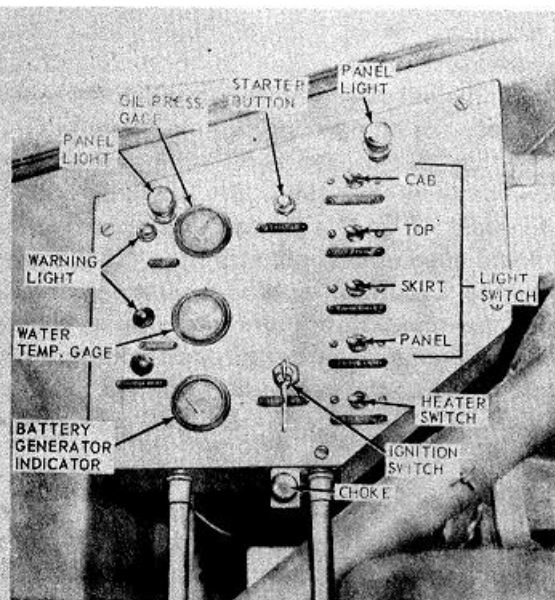

B - Controls and Instruments

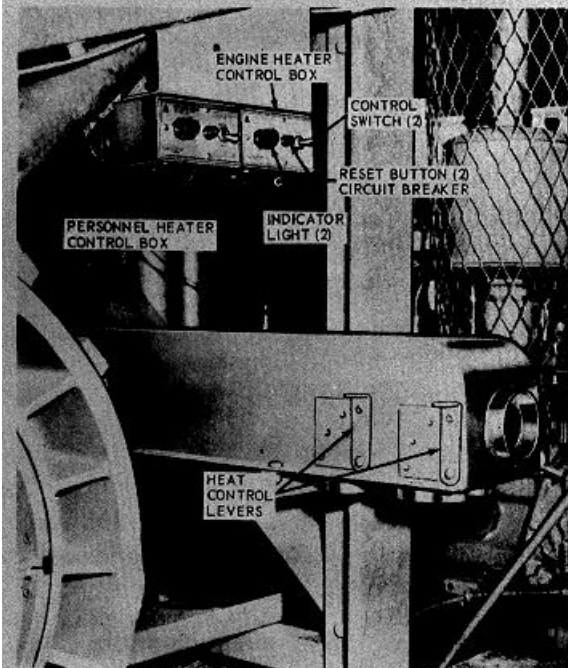

C - Heater Controls (Winterized Units Only)

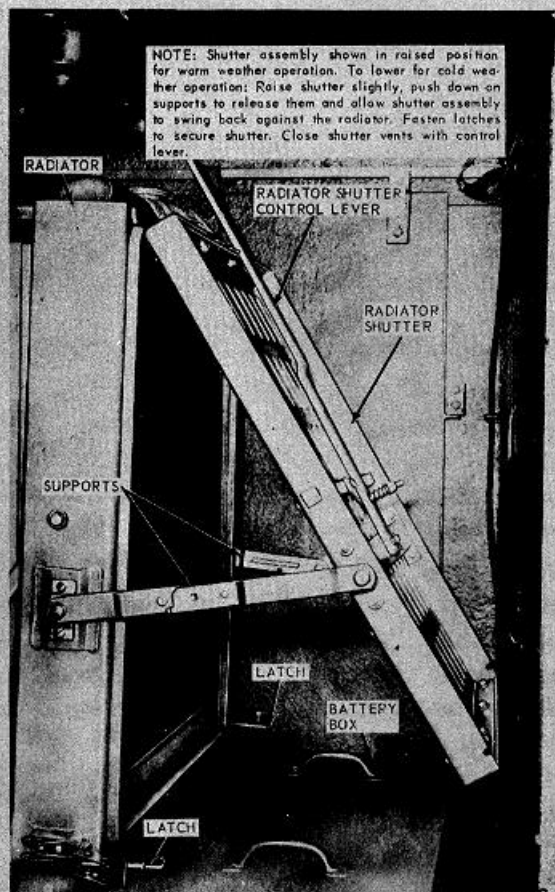

D - Radiator Shutter (Winterized Units Only)

MEC 3810-227-15/14

Figure 14. Crane controls and instruments.

panel directly below the water temperature gage. This instrument indicates the condition of the batteries when the engine is running or stopped. The ignition switch must be in the ON position before the indicator will show battery condition. If the needle is in the RED part of the dial batteries are dangerously low and need immediate attention. If the needle is in the YELLOW area the batteries are in a weakened condition and should be serviced or charged during the next regular maintenance period. When the needle is in the GREEN part of the dial, the batteries are properly charged for normal operation.

u. *Warning Lights* (B, fig. 14). There are two warning lights on the crane instrument panel. The light next to the oil pressure gage gives a red light when the oil pressure is below operating minimum. The light next to the water temperature gage gives a red light when water temperature is above the safe operating maximum.

v. *Heater Switch* (B, fig. 14). This switch is the bottom switch in the row of switches of the right hand side of the instrument panel and operates the cab heater on the non-winterized units. It has hi-lo and off positions marked on the switch.

w. *Light Switches* (B, fig. 14). The first three switches in the row of switches on the instrument panel operate the cab and floodlights on the crane. They are a toggle on-off switch.

x. *Carrier Heater Controls* (C, fig. 14). (Winterized Units Only). The winterized crane-shovel units have two gas-fired heaters, one for the engine and one for the cab and components. Both heater control boxes are mounted to the right and behind the operator. The control boxes are identical in operation. Each control box has three controls.

- (1) *Indicator light* (C, fig. 14). The function of the indicator light is to show when the heater is in operation. It is located on the left side of the control panel. The lamp glows constantly when the heater is on either high-fire or low-fire operation. It will glow when the heater has just been shut off for approximately two minutes until the heater starts to cool. The indicator light may be used as a check on the power

supply to the heater. A spring loaded terminal on the light socket is connected to the circuit breaker so that the lamp will light when pressed in if the circuit breaker is in, and power is available.

- (2) *Circuit breaker* (C, fig. 14). The circuit breaker is the center button of the heater control box. It is a safety device installed in the system to prevent current overloads from causing a fire hazard. To reset after tripping, press in the circuit breaker button.

**Caution:**

**Pulling out on the circuit breaker button breaks all electrical circuits to the heater. Do not attempt to stop heater operation with the circuit breaker. Stopping heater operation with the circuit breaker prevents the heater from purging itself at the end of the operating cycle.**

- (3) *Control switch* (C, fig. 14). The control switch is located on the right side of the heater control panel. It is a three-position toggle-type switch with ON-HI (up), OFF (center), and ON-LO (down) used to select the desired heater range.

y. *Heat Control Levers* (C, fig. 14). The heat control levers mounted in the duct located below the heat control boxes. They provide control of the heat to various ducts and have four position settings from open to closed.

z. *Radiator Shutter Control Lever* (D, fig. 14). The radiator shutter control lever is mounted on the radiator shutter. It has three positions open, half, and closed.

aa. *Overspeed Governor Reset Button*. The overspeed governor reset button, located on top of the overspeed governor, is a push type button. It is used to reset the overspeed button.

**Note.**

**Should overspeed occur, the governor will stop the engine and it cannot be restarted until the RESET BUTTON on the overspeed governor is pushed to reset it.**

## Section IV. OPERATION UNDER USUAL CONDITIONS

### 16. General

a. The instructions in this section are published for personnel responsible for operation of the crane.

b. The operator must know how to perform every operation of which the crane is capable. This section gives instructions on starting and stopping the crane, basic motions of the crane, and instructions on coordinating the basic motions to perform the specific tasks for which the equipment is designed. Since nearly every job presents a different problem, the operators may have to vary given procedures to fit the individual job.

### 17. Starting

#### a. Preparation for Starting the Carrier Engine.

- (1) Perform the necessary daily preventive maintenance services (para. 39).
- (2) Lubricate the carrier engine as specified in Lubrication Order, LO 5-3810-227-15 (fig. 17).

#### b. Starting the Carrier Engine.

- (1) Set the handbrake (fig. 13).

#### Caution:

**When operating the carrier, be sure to drive slowly when traveling over rough terrain, and avoid stopping suddenly. This will minimize carrier front spring failures.**

- (2) Depress clutch pedal and put gearshift lever in neutral position as shown on shifting diagram (fig. 13).
- (3) Keep clutch pedal depressed while cranking motor.
- (4) Turn ignition switch to ON position.
- (5) Pull choke control all the way out.
- (6) Press the accelerator pedal half way down, and press starter button; release starter button as soon as engine starts.
- (7) After engine starts, push choke control in until the engine runs smoothly.
- (8) Release clutch pedal slowly.
- (9) Check all gages for normal operation (fig. 13).

#### c. Preparation for Starting the Crane Engine.

- (1) Perform the necessary daily preventive maintenance services (para. 38).
- (2) Lubricate the crane engine as specified in LO 5-3810-227-16.

#### d. Starting the Crane Engine.

- (1) Disengage engine clutch lever by pushing forward (fig. 14).
- (2) Make sure drum safety pawl lever is in the locked position.
- (3) Place the throttle control lever in FAST IDLE position.
- (4) Pull choke control all the way out.
- (5) Turn the ignition switch to ON position, and push in on the starter button.
- (6) As soon as the engine starts, release starter button and adjust throttle control and choke until engine runs smoothly.
- (7) Check all gages for normal operation (fig. 14).

#### Caution:

**Should the oil gage indicate a pressure below 7 pounds at 400 to 600 rpm idling speed or greater than 60 pounds at operating speed, stop the engine immediately and investigate the trouble.**

### 18. Stopping

#### a. Stopping the Carrier Engine.

- (1) Reduce the speed of the engine by letting up on accelerator pedal (fig. 13).
- (2) Let engine idle for approximately 5 minutes to allow the engine block and manifold to cool.
- (3) Stop the engine by turning the ignition switch to the OFF position.
- (4) Perform the necessary daily preventive maintenance services (para. 38).

#### b. Stopping the Crane Engine.

- (1) Push the throttle control lever (fig. 14) to the CLOSED position and reduce the engine speed to idle for approximately 5

minutes to allow the engine block and manifold to cool.

- (2) Stop the engine by turning the ignition switch to the OFF position.
- (3) Make sure all controls are in the neutral position.
- (4) Perform the necessary daily preventive maintenance services (para. 38).

## 19. Carrier Operation

### a. Driving Carrier.

- (1) Perform the necessary daily preventive maintenance services (para. 38).
- (2) Place air line service shutoff valve located on front end of the carrier, in OPEN position.

#### **Note.**

**The air line service and emergency shutoff valves are marked on both front and rear of carrier.**

#### **Caution:**

**The air line service shutoff valve must be in OPEN position to prevent build up in the brake system resulting in setting of the brakes.**

- (3) Place air line emergency shutoff valve, located on front end of the carrier, in CLOSED position.

#### **Caution:**

**The air line emergency shutoff valve must be in CLOSED position to prevent emptying the entire air system.**

- (4) The air line service and emergency shutoff valves, located on rear end of the carrier, must be in CLOSED position.
- (5) Start the carrier engine (para. 17).
- (6) Refer to figure 13 and operate the carrier as instructed in b and c below.

### b. Forward Motion.

- (1) Depress clutch pedal.
- (2) Move transfer shift level into desired range; refer to shifting diagram.
- (3) Move the gearshift level into first speed shown on shifting diagram.
- (4) Push handbrake down.
- (5) Release clutch pedal slowly; at same time put pressure on accelerator pedal necessary for the engine to overcome the load and put carrier in motion.

- (6) As carrier gains speed, release pressure on accelerator pedal and press clutch pedal down. At same time move gearshift level through neutral and into next higher gear position, 2d.

- (7) Push down on accelerator pedal and release clutch pedal as before.

- (8) Repeat these operations until transmission is in its highest gear suitable for the condition.

### c. Reverse Motion.

- (1) Release pressure on accelerator pedal.
- (2) Depress clutch pedal and hold down; at same time apply pressure on brake pedal.
- (3) Stop carrier.
- (4) With clutch pedal depressed, move gearshift lever through neutral to the right rear in reverse position.
- (5) Release clutch pedal slowly; at the same time accelerate the engine in same manner as when moving the carrier forward. Look in intended direction of travel.
- (6) Stop the motion of the carrier as instructed in (1) through (8) above.
- (7) Disengage clutch pedal and put gearshift lever in neutral position; apply the handbrake.

#### **Note.**

**Quick application of the brakes may cause damage or injury.**

## 20. Crane Operation

a. *General.* The crane is used primarily for raising and lowering heavy loads. It is capable of operating through a wide range of conditions. Refer to paragraph 4 and tables 1 and 2.

b. *Positioning the Carrier.* Back the carrier up to the working site so that the major portion of the work will be performed off the rear of the carrier. Dumping or unloading should be done off the sides. Set the carrier airbrake lock after the working position is selected.

#### **Caution:**

**When the crane is being operated, the main transmission gearshift lever on carrier should be moved to neutral position and the handbrake set.**

### c. Boom Raising and Lowering.

- (1) Start the engine (para. 17).
- (2) Engage the engine clutch by pulling the engine clutch lever (fig. 14) back.

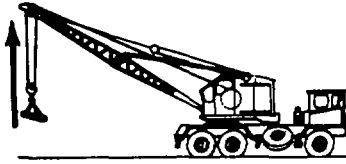

**HOISTING**  
 PULL R.H. DRUM CLUTCH LEVER AND AT THE SAME TIME RELEASE R.H. DRUM BRAKE PEDAL. AFTER LOAD IS LIFTED TO DESIRED HEIGHT APPLY R.H. DRUM BRAKE AND AT SAME TIME PUSH THE R.H. DRUM CLUTCH LEVER TO THE NEUTRAL POSITION.

**WARNING**  
 NEVER LEAVE THE CRANE WITH A LOAD IN THE RAISED POSITION. THE BRAKES MAY LOOSEN ENOUGH TO PERMIT THE LOAD TO FALL.

**LOWERING THE LOAD**

PUSH POWER LOAD LOWERING CLUTCH LEVER FORWARD AND AT THE SAME TIME RELEASE R.H. BRAKE PEDAL. CONTROL SPEED OF DESCENT BY SPEED OF ENGINE. TO STOP DESCENT, APPLY R.H. BRAKE PEDAL AND ALLOW POWER LOAD LOWERING LEVER TO RETURN TO NEUTRAL POSITION.

ALTERNATE METHOD: DISENGAGE BOOM HOIST JAW CLUTCH. ENGAGE HOIST CLUTCH AND DISENGAGE ENGINE CLUTCH. SLOWLY RELEASE FOOT BRAKE AND LOAD WILL LOWER OF ITS OWN ACCORD WHILE RUNNING MACHINERY BACKWARDS. THE INTERLOCK WILL PREVENT RELEASING THE BOOM HOIST JAW CLUTCH AND BRAKE AT THE SAME TIME.

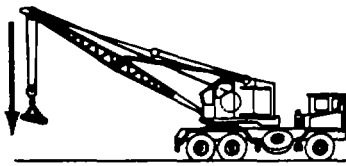

**SWINGING**

PUSH THE SWING CLUTCH LEVER TO SWING TO THE LEFT, PULL TO GO TO THE RIGHT, WHEN THE LOAD HAS REACHED THE DESIRED POSITION, MOVE THE SWING CLUTCH LEVER TO THE NEUTRAL POSITION. TO STOP SWING ENGAGE CLUTCH LIGHTLY IN OPPOSITE DIRECTION, OR APPLY SWING BRAKE WHEEL.

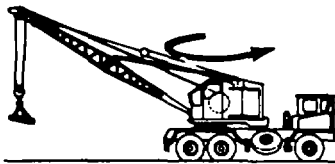

**RAISING OR LOWERING THE BOOM**

BE SURE JAW CLUTCH IS ENGAGED. TO RAISE BOOM, PULL BOOM HOIST LEVER BACK. WHEN BOOM REACHES DESIRED HEIGHT, RETURN BOOM HOIST LEVER TO NEUTRAL POSITION TO LOWER THE BOOM, DISENGAGE SAFETY PAWL LEVER BY PUSHING IT FORWARD, THEN PUSH BOOM HOIST LEVER FORWARD, WHEN BOOM REACHES DESIRED POSITION, RETURN BOOM HOIST LEVER TO NEUTRAL POSITION AND RESET SAFETY PAWL BY PULLING ITS LEVER TO THE REAR.

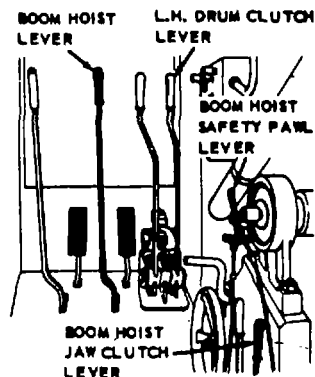
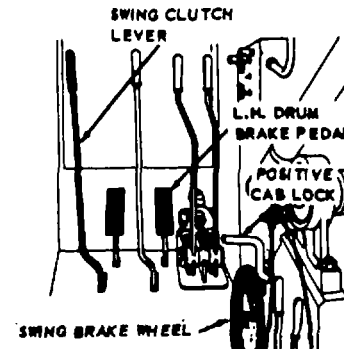
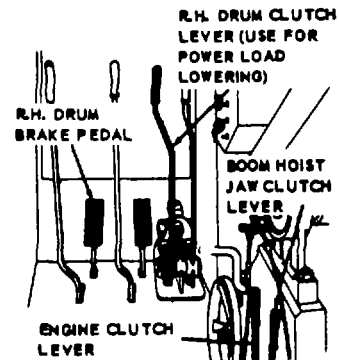
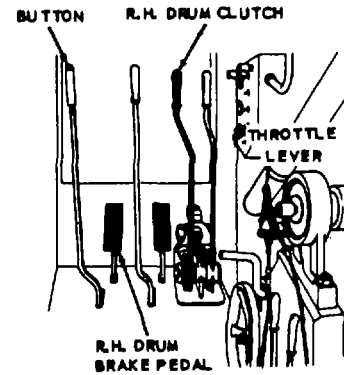
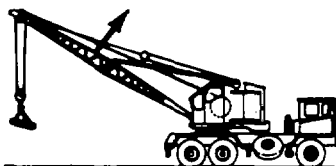

MEC 3820-227-15/15

Figure 15. Operations and control positions.



#### DRAGLINE OPERATION

Dragline operation requires a hoisting and an inhaul cable. The inhaul cable is on the R.H. drum. The hoisting cable is on the L.H. drum.

Lift the bucket by engaging the L.H. clutch lever and releasing L.H. brake and at the same time releasing R.H. brake pedal to allow bucket to swing out under the boom point as it is being lifted. After bucket is in desired position, set both brakes and disengage L.H. clutch.

To drop bucket for digging, release the L.H. brake. To dig with the bucket, engage the R.H. clutch and release the R.H. brake as the bucket is being pulled toward the machine. It will not fill unless additional cable is released from L.H. drum. This is accomplished by releasing L.H. brake.

When bucket is filled, disengage R.H. clutch while setting R.H. brake. Engage L.H. clutch and release L.H. brake to hoist bucket from the cut to the raise bucket to the dumping position. However, too much slack will allow bucket to dump early. To dump bucket completely, release R.H. brake pedal.

#### CLAMSHELL OPERATION

To raise bucket, engage both R.H. and L.H. clutch levers and simultaneously release R.H. and L.H. brake pedals.

When bucket reaches desired position, set R.H. and L.H. brake pedals while disengaging clutches at the same time.

To open and lower bucket, release R.H. brake pedal for opening. As the bucket is opening, release L.H. brake pedal for lowering. The rate of opening and lowering of bucket is controlled by pressure applied to brake pedals.

After the bucket has been set in the ground, engage R.H. drum clutch. This will close bucket. If additional cable is not let out from L.H. drum the bucket will raise as it closes. After bucket has closed, engage L.H. drum clutch to raise. When bucket has raised to desired height, set both brakes and at the same time, disengage both clutches.

To open bucket release L.H. brake pedal.

#### BACKHOE OPERATION

Backhoe operation requires a hoisting and an inhaul cable. The inhaul cable is on the R.H. drum and the hoist cable is on the L.H. drum.

To raise backhoe boom, engage the L.H. clutch and release L.H. foot pedal. This will raise the attachment to the desired height. To get the bucket in the desired digging position may require inward or outward spotting of the bucket.

The outward motion is accomplished by gently releasing the L.H. brake pedal. The bucket can be stopped at the desired position by resetting the L.H. brake.

The inward motion can be accomplished by releasing the R.H. brake pedal and engaging the R.H. clutch. This motion can be stopped at desired position by setting R.H. brake and disengaging R.H. clutch.

To lower the bucket into the cut, release the R.H. brake cautiously until the bucket reaches the ground. Engage R.H. clutch and release R.H. brake. This will pull the bucket toward the machine, filling it. As the bucket is being pulled toward the machine, additional cable must be released by slipping of the R.H. brake. When the bucket is filled or the extent of the travel has been reached, set the R.H. and disengage the R.H. clutch.

To hoist the bucket from the cut, engage L.H. clutch and release L.H. brake. When required height is reached dump the bucket by gently releasing the R.H. brake. When bucket is empty, reset L.H. and R.H. brake pedals and at the same time return L.H. clutch lever to neutral position.

#### SHOVEL OPERATION

Shovel operation requires hoist drum, crowd, and retract drum. Shovel operation requires the boom to be at a fixed recommended angle.

To get boom in fixed position pull boom hoist lever to the rear. After boom is at fixed angle, move boom hoist lever to neutral position.

To crowd shovel into bank, pull R.H. clutch lever back while releasing R.H. brake pedal. At the same time bucket is being crowded into the bank, bucket should be hoisted. This is accomplished by engaging L.H. clutch lever and at the same time disengaging L.H. brake pedal.

When bucket has reached desired height, return clutch levers to neutral position and set the brake pedals. To spot the bucket for dumping, it will probably be necessary to retract the bucket. This is accomplished by engaging R.H. clutch and disengaging R.H. brake. When bucket is spotted, set the R.H. brake and return R.H. clutch lever to neutral position.

When retracting bucket, and the load is higher than the stick pivot point, it will only be necessary to gently release the brake. When the bucket has been spotted, set the brake and dump the bucket by pushing button on dash panel. To close bucket, gently drop bucket by releasing L.H. brake pedal.

#### JIB OPERATION

To raise load, pull L.H. drum clutch lever and at the same time release L.H. brake pedal. When load has reached desired position, set L.H. brake pedal and return L.H. clutch lever to neutral position.

To lower the load, gently release L.H. brake pedal. When load is at desired position, reset brake pedal.

#### PILE DRIVER OPERATION

The pile driver attachment is suspended from the boom point by adapter leads. This is raised and lowered by normal boom hoist operation. The L.H. drum is used for raising the pile hammer.

To raise the hammer, engage L.H. clutch and disengage L.H. brake pedal. When hammer has been raised to desired height it is dropped. This is accomplished by returning L.H. clutch to neutral. Rate of drop is controlled by L.H. brake pedal.

The R.H. drum is used for handling piling or any other requirement in usual manner.

### Figure 15 - Continued.

- (3) To raise the boom, engage boom hoist jaw clutch, then engage the boom hoist safety pawl by pulling the boom hoist safety pawl lever back.
- (4) Pull the boom hoist lever towards the rear of the cab to raise the boom. When the boom has obtained the desired height, push the boom hoist lever to the neutral-position.
- (5) To lower the boom, raise it slightly as instructed above and push the safety pawl lever forward to release the safety pawl on the boom hoist drum. Push the boom hoist lever forward to lower the boom.
- (6) When the boom has obtained the desired height, pull the boom hoist lever back to the neutral position and engage the safety pawl by pulling the safety pawl lever back.
- (7) Operate the crane as instructed in figure 15.
- (8) Spotting the load requires accurate control of the hoist and swing movements to locate the load at the exact spot without hunting or overshooting. In event that it is necessary to relocate the carrier, be sure that the swing lock lever is engaged. Practice with the crane controls will soon enable the

operator to quickly and accurately pick up a load, raise and swing it into position, and correctly place it where desired.

- (9) Lower the load to the ground.
- (10) Engage the cab lock with the cab lock lever (fig. 14).
- (11) Place the boom hoist safety pawl lever in the engaged position by pulling backward.
- (12) Disengage the engine clutch by pushing forward.
- (13) Stop the crane engine (para. 18).

#### **21. Moving Crane With Boom Installed**

- a. No dismantling for movement is necessary on the crane-shovel. Stow and secure all parts and equipment.

**Note.**

**Normally, the crane-shovel will be driven short distance to a new worksite.**

- b. For movement other than short distances, position the crane-shovel on a flatcar as illustrated in figure 4.

**Note.**

**When transporting the crane, keep the counterweight to the rear of the carrier and the boom in its rack.**

### **Section V. OPERATION UNDER UNUSUAL CONDITIONS**

**Note.**

**Instructions necessary for the proper functioning of the crane in extreme cold, heat, dusty or sandy area, under rainy or humid conditions, in saltwater areas, and at high altitudes are given in paragraphs 22 through 27.**

#### **22. Operation in Extreme Cold (Below 0° F.)**

*a. Cooling System.*

- (1) Inspect the cooling system for leaks. Make sure all clamps are tight and draincocks are closed. Protect the cooling system from freezing by adding the amounts of approved ethyleneglycol type antifreeze; procure the required antifreeze through organizational maintenance and fill radiator.
- (2) Keep the radiator shutters adjusted to maintain normal coolant temperature.

*b. Lubrication*

- (1) Refer to the Lubrication Order (LO 5-3810-227-15) for special lubricants to use below -109° F. The carrier and the crane are equipped with winterization heaters. The heaters should be operated to heat the engine oil to near operating temperature before engines are started.
- (2) Check the oil in all cases, frequently, as oil consumption may increase.
- (3) Change oil more frequently than usual because of contamination by dilution and sludge formation.

c. *Batteries.*

- (1) Keep batteries fully charged at all times.

**Caution:**

**Unless the engines are running or the batteries are immediately charged, do not add water in subzero temperatures.**

- (2) Keep all wiring connections and battery terminals tight and free from snow and ice.
- (3) In extremely low temperatures, remove the batteries and place in a heated shelter when not in use.

d. *Fuel System.* Fuel tanks should be kept as full as possible at all times to minimize condensation. If presence of water is noted in the fuel supply, drain and refill with clean fuel. Drain and service fuel filters and strainers frequently (para. 88 and 95).

e. *Brakes.*

- (1) Do not allow the carrier to stand in mud or water overnight during subzero weather. Position the unit on wood planks.
- (2) To prevent brakes from freezing, they should not be applied when the vehicle is parked. Block the wheels to keep the machine from rolling.

f. *Controls and Instruments.* Due to congealing properties of the lubricants in cold weather, operation of controls may be sluggish when first used. Do not force levers in an attempt to put them in operation. Allow the engine to warm up slowly, this will allow the lubricants to thin.

g. *Precautions When Operating on Snow or Ice.* Take necessary steps to insure a firm footing for the crane. Extend outriggers and use blocking under jack pads to obtain firm footing.

## 23. Operation in Extreme Heat

a. *Cooling System.*

- (1) Make sure the system is clean and following.
- (2) Keep the coolant level in the radiator as high as possible.
- (3) Keep the water pump and its drive well lubricated (LO 5-3810-227-15).

- (4) Keep the fan belt adjusted properly. Be sure there is no obstruction of air to the fan.
- (5) Keep the radiator fins free of insects, leaves, dirt, and other obstructions.
- (6) Drain the cooling system by opening the draincocks on the radiator and the engine block. Flush out system with clean water. Do not use salt or mineral-water solutions in system.
- (7) If the engine continues to overheat, report the condition to organizational maintenance.

b. *Electrical System.*

- (1) Inspect the wiring for loose connections or deteriorated covering.
- (2) Never allow batteries to overheat in service. Guard against this by opening the battery box and allowing air to circulate around the batteries.
- (3) Add water to batteries to keep level of the electrolyte one-quarter inch above the plates.

c. *Lubrication.* Lubricate the crane and carrier with the proper lubricant in accordance with Lubrication Order (LO 5-3810-227-15).

d. *Engines.*

- (1) Use only the lubricants recommended in the current Lubrication Order (LO 5-3810-227-15).
- (2) Open all sliding panels in the cab to provide as much ventilation for the engines as possible. Also keep radiator shutters open.
- (3) Keep the engine clean. Accumulation of dust and oil form an insulation against cooling air from the fan.

## 24. Operation in Dusty or Sandy Areas

a. *Protection.* Keep the unit clean and clear of sand or dust, as the sand has the tendency to penetrate into the bearings and bushings. Because of this, the unit must be kept clean and be lubricated more frequently.

b. *Fuel Systems.* Keep fuel tank filler caps tight to prevent sand or dust from entering fuel tank. Service

AGO 6819A

fuel filters and screens frequently to keep them free of sand and grit.

*c. Lubrication.* Make sure that all lubrication fittings are clean and clear of sand or grit before lubricating. Lubricate in accordance with LO 5-3810-227-15.

*d. Revolving Frame Roller Path.* Operating under extreme sandy or dusty conditions will require frequent inspections of the revolving frame roller path. Never allow lubricant to collect on the roller path, as it will collect sand and cause rollers to wear excessively or slide on roller path.

*e. Clutches and Brakes.* Inspect clutches and brakebands frequently and blow out or wipe off accumulations of sand and dirt. Failure to keep bands clean will result in worn bands, scored drums and unsatisfactory operation.

*f. Cables.* Keep all unused cables in boxes. Clean operating cables frequently to prevent excessive cable wear and to insure satisfactory operation.

*g. Open Gears and Chains.* After operation in dust or sand, blow loose grit out of machinery or wash lubricant and foreign matter from gears and chains, and apply new lubricant. Application of new lubricant is important to prevent wear and maintain satisfactory operation.

*h. Air Cleaners.* Service the air cleaners more often than under normal conditions.

## **25. Operation Under Rainy or Humid Conditions**

*a. General.* Prevention of rust and deterioration of electrical insulation in humid or rainy areas require constant exercise of preventive measures.

*b. Lubrication.* Inspect gear cases, crankcases, and lubrication fittings to see that no water has entered the gearcase or crankcase. If there is water at all in the gearcase or crankcase, drain and refill in accordance with LO 5-3810-227-15.

*c. Cooling System.*

- (1) Make sure the system is clean and free flowing.
- (2) Keep the coolant level in the radiator as high as possible.

- (3) Keep the water pump and its drive well lubricated.
- (4) Keep the fan belts adjusted properly.
- (5) Be sure there is no obstruction of air to the fan.
- (6) If the engines become overheated from lack of water, allow them to cool before adding water. Let the engines run at fast idle when adding water.

*d. Batteries.* Keep the batteries fully charged at all times.

*e. Fuel System.* Keep the fuel tank filler caps tight to prevent water from entering the fuel tank and fuel containers. Service the fuel tanks frequently to prevent condensation in the tank and lines.

*f. Electrical System*

- (1) Inspect the wiring for loose connections or deteriorated covering.
- (2) Frequent inspection is necessary to find worn spots in the insulation which, unless repaired, allow short circuit conditions.

## **26. Operation in Salt-Water Areas**

*a. General.* Prevention of rust and deterioration of electrical insulation in salt-water areas requires constant exercise of preventive measures. Although the wiring on the crane-shovel and carrier has been specially treated to resist fungus and rot, frequent inspection is necessary.

*b. Protection.* Inspect the unit for rust and corrosion. Rust and corroded conditions at any point on the unit must be corrected immediately. Remove all rust, and paint the bare surfaces. Place a light film of lubricant on polished or machined metal surfaces.

### **Caution:**

**Use only clean fresh water when filling the radiator. Do not use salt or mineral water solutions in the system, except in an emergency.**

*c. Fuel Systems.* Keep fuel tank filler caps tight to prevent any salt water from entering the fuel tank and containers. Service the fuel filters and screens frequently.

d. *Electrical System.* Make sure that all electrical leads are in good condition and not frayed, and that insulation is not torn or broken. Repair any broken insulation as it may lead to a short in the electrical system.

e. *Batteries.* Check the batteries to make sure they are full of water, that all connections are tight, and that the terminals are greased to prevent any corrosion.

f. *Lubrication.* Keep parts thoroughly lubricated to prevent entry of water into bearings and polished metal surfaces. Keep lifting cables lubricated as specified in LO 5-3810-227-15.

## 27. Operation at High Altitude

Operation at high altitude presents operational problems due to lower atmospheric pressure and wide temperature ranges. At altitudes above 5,000 feet it is necessary to adjust carburetors (paras. 86 and 93). Be sure the air cleaner is clean and free of obstructions. Service the air cleaners frequently. Maximum performance can be maintained by carefully following the operator's daily preventative maintenance services (para. 38).

### Caution:

**Check the units frequently for overheating of the engines in high-altitude operation.**

## Section VI. OPERATION OF AUXILIARY MATERIEL USED IN CONJUNCTION WITH THE CARRIER AND CRANE

### 28. General

This section covers the description, operation, and maintenance of auxiliary equipment supplied for use with the carrier and crane but not necessary for the basic functioning of the carrier and crane.

### 29. Carrier Engine Heater (Winterized Units Only)

a. *Description.* The carrier engine heater (A, fig. 16) is mounted to the front crossmember just in front of the right front wheel. For cold-weather operation the gas-fired, liquid heater provides the carrier engine with sufficient heat to start normal function by heating and circulating the liquid coolant in the cooling system. The engine oil pan is also jacketed for heating by the liquid coolant. An electric pump circulates the coolant during the heating operation.

b. *Heater Operation* (B, fig. 16).

- (1) Position control switch to ON-HI position.

#### Note.

**When heater has ignited and is operating satisfactorily the indicator lamp will glow.**

- (2) To stop heater, position the control switch to OFF position. The indicator lamp will remain on until heater has purged.

### 30. Carrier Cab Heater (Winterized Units Only)

a. *Description.* The carrier cab fresh air heater (C, fig. 16) is mounted to the rear of the carrier engine housing. For cold-weather operation the gas-fired fresh air heater provides the operator's cab and the battery box with heat.

b. *Operation.* Operate the carrier cab personnel heater in the same manner as the carrier engine heater (para. 29).

### 31. Crane Engine Heater

a. *Description.* The crane engine heater (O, fig. 16) is mounted under the floor of the revolving superstructure at the right rear corner below the engine speed reducer. For cold-weather operation the gas-fired liquid heater provides the crane engine with sufficient heat to start normal function by heating and circulating the liquid coolant in the cooling system. The engine oil pan is also jacketed for heating by the liquid coolant. An electric pump circulates the coolant during the heating operation.

b. *Heater Operation.* Operate the crane engine heater in the same manner as the carrier heater (para. 29).

### 32. Crane Cab Heater

a. *Description.* The crane cab fresh air heater (E, fig. 16) is mounted on the right side of the revolving

AGO 6819A

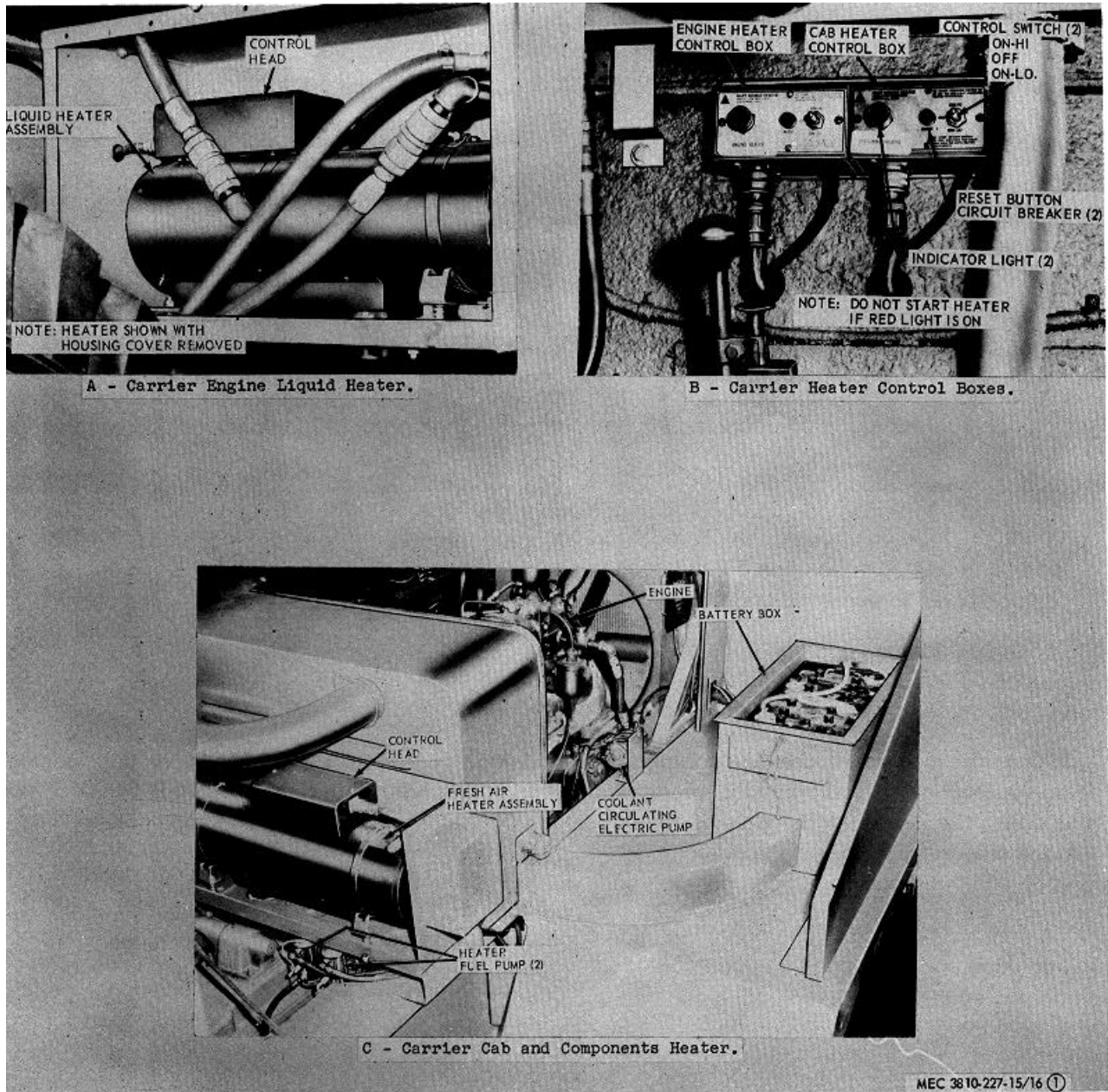

**Figure 16. Heaters and controls (winterized unit only).**

superstructure at about midpoint and has its own access door. For coldweather operation the gas-fired fresh air heater provides heat for the operator's cab, battery box, and heat box (under machine deck).

*b. Operation.* Operate the crane cab heater in the same manner as the carrier engine heater (para. 29).

### **33. Fire Extinguisher (Dry Chemical Type)**

*a. Description.* The dry chemical type fire extinguisher is suitable for use on all types of fire and is effective in areas where ambient temperature is -25° F. and above. If winterized, (pressurized with nitrogen) the fire extinguisher may be used in temperatures below -25° F. The fire extinguisher is a 2 1/2 pound, stored pressure, lever-operated extinguisher.

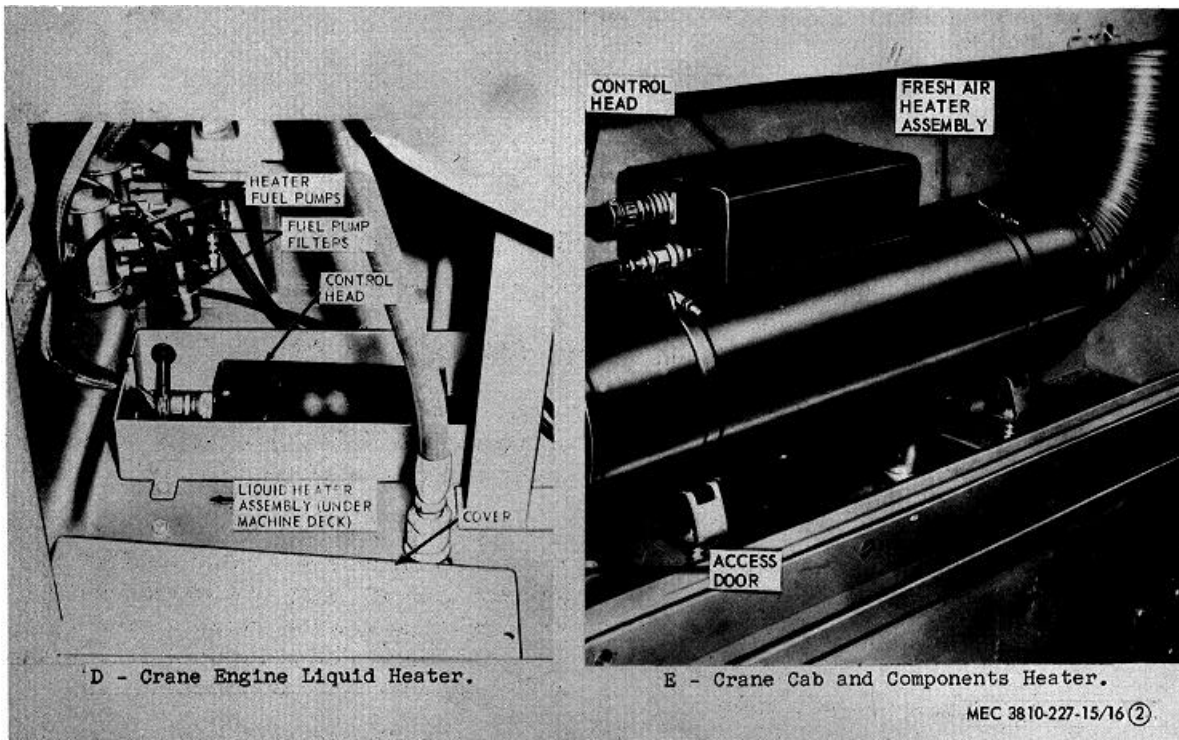

**Figure 16 - Continued.**

*b. Operation.* Remove the fire extinguisher from its location, lift the handle, press lever, and direct the power at the base of the flame using a side-to-side sweeping motion.

*c. Maintenance.* Weigh the fire extinguisher every 6 months and replace the extinguisher if weight is less

than 4 1/2 pounds, or if pressure is below 125 pounds. Refer to SB 5-111. The dry chemical fire extinguishers will be serviced at installation level through Repair and Utilities facilities, with the filling agent supplied by local procurement through Troop Supply Channels.

## CHAPTER 3

### OPERATOR AND CREW MAINTENANCE INSTRUCTIONS

---

#### Section I. SPECIAL TOOLS AND LUBRICANTS

#### 34. Tools and Equipment

No special tools or equipment is needed by the operator for the maintenance of this crane.

#### 35. General Lubrication Information

This section contains the lubrication order and lubrication instructions (fig. 17).

#### 36. Detailed Lubrication Information

*a. Care of Lubricants.* When storing or handling lubricants, make certain the containers are clean and securely covered to prevent dirt, dust, or foreign matter from entering. Be sure the lubricant is clean before using it.

*b. Cleaning.* Clean all surfaces surrounding the point to be lubricated before applying the lubricant. Use a clean cloth dampened in an approved cleaning solvent to clean the surface before lubricating. Remove all excess lubricant after lubricating.

*c. Points of Application.* The points of application can be located by referring to the Lubrication Order (fig. 17) and to the detailed illustrations of the lubrication points. Follow the instructions and apply the lubricant prescribed.

**Caution:**

**Overlubrication may cause equipment failure or damage to working parts.**

*d. Lubrication Instruct for Unusual Conditions.* The intervals will be more frequent when operating the crane during extremely high temperatures, in dust or sand, or under any conditions which tends to destroy the protective quality of the lubricant.

*e. OES Oil.* The crankcase oil level must be checked frequently as oil consumption may increase. This oil may require changing more frequently than usual because contamination by dilution and sludge formation will increase under cold-weather conditions.

*f. Carrier Engine Oil Filter Service.* Service the carrier oil filter as instructed in figure 18.

*g. Crane Engine Oil Filter Service.* Service the crane engine oil filter as instructed in figure 18.

*h. Carrier Engine Crankcase Breather Service.* Service the carrier engine crankcase breather as instructed in figure 19.

*i. Carrier Engine Air Cleaner Service.* Service the carrier engine air cleaner as instructed in figure 20.

*j. Crane Engine Crankcase Breather Service.* Service the crane engine crankcase breather as instructed in figure 19.

*k. Crane Engine Air Cleaner Service.* Service the crane engine air cleaner as instructed in figure 20.

*l. Carrier Engine Air Compressor Breather Service.* Service the air compressor breather as instructed in figure 21.





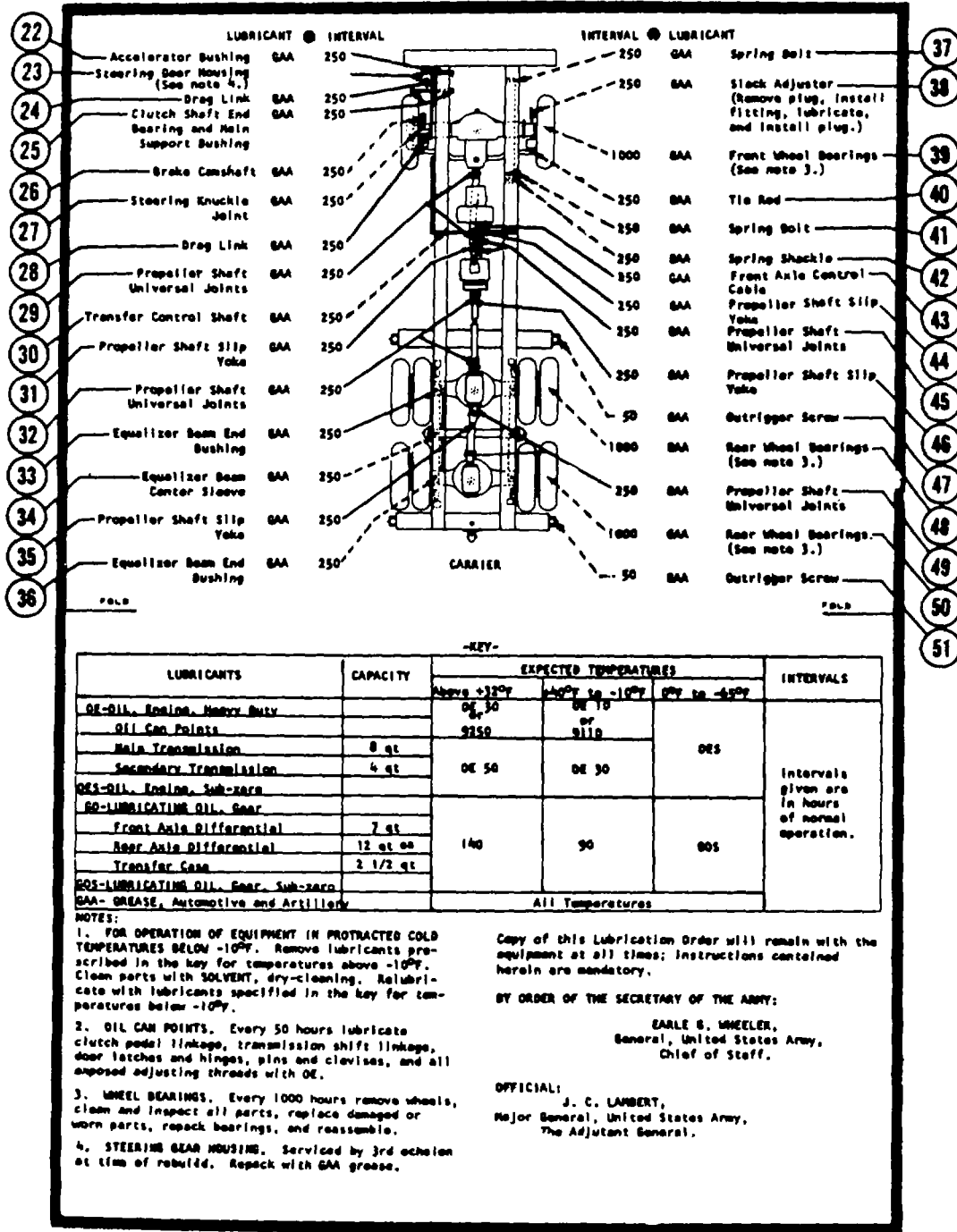

-KEY-

LUBRICANTS	CAPACITY	EXPECTED TEMPERATURES			INTERVALS
		Above +32°F	-10°F to +10°F	0°F to -45°F	
DE-OIL, Engine, Heavy Duty		DE 50	DE 15	OES	Intervals given are in hours of normal operation.
Oil Can Points		9750	or 3110		
Main Transmission	8 qt				
Secondary Transmission	4 qt	DE 50	DE 30		
OES-OIL, Engine, Sub-zero				OOS	
RS-LUBRICATING OIL, Gear					
Front Axle Differential	7 qt				
Rear Axle Differential	12 qt ea	140	90		
Transfer Case	2 1/2 qt				
GRS-LUBRICATING OIL, Gear, Sub-zero					
GAA- GREASE, Automotive and Artillery		All Temperatures			

NOTES:

- FOR OPERATION OF EQUIPMENT IN PROTRACTED COLD TEMPERATURES BELOW -10°F. Remove lubricants prescribed in the key for temperatures above -10°F. Clean parts with SOLVENT, dry-cleaning. Relubricate with lubricants specified in the key for temperatures below -10°F.
- OIL CAN POINTS. Every 50 hours lubricate clutch pedal linkage, transmission shift linkage, door latches and hinges, pins and clevises, and all exposed adjusting threads with OE.
- WHEEL BEARINGS. Every 1000 hours remove wheels, clean and inspect all parts, replace damaged or worn parts, repack bearings, and reassemble.
- STEERING GEAR HOUSING. Serviced by 3rd echelon at time of rebuild. Repack with GAA grease.

Copy of this Lubrication Order will remain with the equipment at all times; instructions contained herein are mandatory.

BY ORDER OF THE SECRETARY OF THE ARMY:

EARLE B. WHEELER,  
General, United States Army,  
Chief of Staff.

OFFICIAL:

J. C. LAMBERT,  
Major General, United States Army,  
The Adjutant General.

MEC 3810-227-15/17 (2)

Figure 17-Continued.

LUBRICATION  
ORDER

# LO5-3810-227-15-2

CRANE-SHOVEL, BASIC UNIT, TRUCK MOUNTED; 20 TON, 3/4

CU YO; GASOLINE ENGINE, 6 X 6 (AMERICAN HOIST &

BERRICK MODELS W-2360 (WINTERIZED) & 2360

(NON-WINTERIZED) W/CONTINENTAL ENGINE

MODELS 55749 (CARRIER) 55415 (CRANE)

Reference: LO 5-3810-227-15-1, -3, and -4 C9100-SL

Intervals are based on normal hours of operations. Reduce to compensate for abnormal operations and severe conditions. During inactive periods, sufficient lubrication must be performed for adequate preservation.

Clean fittings before lubricating.

Relubricate after washing or fording.

A dotted circle indicates a drain below.

Clean parts with SOLVENT, dry-cleaning, or with OIL, fuel, Diesel. Dry before lubricating.

Lubricate points indicated by dotted arrow shafts on both sides of equipment.

Drain gearcase when hot. Fill and check level.

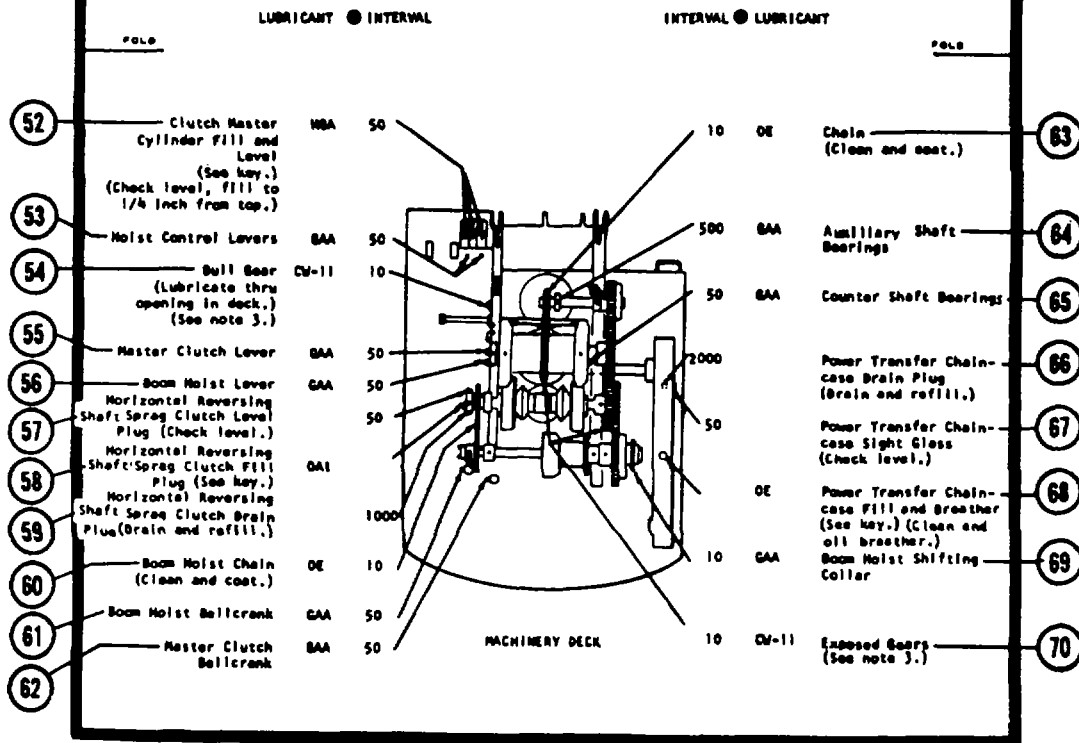

MEC 3810-227-15/17 (3)

Figure 17-Continued.



LUBRICATION  
ORDER

# LO 5-3810-227-15-3

CRANE-SHOVEL, BASIC UNIT, TRUCK MOUNTED: 20 TON, 3/4

CU YD; GASOLINE ENGINE, 6 X 6 (AMERICAN HOIST &

DERRICK MODELS W-2360 (WINTERIZED) & 2360

(NON-WINTERIZED) W/CONTINENTAL ENGINE

MODELS 55749 (CARRIER) 55415 (CRANE)

Reference: LO 5-3810-227-15-1, -2, and -4 C9100-SL

Intervals are based on normal hours of operations. Reduce to compensate for abnormal operations and severe conditions. During inactive periods, sufficient lubrication must be performed for adequate preservation.

Clean parts with SOLVENT, dry-cleaning, or with OIL, fuel, Diesel. Dry before lubricating.

Clean fittings before lubricating.

Lubricate points indicated by dotted arrow shafts on both sides of equipment.

Relubricate after washing or fording.

FOLD

FOLD

LUBRICANT ● INTERVAL

INTERVAL ● LUBRICANT

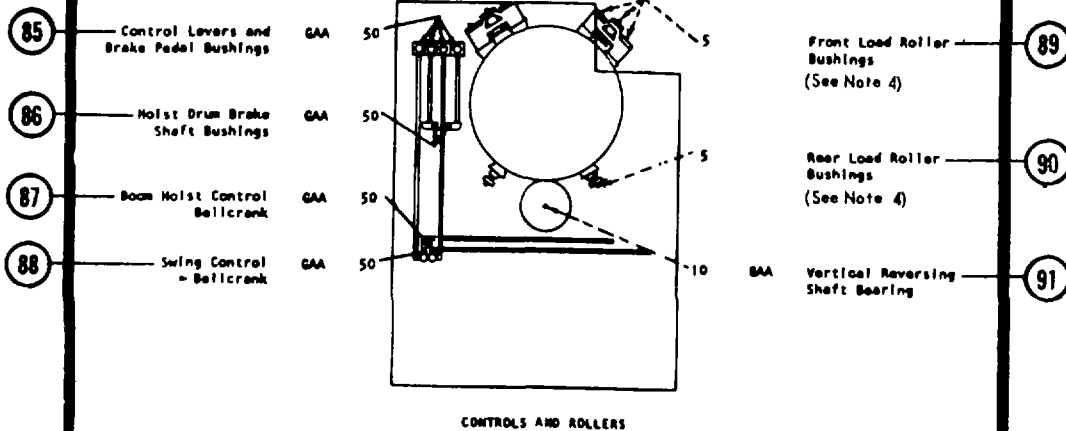

MEC 3810-227-15/17 (5)

Figure 17-Continued.

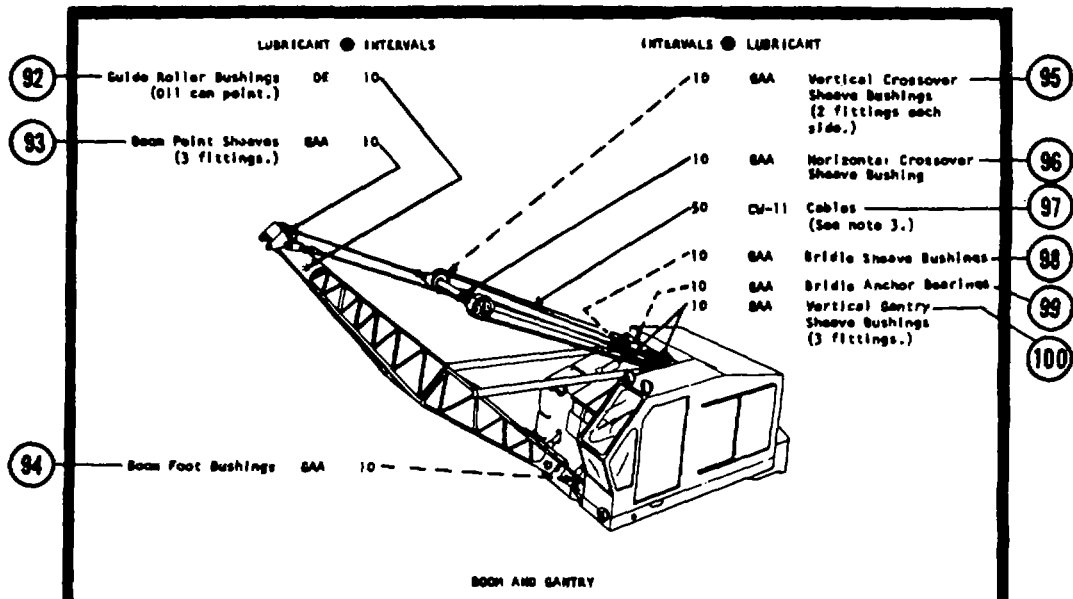

BOOM AND GANTRY

FOLO

-KEY-

LUBRICANTS	CAPACITY	EXPECTED TEMPERATURES			INTERVALS
		Above +32°F	+30°F to -10°F	10°F to -65°F	
DE-OIL, Engine, Heavy Duty		DE 30	DE 10		Intervals given are in hours of normal operation.
Oil Can Points		or	or	OES	
OES-OIL, Engine, Sub-zero		9250	9110		
CV-11-LUBRICATING OIL, Emulsed Base		All Temperatures			
GAA-GREASE, Automotive and Auxiliary					

- NOTES:
- FOR OPERATION OF EQUIPMENT IN PROTRACTED COLD TEMPERATURES BELOW -10°F. Remove lubricants prescribed in the key for temperatures above -10°F. Clean parts with SOLVENT, dry-cleaning. Relubricate with lubricants specified in the key for temperatures below -10°F.
  - OIL CAN POINTS. Every 50 hours lubricate control linkages, pins and clevises, and all exposed adjusting threads with DE.
  - CABLES. Every 50 hours clean and coat all cables with CV-11 except those coming in constant contact with dirt or excavated materials.
  - Load Rollers use Marlex<sup>TM</sup> Grease only
- Copy of this Lubrication Order will remain with the equipment at all times; instructions contained herein are mandatory.
- BY ORDER OF THE SECRETARY OF THE ARMY:  
 EARLE G. WHEELER,  
 General, United States Army,  
 Chief of Staff.
- OFFICIAL:  
 J. C. LAMBERT,  
 Major General, United States Army,  
 The Adjutant General.

MEC 3810-227-15/17 (6)

Figure 17-Continued.

LUBRICATION  
ORDER

# LO5-3810-227-15-4

CRANE-SHOVEL, BASIC UNIT, TRUCK MOUNTED: 20 TON, 3/4

CU YD; GASOLINE ENGINE, 6 X 6 (AMERICAN MOIST &

DERRICK MODELS W-2360 (WINTERIZED) & 2360

(NON-WINTERIZED) W/CONTINENTAL ENGINE

MODELS 55749 (CARRIER) 85415 (CRANE)

Reference: LO 5-3810-227-15-1, -2, and -3 CS100-BL

Intervals are based on normal hours of operations. Reduce to compensate for abnormal operations and severe conditions. During inactive periods, sufficient lubrication must be performed for adequate preservation.

Clean fittings before lubricating.

Relubricate after washing or fording.

A dotted circle indicates a drain below.

Clean parts with SOLVENT, dry-cleaning, or with OIL, fuel, Diesel. Dry before lubricating.

Lubricate points indicated by dotted arrow shafts on both sides of equipment.

Drain crankcases when hot. Fill and check level.

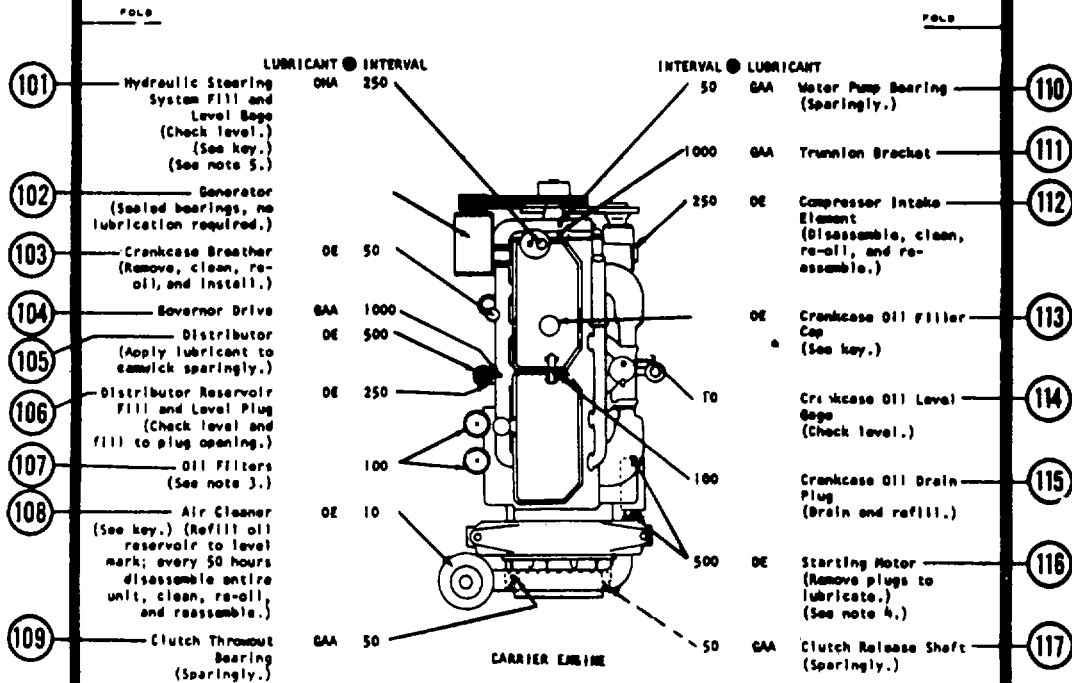

MEC 3810-227-15/17 ⑦

Figure 17-Continued.

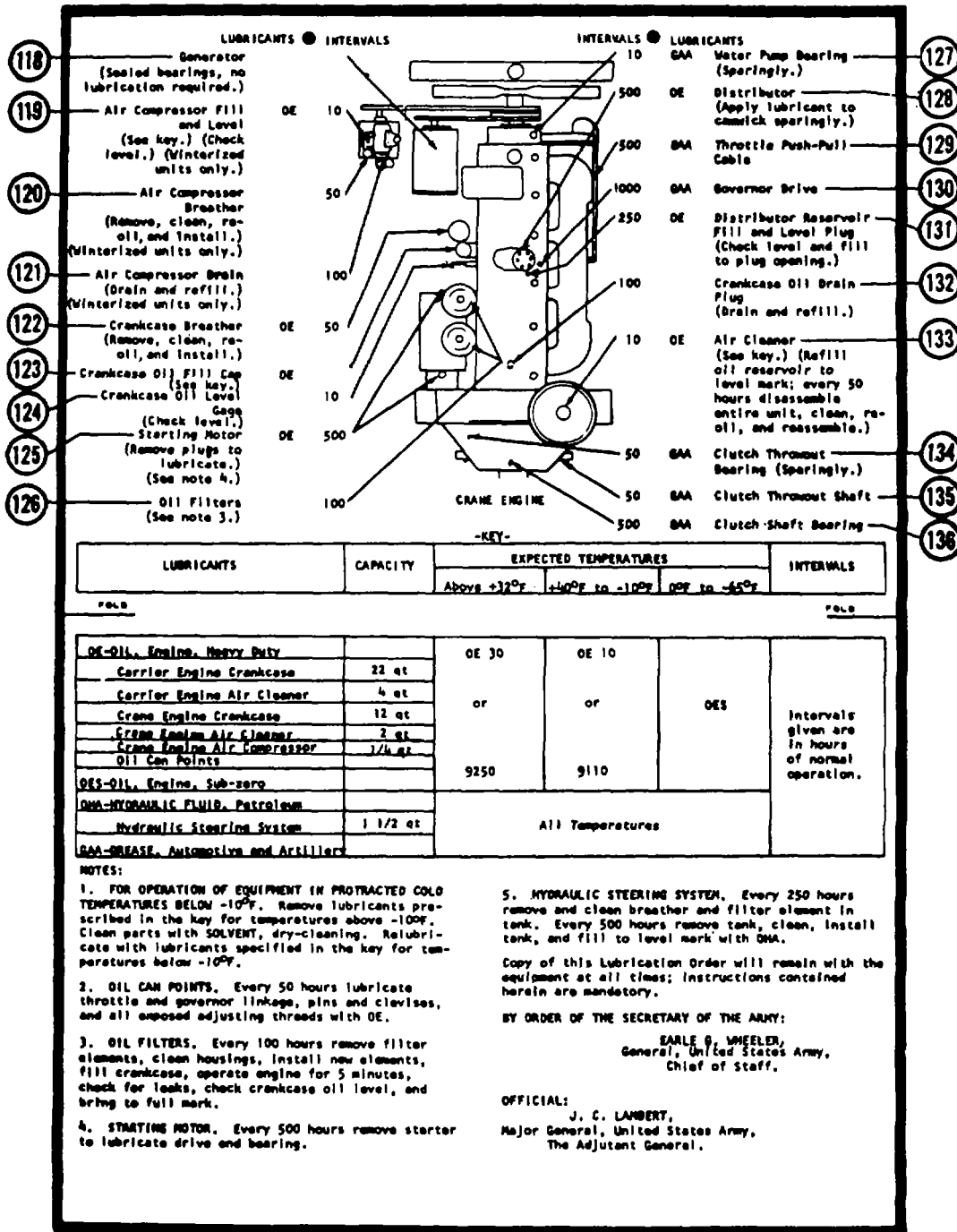

MEC 3810-227-15/17 (8)

Figure 17-Continued.



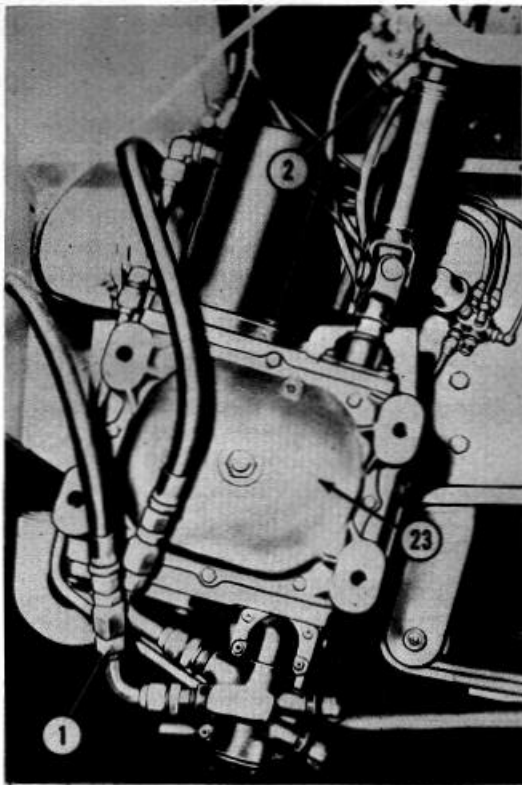

REF. 1. HYDRAULIC STEERING SYSTEM DRAIN  
 REF. 2. STEERING GEAR UNIVERSAL JOINTS  
 REF. 23. STEERING GEAR HOUSING

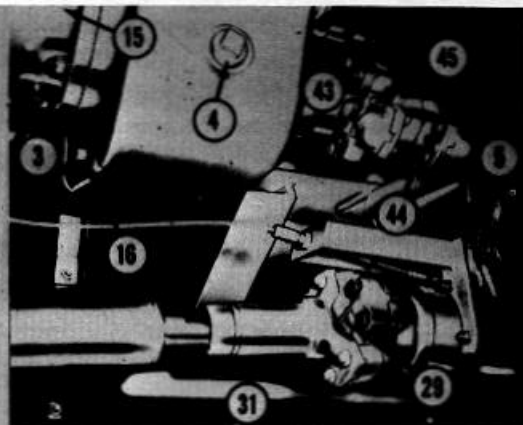

REF. 3. MAIN TRANSMISSION DRAIN PLUG  
 REF. 4. SECONDARY TRANSMISSION FILL AND LEVEL PLUG  
 REF. 5. TRANSFER CASE FILL PLUG  
 REF. 15. MAIN TRANSMISSION FILL AND LEVEL PLUG  
 REF. 16. SECONDARY TRANSMISSION DRAIN PLUG  
 REF. 29. PROPELLER SHAFT UNIVERSAL JOINTS  
 REF. 31. PROPELLER SHAFT SLIP YOKE  
 REF. 43. FRONT AXLE CONTROL CABLE  
 REF. 44. PROPELLER SHAFT SLIP YOKE  
 REF. 45. PROPELLER SHAFT UNIVERSAL JOINTS

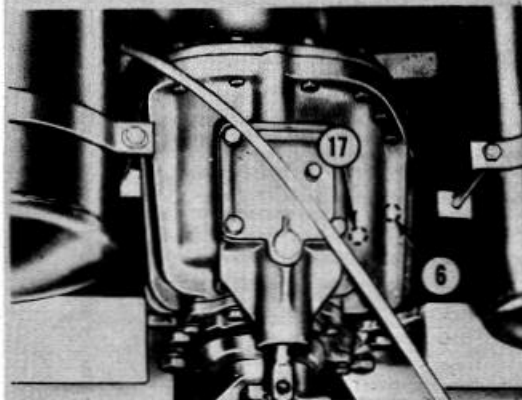

REF. 6. TRANSFER CASE LEVEL CAP  
 REF. 17. TRANSFER CASE DRAIN PLUG

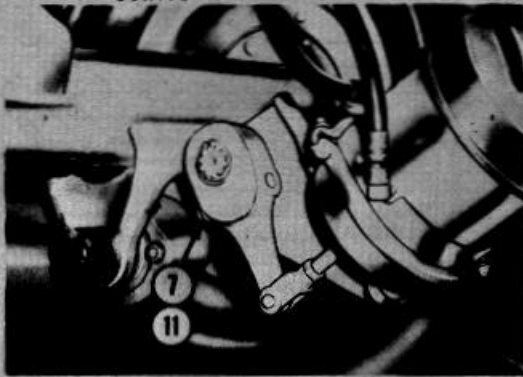

REF. 7. SLACK ADJUSTER  
 REF. 11. SLACK ADJUSTER

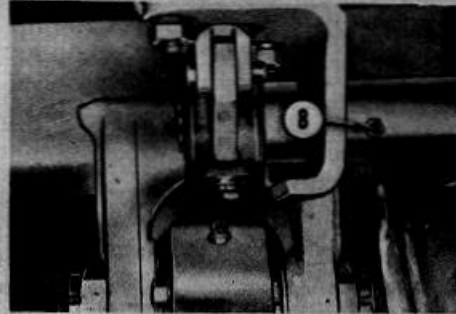

REF. 8. BRAKE CAMSHAFT

MEC 3810-227-15/17 9

Figure 17-Continued.

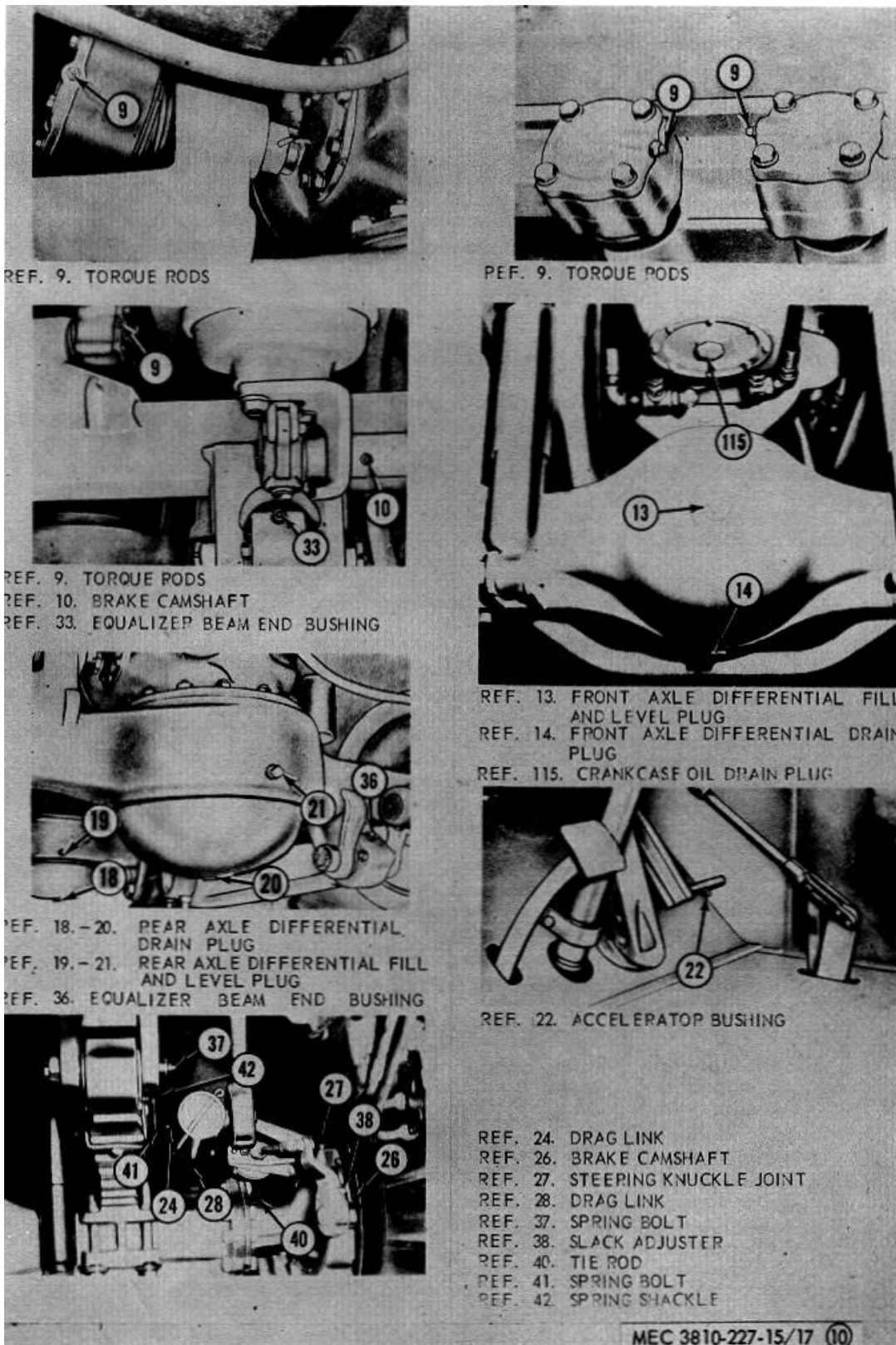
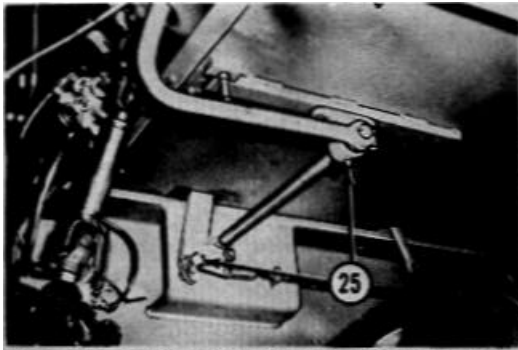
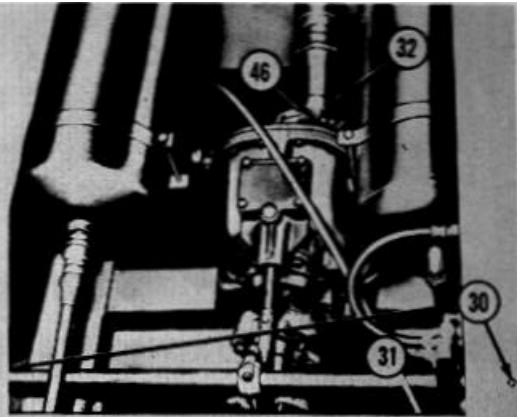

Figure 17-Continued.



REF. 25. CLUTCH SHAFT END BEARING AND MAIN SUPPORT BUSHING



REF. 30. TRANSFER CONTROL SHAFT  
REF. 31. PROPELLER SHAFT SLIP YOKE  
REF. 32. PROPELLER SHAFT UNIVERSAL JOINTS  
REF. 46. PROPELLER SHAFT SLIP YOKE

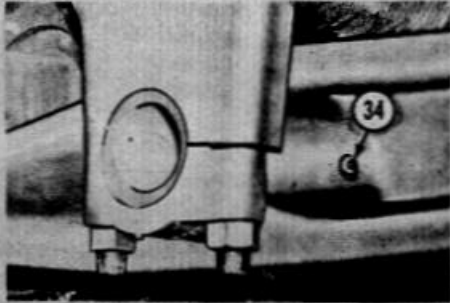

REF. 34. EQUALIZER BEAM CENTER SLEEVE



REF. 35. PROPELLER SHAFT SLIP YOKE  
REF. 49. PROPELLER SHAFT UNIVERSAL JOINTS

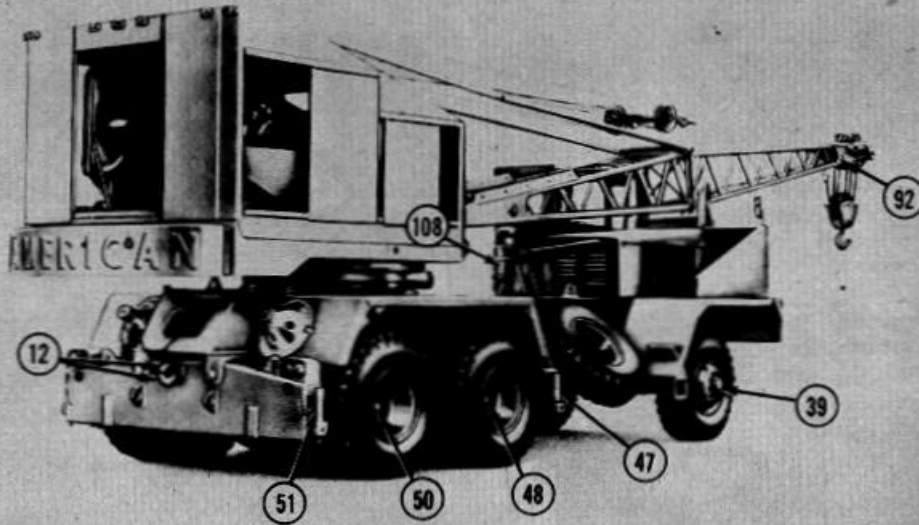

REF. 12. PINTLE  
REF. 39. FRONT WHEEL BEARINGS  
REF. 47. OUTRIGGER SCREW  
REF. 48. REAR WHEEL BEARINGS

REF. 50. REAR WHEEL BEARINGS  
REF. 51. OUTRIGGER SCREW  
REF. 92. GUIDE ROLLER BUSHINGS  
REF. 108. AIR CLEANER

MEC 3810-227-15/17 11

Figure 17-Continued.



REF. 52. CLUTCH MASTER CYLINDER FILL AND LEVEL\*

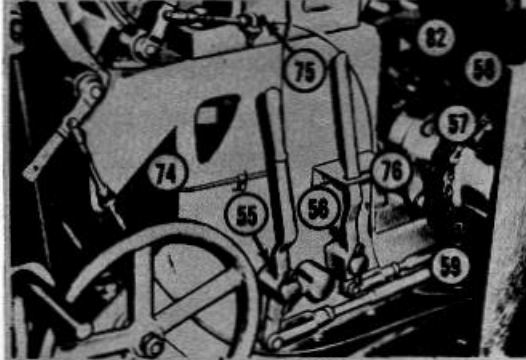

REF. 55. MASTER CLUTCH LEVER  
 REF. 56. BOOM HOIST LEVER HORIZONTAL REVERSING  
 REF. 57. SHAFT SPRAG CLUTCH LEVEL PLUG  
 REF. 58. HORIZONTAL REVERSING SHAFT SPRAG CLUTCH FILL PLUG  
 REF. 59. HORIZONTAL REVERSING SHAFT SPRAG CLUTCH DRAIN PLUG  
 REF. 74. THROTTLE PUSH-PULL CABLE  
 REF. 75. BOOM HOIST LOCK PUSH-PULL CABLE  
 REF. 76. HORIZONTAL REVERSING SHAFT BEARING  
 REF. 82. HORIZONTAL REVERSING SHAFT BEARINGS

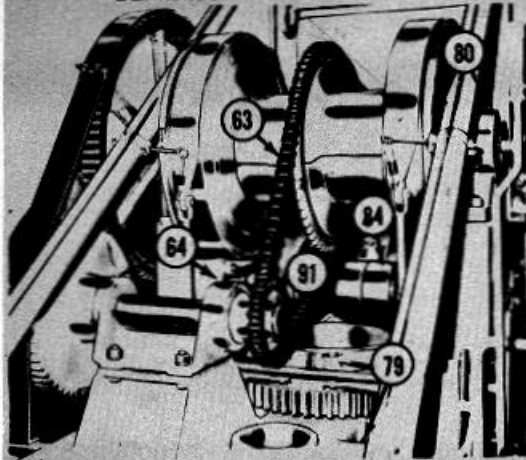

REF. 63. CHAIN  
 REF. 64. AUXILIARY SHAFT BEARINGS  
 REF. 79. HOIST DRUM BRAKE SHAFT BUSHINGS  
 REF. 80. HOIST DRUM SHAFT BEARINGS  
 REF. 84. HORIZONTAL REVERSING SHAFT BEVEL GEAR BEARINGS  
 REF. 91. VERTICAL REVERSING SHAFT BEAR-

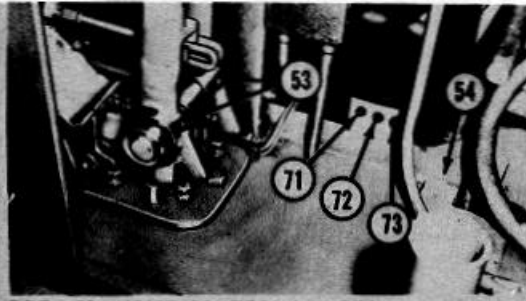

REF. 53. HOIST CONTROL LEVERS  
 REF. 54. BULL GEAR  
 REF. 71. VERTICAL SHAFT BUSHING  
 REF. 72. VERTICAL SWING SHAFT UPPER BUSHING  
 REF. 73. VERTICAL SWING SHAFT LOWER BUSHING

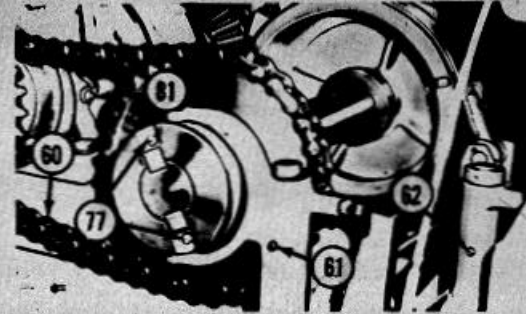

REF. 60. BOOM HOIST CHAIN  
 REF. 61. BOOM HOIST BELLCRANK  
 REF. 62. MASTER CLUTCH BELLCRANK  
 REF. 77. BOOM HOIST JAW CLUTCH  
 REF. 81. HORIZONTAL REVERSING SHAFT SHIFTING COLLARS

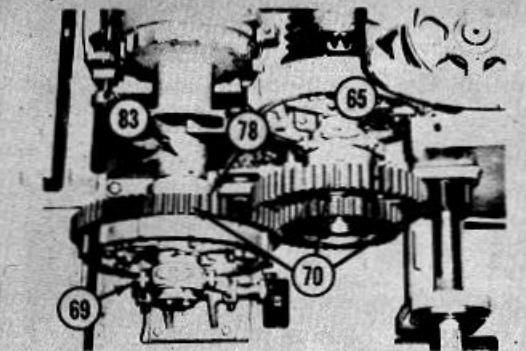

REF. 65. COUNTER SHAFT BEARINGS  
 REF. 69. BOOM HOIST SHIFTING COLLAR  
 REF. 70. EXPOSED GEARS  
 REF. 78. BOOM HOIST BEARINGS  
 REF. 83. BOOM HOIST GEAR BEARINGS

MEC 3810-227-15/17 12

Figure 17-Continued.

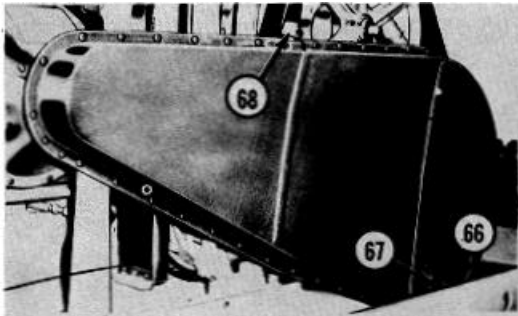

- REF. 66. POWER TRANSFER CHAINCASE DRAIN PLUG
- REF. 67. POWER TRANSFER CHAINCASE SIGHT GLASS
- REF. 68. POWER TRANSFER CHAINCASE FILL AND BREATHER

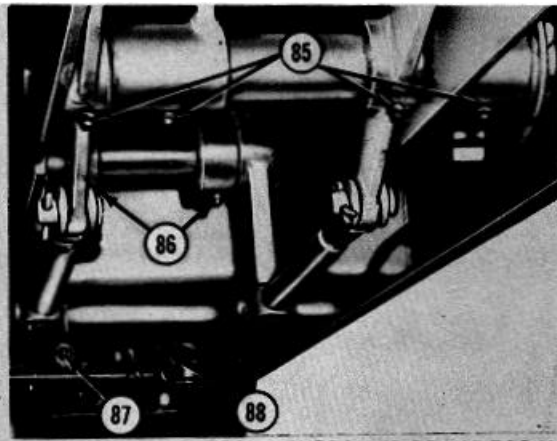

- REF. 85. CONTROL LEVERS AND BRAKE PEDAL BUSHINGS
- REF. 86. HOIST DRUM BRAKE SHAFT BUSHINGS
- REF. 87. BOOM HOIST CONTROL BELLCRANK
- REF. 88. SWING CONTROL BELLCRANK

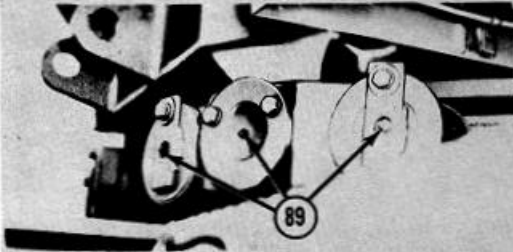

- REF. 89. FRONT LOAD ROLLER BUSHINGS

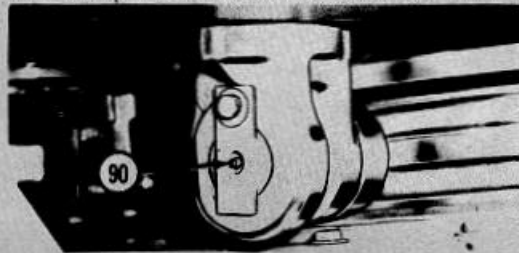

- REF. 90. REAR LOAD ROLLER BUSHINGS

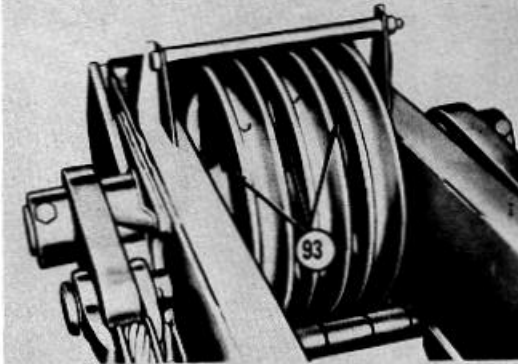

- REF. 93. BOOM POINT SHEAVES

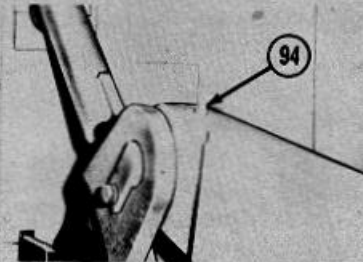

- REF. 94. BOOM FOOT BUSHINGS

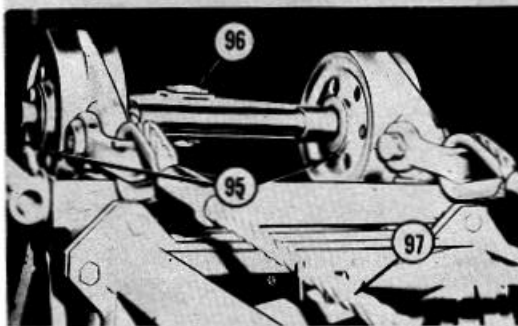

- REF. 95. VERTICAL CROSSOVER SHEAVE BUSHINGS
- REF. 96. HORIZONTAL CROSSOVER SHEAVE BUSHING
- REF. 97. CABLES

MEC 3810-227-15/17 (13)

Figure 17-Continued.

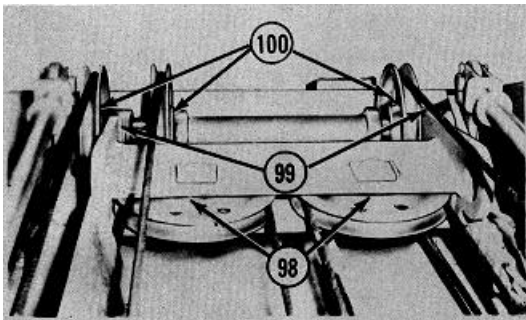

REF. 98. BRIDLE SHEAVE BUSHINGS  
 REF. 99. BRIDLE ANCHOR BEARINGS  
 REF. 100. VERTICAL GANTRY SHEAVE BUSHINGS

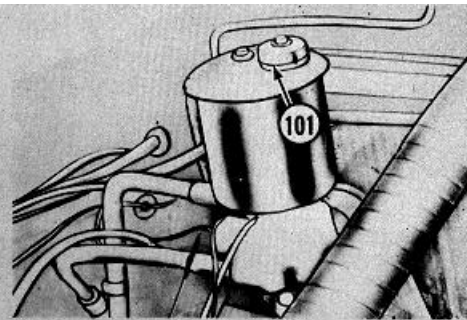

REF. 101. HYDRAULIC STEERING SYSTEM FILL AND LEVEL GAGE

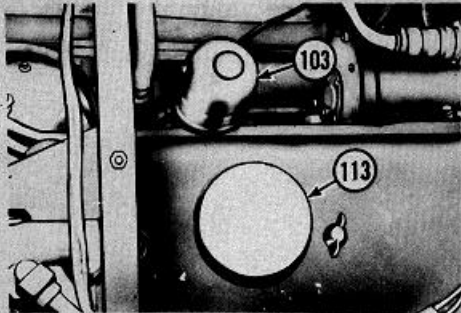

REF. 103. CRANKCASE BREATHER  
 REF. 113. CRANKCASE OIL FILLER CAP

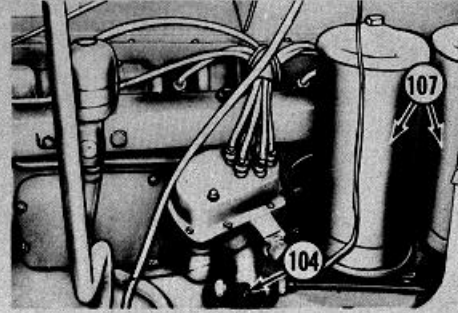

REF. 104. GOVERNOR DRIVE  
 REF. 107. OIL FILTERS

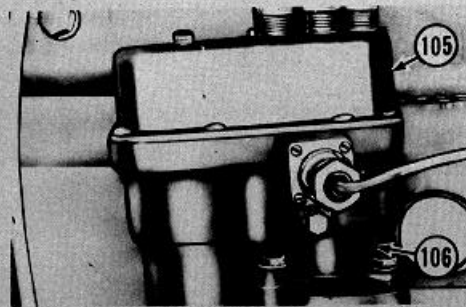

REF. 105. DISTRIBUTOR  
 REF. 106. DISTRIBUTOR RESERVOIR FILL AND LEVEL PLUG

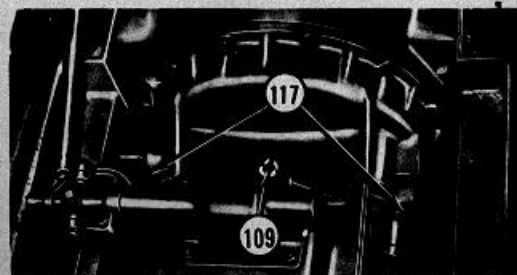

REF. 109. CLUTCH THROWOUT BEARING  
 REF. 117. CLUTCH RELEASE SHAFT

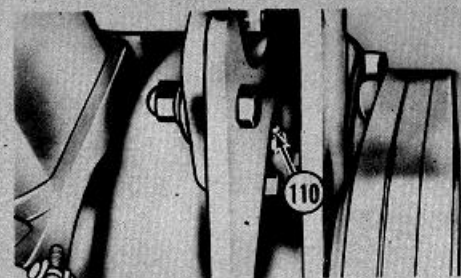

REF. 110. WATER PUMP BEARING

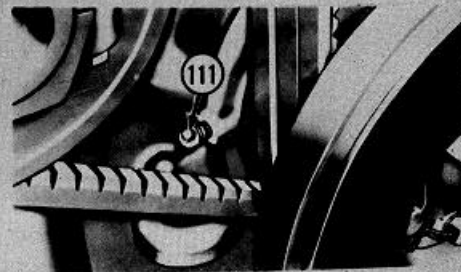

REF. 111. TRUNNION BRACKET

MEC 3810-227-15/17 (14)

Figure 17-Continued.

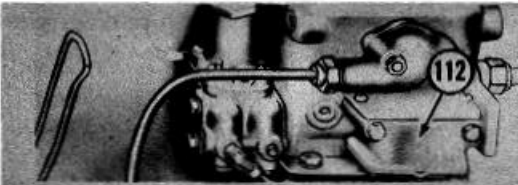

REF. 112. COMPRESSOR INTAKE ELEMENT

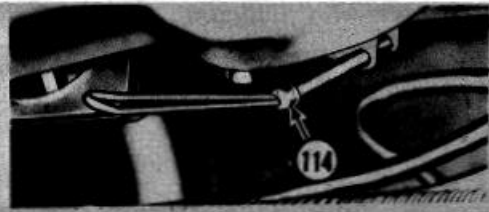

REF. 114. CRANKCASE OIL LEVEL GAGE

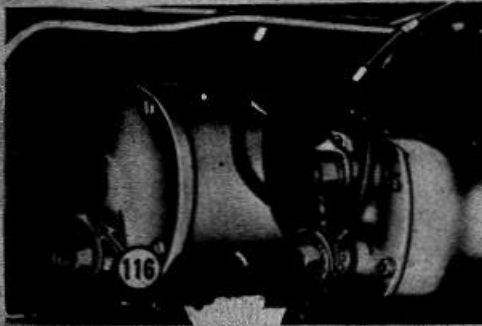

REF. 116. STARTING MOTOR

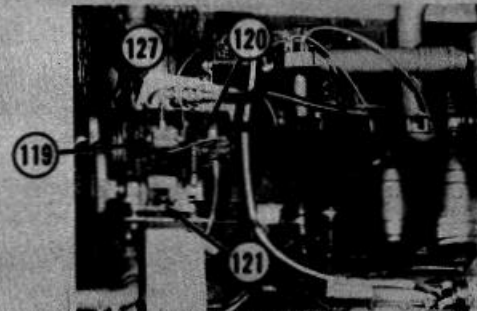

REF. 119. AIR COMPRESSOR FILL AND LEVEL

REF. 120. AIR COMPRESSOR BREATHER

REF. 121. AIR COMPRESSOR DRAIN

REF. 127. WATER PUMP BEARING

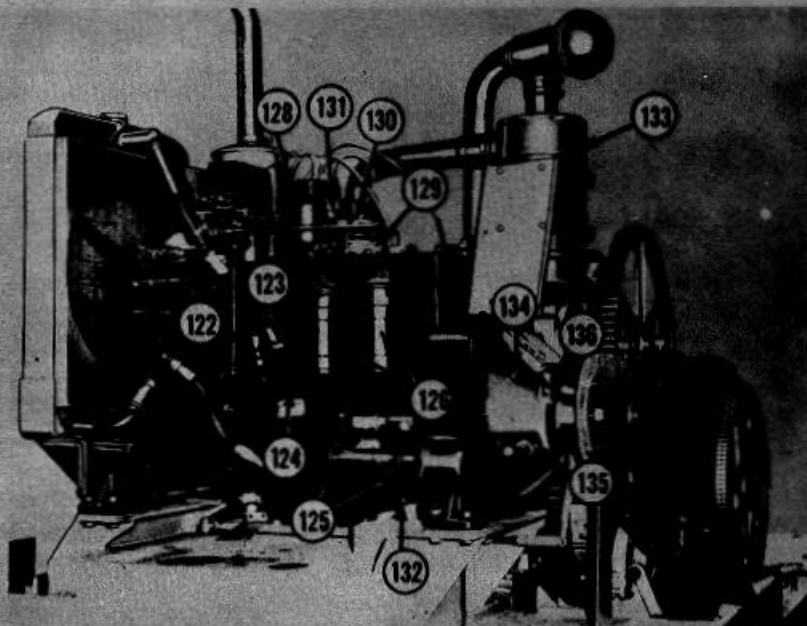

REF. 122. CRANKCASE BREATHER

REF. 123. CRANKCASE OIL FILL CAP

REF. 124. CRANKCASE OIL LEVEL GAGE

REF. 125. STARTING MOTOR

REF. 126. OIL FILTERS

REF. 128. DISTRIBUTOR

REF. 129. THROTTLE PUSH-PULL CABLE

REF. 130. GOVERNOR DRIVE

REF. 131. DISTRIBUTOR RESERVOIR FILL AND LEVEL PLUG

REF. 132. CRANKCASE OIL DRAIN PLUG

REF. 133. AIR CLEANER

REF. 134. CLUTCH THROWOUT BEARING

REF. 135. CLUTCH THROWOUT SHAFT

REF. 136. CLUTCH SHAFT BEARING

MEC 3810-227-15/17 (15)

Figure 17-Continued.

**NOTE: ADD OIL AFTER SERVICE. REFER TO LUBRICATION ORDER.**

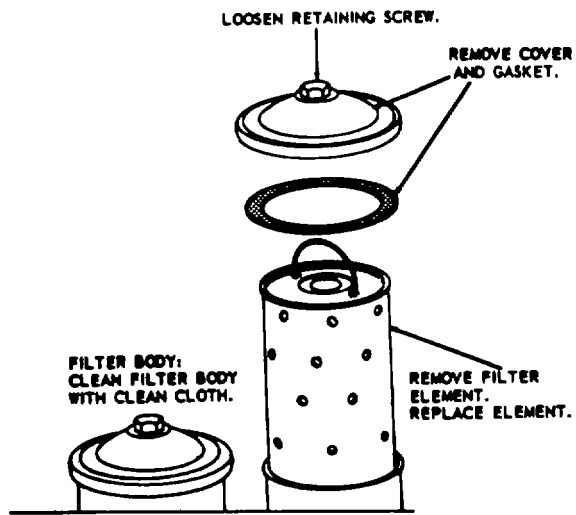

**NOTE: SERVICE THE REMAINING FILTER IN A SIMILAR MANNER.**

MEC 3810-227-15/18

Figure 18. Engine oil filter service.

**UNFASTEN CLIPS AND REMOVE BREATHER**

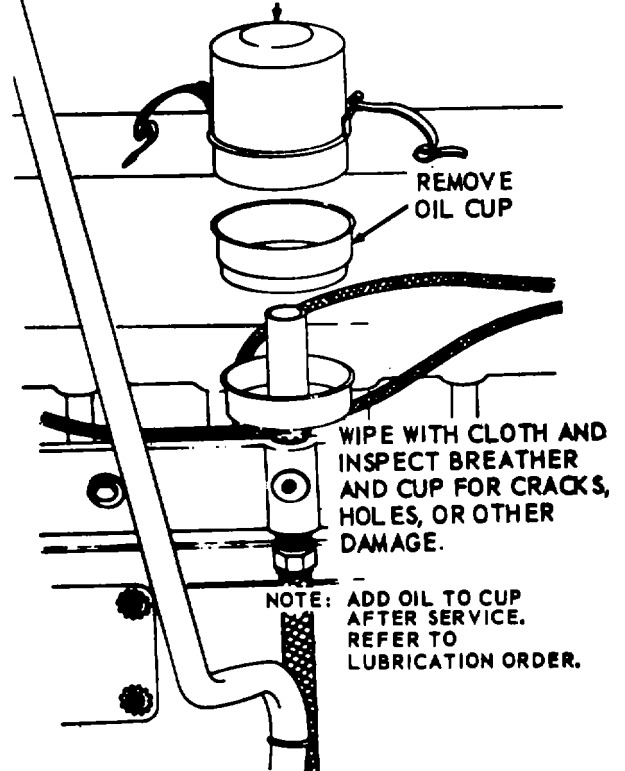

MEC 3810-227-15/19

Figure 19. Engine crankcase breather service.

Figure 17-Continued.



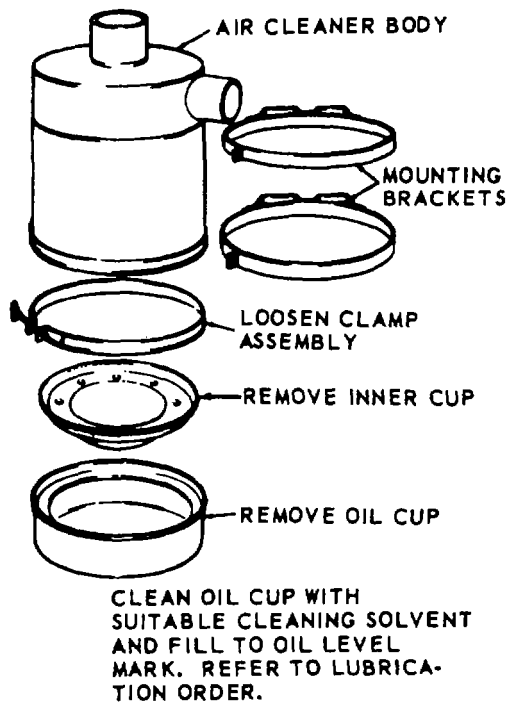

MEC 3810-227-15/20

Figure 20. Engine air cleaner service.

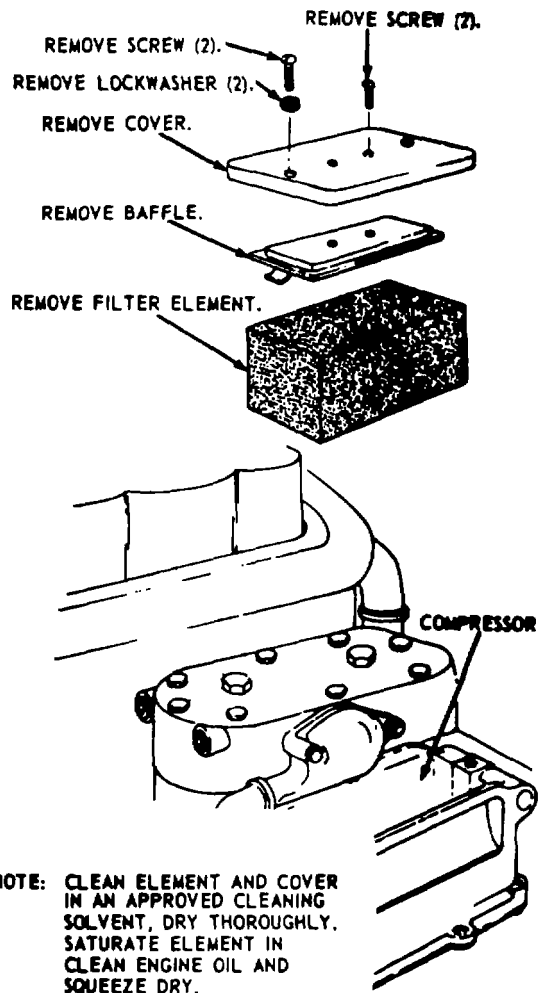

MEC 3810-227-15/21

Figure 21. Carrier engine air compressor breather service.

## Section II. PREVENTIVE MAINTENANCE SERVICES

### 37. General

To insure that the Model 2360 Cran-shovel is ready for operation at all times, it must be inspected systematically, so that defects may be discovered and corrected before they result in serious damage or failure. The necessary Preventative Maintenance Services to be performed are listed and described in paragraphs 38 and 39. The item numbers indicate the sequence of minimum inspection requirements. Defects discovered during operation of the unit shall be noted for future correction, to be made as soon as operation has

ceased. Stop operation immediately if a deficiency is noticed during operation which would damage the equipment if operation were continued. All deficiencies and shortcomings will be recorded together with the corrective action taken on DA Form 2404 at the earliest possible opportunity.

### 38. Daily Preventative Maintenance Services

This paragraph contains as illustrated tabulated listing of preventative maintenance services which must be performed by the opera-

PREVENTIVE MAINTENANCE SERVICES

DAILY

TRUCK MOUNTED

AMERICAN HOIST & DERRICK CO.  
MODELS 2360 AND W2360

CRANE-SHOVEL

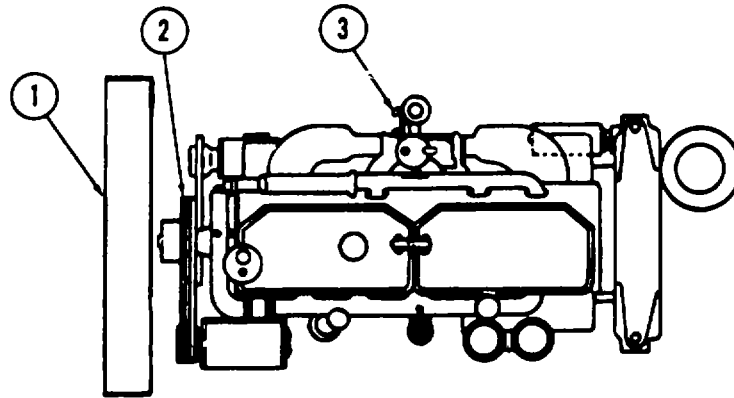

ENGINE, CARRIER, CONTINENTAL

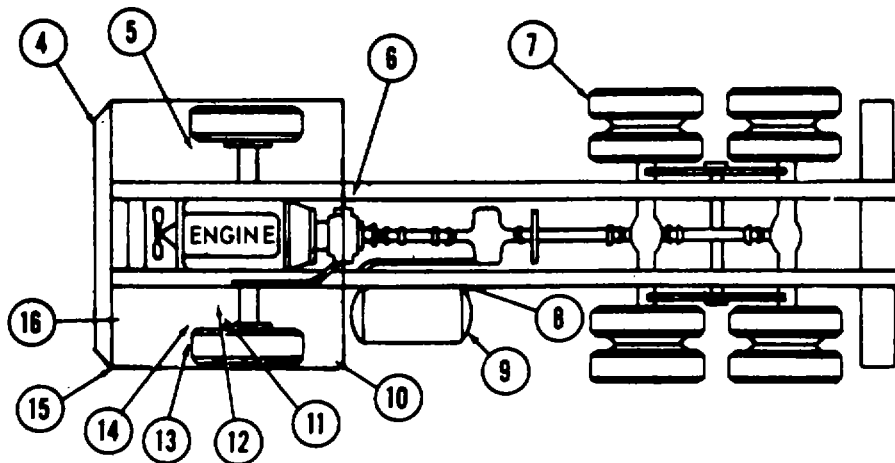

CARRIER

MEC 3810-227-15/22 ①

Figure 22. Daily preventive maintenance services.

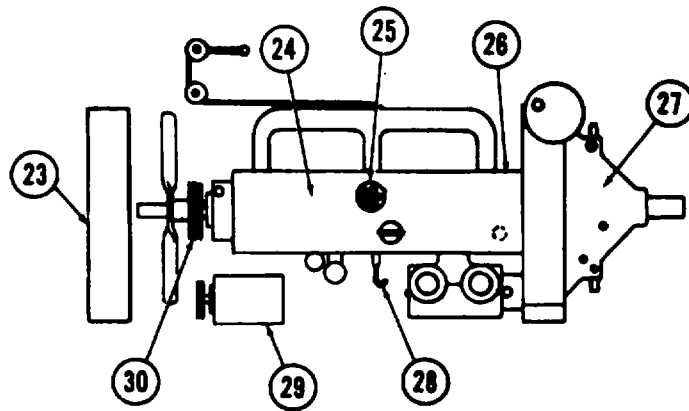

ENGINE, CRANE, CONTINENTAL

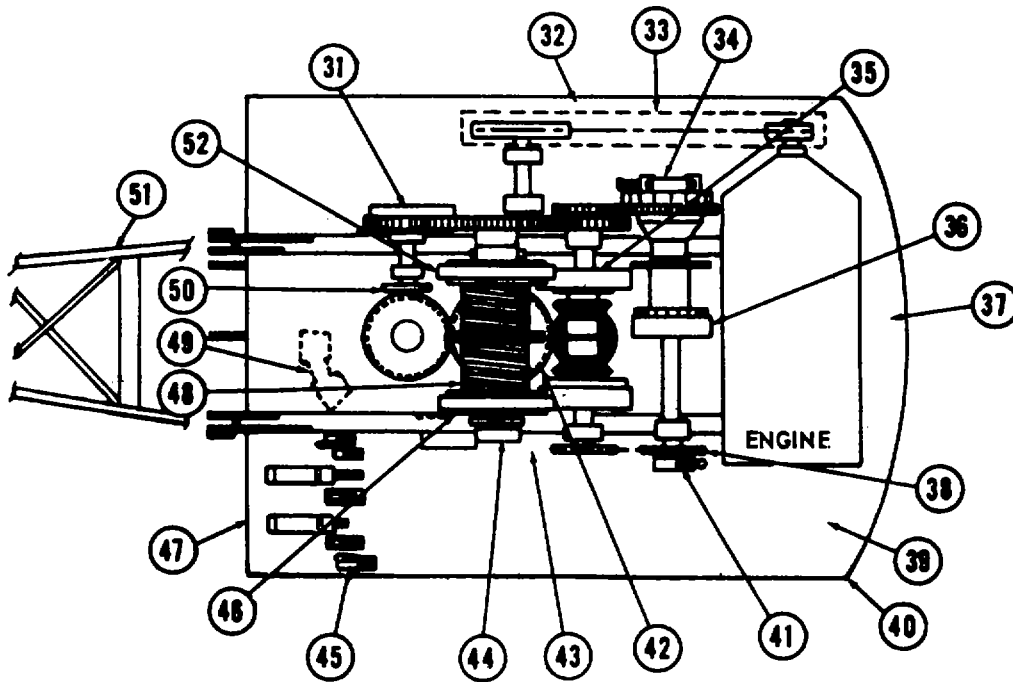

MACHINE DECK

MEC 3810-227-15/22 (2)

Figure 22-Continued.

tor. The item numbers are listed consecutively and indicate the sequence of minimum requirements. Refer

to figure 22 for the Daily Preventative Maintenance Services.

Item	Lubricate in Accordance with Current Lubrication Order	Paragraph reference
1	<i>Radiator.</i> Proper coolant level is ¾ inch above baffle.	
2	<i>Belts.</i> Proper adjustment in a deflection of ¾ inch midway between pulleys. (Weekly)	104, 145
3	<i>Oil Level Gage.</i> Add oil as indicated by level gage. Reference current lubrication order.	
4	<i>Lights.</i> Inspect all lights for loose cables, mountings, cracked lens, and proper operation. Replace defective lamps or bulbs.	110-128
5	<i>Batteries.</i> Tighten loose cables and mountings. Remove corrosion. Inspect for cracks and leaks. Fill to 3/8 inch above the plates. Clean vent hole in filler cap before installing. In freezing weather run engine a minimum of 1 hour after adding water. (Weekly)	9
6	<i>Winterization Equipment.</i> Inspect for damage, loose mounting and proper operation.	262-272
7	<i>Tires.</i> Inspect all tires and check tire inflation. Normal tire pressure is 75 psi.	
8	<i>Fuel Filter.</i> Tighten if leaking. (Clean weekly)	88
9	<i>Fuel Tank.</i> Add fuel as required. Clean filler strainer if necessary.	
10	<i>Fire Extinguisher.</i> Inspect for broken seal.	
11	<p><i>Controls and Instruments.</i> Inspect for damage and loose mounting. With unit operating check for proper operation. Normal operating readings for instruments are as follows;</p> <p>Battery-generator indicator ..... in green area</p> <p>Oil pressure gage ..... 50- 60 psi</p> <p>Oil pressure warning light ..... out with engine running</p> <p>Coolant temperature gage ..... 160-180°F.</p> <p>High temperature warning light ..... out with engine running</p> <p>Air pressure gage ..... 80-105 psi</p> <p>Air pressure warning buzzer ..... Ceases buzzing when proper air pressure has been established</p> <p>Low-air pressure wig-wag- ..... Raises to "up" position when proper air pressure has been established</p>	14
12	<i>Transmission Forward and Reverse Speed Ranges.</i> Check all speed ranges noticing if shifts are smooth and without excessive vibration or unusual noise.	
13	<i>Clutch.</i> Check for proper operation.	
14	<i>Brakes.</i> Check for proper operation.	
15	<i>Steering.</i> Check for proper operation, loose mountings or leaks.	
16	<i>Windshield Wiper.</i> Inspect windshield wiper, blade and arm for damage, loose mounting and proper operation. Replace a defective blade or arm.	257
17	<i>Radiator.</i> Proper coolant level is ¾ inch above baffle.	
18	<i>Fuel Filter.</i> Tighten if leaking. (Clean weekly)	95
19	<i>Engine Clutch.</i> Check for proper operation.	
20	<i>Oil Level Gage.</i> Add oil as indicated by level gage. Reference current lubrication order.	
21	<i>Belts.</i> Proper adjustment is a deflection of ¾ inch midway between pulleys. (Weekly)	131,157
22	<i>Auxiliary Shaft Clutch.</i> Check for proper operation. Adjust if necessary. (Weekly)	190
23	<i>Winterization Equipment.</i> Inspect for damage, loose mounting and proper operation.	273-286
24	<i>Boom Hoist Shaft Clutch.</i> Check for proper operation. Adjust if necessary. (Weekly)	186

**Note 1.**

**Operation.** During operation observe for any unusual noise or vibration.

Item	Lubricate in Accordance with Current Lubrication Order	Paragraph reference
25	<i>Horizontal Reversing Shaft Clutches.</i> Check for proper operation. Adjust if necessary. (Weekly)	187, 188
26	<i>Boom Hoist Brake.</i> Check for proper operation. Adjust if necessary. (Weekly)	191
27	<i>Fuel Tank.</i> Add fuel as required. Clean filter strainer if necessary.	
28	<i>Batteries.</i> Tighten loose cables and mountings. Remove corrosion. Inspect for cracks and leaks. Fill to 3/8 inch above the plates. Clean vent hole in filler cap before installing. In freezing weather run engine a minimum of 1 hour after adding water. (Weekly)	9
29	<i>Lights.</i> Inspect all lights for loose cables, mountings, and proper operation. Replace defective lamps or bulbs.	141-143
30	<i>Swing Brake.</i> Check for proper operation (weekly). This brake has no adjustment. Band must be replaced when defective.	193
31	<i>Fire Extinguisher.</i> Inspect for broken seal.	
32	<i>Controls and Instruments.</i> Inspect for damage and loose mounting. With unit operating check for proper operation. Normal operating readings for instruments are as follows: Battery-generator indicator..... in green area Oil pressure gage ..... 40-50 psi Oil pressure warning light..... out with engine running Coolant temperature gage ..... 160-180°F. High temperature warning light..... out with engine running	15
33	<i>Control Levers and Pedals.</i> Check for proper operation. Check master hydraulic cylinders and lines for leakage and mounting. (Weekly)	
34	<i>Hoist Drum Shaft Clutches.</i> Check for proper operation. Adjust if necessary (Weekly)	189
35	<i>Hoisting Cables.</i> <i>Inspect cables for general condition.</i> Replace frayed or damaged cable.	11,12
36	<i>Hoist Drum Shaft Brakes.</i> Check for proper operation. Adjust if necessary. (Weekly)	192

**Note 1.**

**Operation. During operation observe for any unusual noise or vibration.**

**39. Quarterly Preventative Maintenance Services**

a. This paragraph contains as illustrated tabulated listing of preventative maintenance services which must be performed by Organizational Maintenance personnel at quarterly intervals. A quarterly interval is equal to 3

calendar months, or 250 hours of operation, whichever occurs first.

b. The item numbers are listed consecutively and indicate the sequence of minimum requirements. Refer to figure 23 for the quarterly preventative maintenance services.

Item	Lubricate in Accordance with Current Lubrication Order	Paragraph reference
	<b>Carrier</b>	
1	<i>Radiator.</i> Proper coolant level is 3/4 inch above baffle. Replace cracked or frayed hose. Replace defective radiator. Remove obstructions in the air passages. Tighten all mounting and leaking connections. Correct cap pressure rating is 6 1/2 to 8 lbs.	148, 407
2	<i>Belts.</i> Proper adjustment is a deflection of 3/4 inch midway between pulleys. Replace a worn, frayed or cracked belt.	104, 145
3	<i>Oil Level Gage.</i> Add oil as indicated by level gage. Reference current lubrication order.	

PREVENTIVE MAINTENANCE SERVICES

DAILY

TRUCK MOUNTED

AMERICAN HOIST & DERRICK CO.  
MODELS 2360 AND W2360

CRANE-SHOVEL

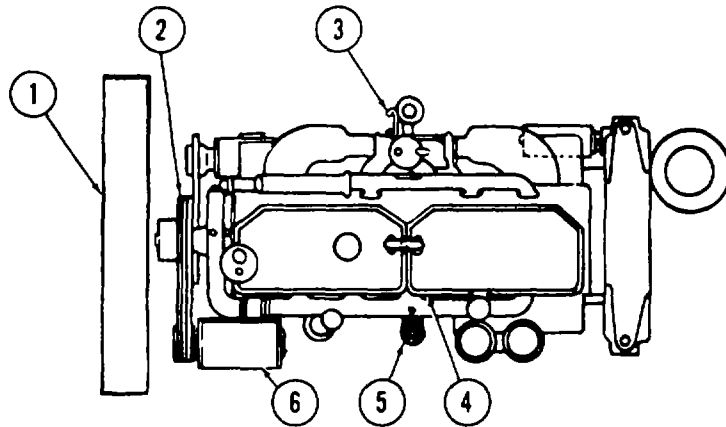

ENGINE, CARRIER, CONTINENTAL

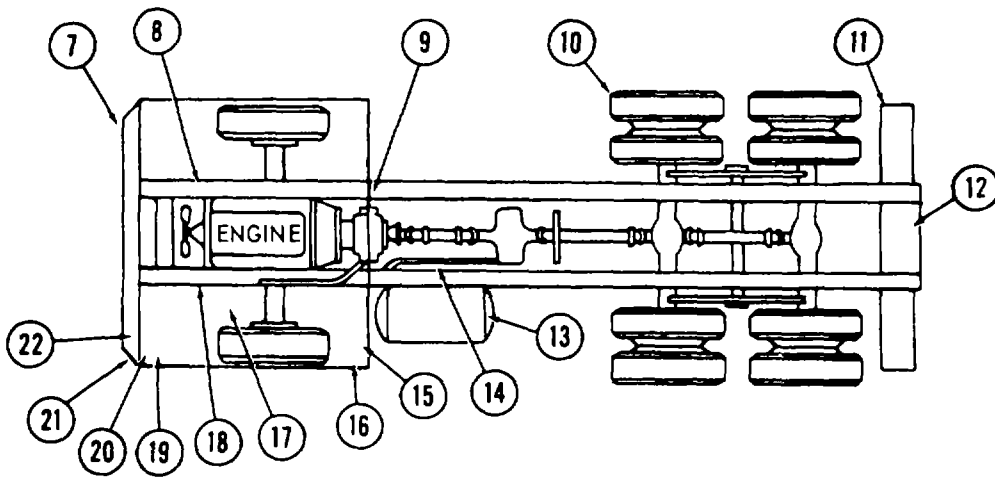

CARRIER

MEC 3810-227-15/23①

Figure 23. Quarterly preventive maintenance services.

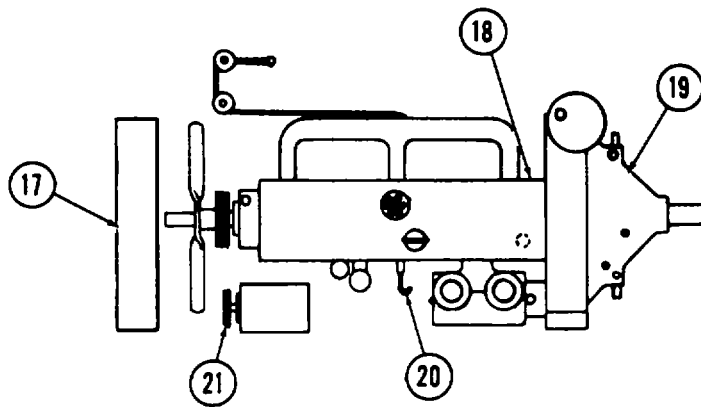

ENGINE, CRANE, CONTINENTAL

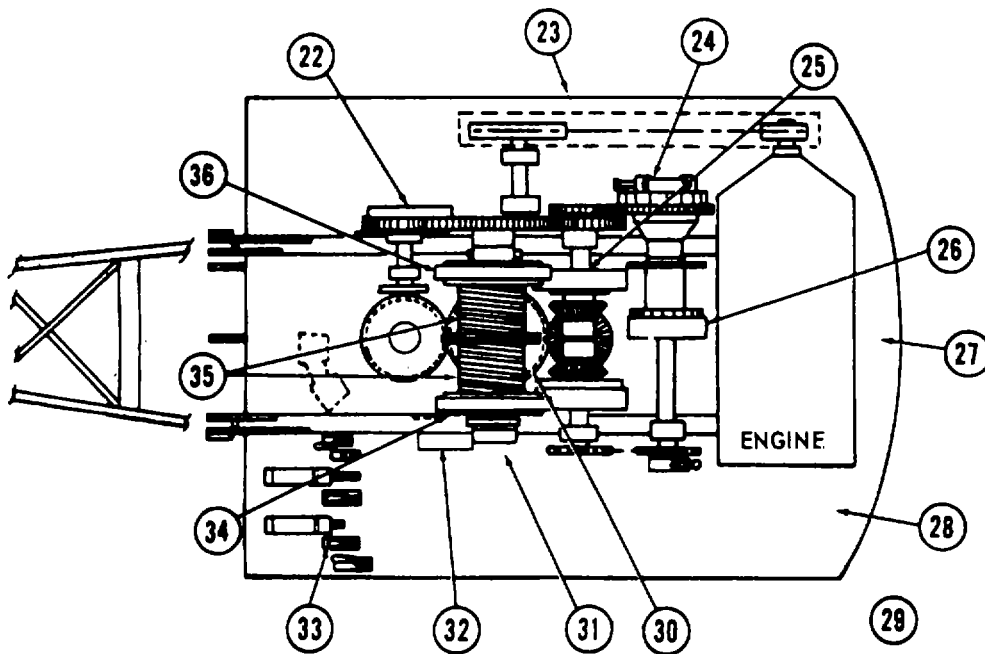

MACHINE DECK

MEC 3810-227-15/23 (2)

Figure 23-Continued.

Item	Lubricate in Accordance with Current Lubrication Order	Paragraph reference
4	<i>Spark Plugs.</i> Replace spark plugs that have cracked insulators and burned electrodes. Clean and set spark plug gaps for 0.025 inch (standard plug) and 0.036 inch (resistor plug). Torque spark plugs to 36 foot pounds. Replace leads which are frayed or broken. Clean and tighten lead connections.	100
5	<i>Ignitor Distributor.</i> Replace pitted or burned points. Proper point gap adjustment is 0.020 inch. (Check adjustment every 500 hours).	99
6	<i>Generator and Regulator.</i> Check generator output, brushes, and regulator points. Replace worn brushes. Adjust or replace a defective regulator.	105, 106
7	<i>Lights.</i> Inspect all lights for loose cables, mountings, cracked lens, and proper operation. See that headlights are correctly aimed. Replace defective lamps or bulbs.	110-123
8	<i>Batteries.</i> Tighten loose cables and mountings. Remove corrosion. Fill to 3/8 inch above the plates. Clean vent hole in filler cap before installing. In freezing weather run engine a minimum of 1 hour after adding water. Repair or replace a cracked or leaking battery.	9, 103
9	<i>Winterization Equipment.</i> Inspect for damage, loose mountings, leaks, and proper operation.	262-272
10	<i>Tires.</i> Inspect all tires and check tire inflation. Normal tire pressure is 75 psi. Replace defective tires.	228
11	<i>Outriggers.</i> Inspect outriggers and pedestals for cracks, breaks and proper operation. Repair or replace a damaged and defective pedestal.	249
12	<i>Pintle Assembly.</i> Inspect pintle assembly for cracks, breaks and proper operation. Repair or replace defective pintle.	248
13	<i>Fuel Tank.</i> Add fuel as required. Tighten loose mounting or leaking lines. Replace leaking fuel tank or defective line. Replace defective cap gasket. Clean filler strainer and cap vent.	86
14	<i>Fuel Filter.</i> Tighten if leaking. Clean or replace a dirty filter element.	88
15	Operator's Cab. Inspect all window-glass and door. Replace cracked or defective glass or door.	251, 252, 256
16	<i>Fire Extinguisher.</i> Inspect for broken seal. Inspect for full charge.	
17	<i>Controls and Instruments.</i> Replace damaged instruments. Tighten loose mounting. With unit operating check for proper operation. Normal operating readings for instruments are as follows: Battery-generator indicator ..... in green area Oil pressure gage ..... 50-60 psi Oil pressure warning light ..... out with engine running Coolant temperature gage ..... 160°-180°F. High temperature warning light ..... out with engine running Air pressure gage ..... 80-105 psi Air pressure warning buzzer ..... Ceases buzzing when proper air pressure has been established Low air pressure wig-wag ..... Raises to "up" position when proper air pressure has been established.	14, 107
18	<i>Transmission Forward and Reverse Speed Ranges.</i> Check all speed ranges noticing if shifts are smooth and without excessive vibration or unusual noise.	
19	<i>Clutch.</i> Check for proper operation. Adjust if necessary.	178
20	<i>Brakes.</i> Check for proper operation. Adjust if necessary. Check air system and components for cracks, damage or loose mounting. Tighten or replace defective parts.	231-242
21	<i>Steering.</i> Check for proper operation, loose mounting or leaks. Tighten leaks and mounting. Replace defective hydraulic lines.	213-217
22	<i>Windshield Wiper.</i> Inspect windshield wiper, blade and arm for damage, loose mounting and proper operation. Replace defective wiper, blade or arm.	257
<b>Note 1.</b> <b>Operation. During operation observe for any unusual noise or vibration.</b> Crane		
23	<i>Radiator.</i> Proper coolant level is ¾ inch above baffle. Replace cracked or frayed hose. Replace defective radiator. Remove obstructions on the air passages.	153, 328



Item	Lubricate in Accordance with Current Lubrication Order	Paragraph reference
	Tighten all mounting and leaking connections. Correct cap pressure rating is 6½ to 8 lbs.	
24	<i>Spark Plugs.</i> Replace spark plugs that have cracked insulators and burned electrodes. Clean and set spark plug gaps for 0.025 inch (standard plug) and 0.035 inch (resistor plug). Torque spark plugs to 35 foot pounds. Replace leads which are frayed or broken. Clean and tighten lead connections.	127
25	<i>Ignitor Distributor.</i> Replace pitted or burned points. Proper point gap adjustment is 0.020 inch. (Check adjustment every 500 hours).	126
26	<i>Fuel Filter.</i> Tighten if leaking. Clean or replace dirty or defective element.	95
27	<i>Clutch.</i> Check for proper operation. Adjust if necessary.	186
28	<i>Oil Level Gage.</i> Add oil as indicated by level gage. Reference current lubrication order.	
29	<i>Generator and Regulator.</i> Check generator output, brushes, and regulator points. Replace worn brushes. Adjust or replace defective regulator.	132-134
30	<i>Belts.</i> Proper adjustment is a deflection of 3/4 inch midway between pulleys. Replace a worn, frayed or cracked belt.	131, 157
31	<i>Auxiliary Shaft Clutch.</i> Inspect for proper operation. Adjust, repair or replace a defective clutch.	190, 614
32	<i>Winterization Equipment.</i> Inspect for damage, loose mountings, leaks and proper operation.	273-286
33	<i>Drive Chain.</i> Inspect drive chain for wear and proper tension. Adjust chain tension. Replace a defective drive chain.	196
34	<i>Boom Hoist Shaft Clutch.</i> Inspect for proper operation. Adjust, repair, or replace a defective clutch.	186, 598
35	<i>Horizontal Reversing Shaft Clutches.</i> Inspect for proper operation. Adjust, repair, or replace a defective clutch.	187, 188, 602
36	<i>Boom Hoist Brake.</i> Inspect for proper operation. Adjust, repair or replace a defective brake.	191
37	<i>Fuel Tank.</i> Add fuel as required. Tighten loose mounting, or leaking lines. Replace leaking fuel tank or defective line. Replace defective cap gasket. Clean filler strainer and cap vent.	92, 308
38	<i>Drive Chain.</i> Inspect chain for wear. Replace a defective chain.	598
39	<i>Batteries.</i> Tighten loose cables and mountings. Remove corrosion. Fill to 3/8 inch above the plates. Clean vent hole in filler cap before installing. In freezing weather run engine a minimum of 1 hour after adding water. Repair or replace a cracked or leaking battery.	9, 130
40	<i>Lights.</i> Inspect all lights for loose cables, mountings, cracked lens, and proper operation. Repair or replace defective lamps or bulbs.	141-143
41	<i>Jaw Clutch.</i> Inspect jaw clutch for wear and proper operation. Replace a defective clutch.	202, 598
42	<i>Swing Brake.</i> Inspect for proper operation. (This brake has no adjustment. Band must be replaced when defective).	193
43	<i>Fire Extinguisher.</i> Inspect for broken seal. Inspect for full charge.	
44	<i>Controls and Instruments.</i> Replace damaged instruments. Tighten loose mountings. With unit operating, check for proper operation. Normal operating readings for instruments are as follows: Battery-generator indicator..... in green area Oil pressure gage..... 40, 60, 50 psi Oil pressure warning light..... out with engine running Coolant temperature gage ..... 160° to 180°F. High temperature warning light..... out with engine running	15, 135
45	<i>Control Levers and Pedals.</i> Inspect for proper operation. Inspect master cylinders and lines for leakage, mounting and wear. Repair or replace damaged or defective parts.	183, 201, 202
46	<i>Hoist Drum Shaft Clutches.</i> Inspect for proper operation. Adjust, repair or replace a defective clutch.	189, 590
47	<i>Operator's Cab.</i> Inspect all window glass and doors. Replace cracked or defective doors.	209, 210

Item	Lubricate in Accordance with Current Lubrication Order	Paragraph reference
48	<i>Hoisting Cables.</i> Inspect cables for general condition. Replace worn, frayed or damaged cables.	11,12
49	<i>Load Rollers.</i> Inspect load rollers for wear and proper operation. Adjust if necessary. Correct clearance between load roller and roller path in 0.047 inch.	199, 200
50	<i>Drive Chain.</i> Inspect chain for wear. Replace a defective chain.	614
51	<i>Boom Assembly.</i> Inspect boom assembly and cable sheaves for cracks, breaks, and general condition. Repair or replace defective parts.	204
52	<i>Hoist Drum Shaft Brakes.</i> Inspect for proper operation. Adjust, repair or replace defective brakes.	192

**Note 1. Operation. During operation observe for any unusual notes or vibration.**  
**2. Adjustments. Make all necessary adjustments during operational test.**

### Section III. TROUBLESHOOTING

#### 40. General

This section provides information useful in diagnosing and correcting unsatisfactory operation or failure of the crane-shovel and its components. Each

trouble symptom stated is followed by a list of probable causes of the trouble. The possible remedy recommended is described opposite the probable cause.

#### 41. Engine Lacks Power

<i>Probable cause</i>	<i>Possible remedy</i>
Air cleaner choked .....	Replace or repair air cleaner (paras. 84 and 91).
Fuel pump clogged.....	Replace or repair fuel pump (paras. 88 and 95).
Air in fuel system .....	Tighten all fuel line connections. Replace defective lines (paras. 85 and 92).
Faulty fuel.....	Drain and replace fuel.
Defective carburetor.....	Repair carburetor (paras. 86 and 93).
Burnt or faulty valves .....	Replace or repair valves (paras. 171 and 174).
Defective piston rings.....	Replace piston rings (parts. 354 and 434).
Blown head gasket.....	Replace head gasket (paras. 340 and 428).

#### 42. Starters Fail to Operate

<i>Probable cause</i>	<i>Possible remedy</i>
Poor electrical connection .....	Clean and tighten battery cables and other electrical connections. Replace if necessary (para. 9b).
Starter button defective.....	Replace button (paras. 107 and 135).
Faulty batteries .....	Replace batteries (para. 9b).
Faulty starter .....	Replace starter (paras. 102 and 129).
Starter brushes worn .....	Replace brushes (paras. 102 and 129).
Defective starter .....	Repair starter (paras. 102 and 129).
Internal engine seizure.....	Replace the engine (paras. 297 and 298).

#### 43. Engines Fail to Start or Are Hard to Start

<i>Probable cause</i>	<i>Possible remedy</i>
Lack of fuel.....	Fill fuel tank
Clogged carburetor screen .....	Service carburetor screen (paras. 86 and 95).
Air cleaner clogged .....	Service air cleaner (para. 36).
Improper valve learn .....	Adjust valves (paras. 171 and 174).
Batteries too low to turn over engine .....	Charge or replace batteries (para. 9b).
Defective starter.....	Replace starter (paras. 102 and 129).
Defective spark plugs .....	Replace spark plugs (paras. 100 and 127).
Carburetor out of adjustment.....	Adjust carburetor (paras. 86 and 93).
Defective distributor points .....	Replace distributor points (paras. 99 and 125).
Defective carburetor.....	Repair carburetor (paras. 300 and 383).

#### 44. Engines Miss or Vibrate Excessively

<i>Probable cause</i>	<i>Possible remedy</i>
Faulty carburetor .....	Replace defective carburetor (paras. 86 and 93).
Governor out of adjustment .....	Adjust the governor (paras, 87 and 94).
Leaking fuel line.....	Replace defective fuel line (paras. 85 and 92).
Faulty distributor points .....	Replace distributor points (paras. 99 and 125).
Distributor not timed properly .....	Time distributor (para. 99).
Defective spark plugs .....	Replace spark plugs (paras. 100 and 127).
Broken fan .....	Replace fan (paras. 146 and 157).

#### 45. Engines Stall Frequently

<i>Probable cause</i>	<i>Possible remedy</i>
Idling speed too low.....	Adjust idling speed to a minimum of 600 rpm (paras. 87 and 94).
Operating water temperature too low .....	Replace thermostat (paras. 150 and 155).
Governor hunting .....	Correct governor adjustment (paras. 87 and 94).
Defective carburetor .....	Repair carburetor (paras. 300 and 383).
Defective distributor .....	Repair distributor (paras. 324-326 and 399-401).
Defective valves .....	Replace or repair valves (paras. 171 and 174).

#### 46. Engines Overheat

<i>Probable cause</i>	<i>Possible remedy</i>
Loose fan belt .....	Adjust fan belt (paras. 145 and 157).
Defective thermostat .....	Replace thermostat (paras. 150 and 155).
Collapsed hose or loose hose connections.....	Check condition of hose. Tighten hose connections. Replace defective hose (paras. 148 and 153).
Coolant low in radiator.....	Fill radiator with proper coolant.
Insufficient oil in crankcase .....	Check oil level; fill as necessary (LO 5-3810-227-15).
Water pump and generator drive belt loose or slip.....	Adjust belt. Replace worn or damaged belt (paras. 104 and 131).
Faulty water pump.....	Replace water pump (paras. 149 and 158).
Thermostat defective .....	Replace defective thermostat (paras. 150 and 155).
Hose leaks .....	Tighten clamps. Replace defective hose (paras. 148 and 153).
Loose or open drain plugs .....	Inspect and tighten. Replace defective drain plug.
Fan belt loose .....	Tighten fan belt.
Defective radiator .....	Replace radiator (paras. 328 and 407).
Defective water pump .....	Repair water pump (paras. 332 and 411).

#### 47. Excessive Black Smoke From Exhaust

<i>Probable cause</i>	<i>Possible remedy</i>
Faulty carburetor .....	Replace carburetor (paras. 86 and 93).
Air cleaner clogged .....	Clean, air cleaner. Replace a faulty air cleaner (paras. 84 and 91).
Excessive oil in crankcase .....	Drain oil and fill crankcase (LO 5-3810-227-15).

#### 48. Engine Temperature Fails to Rise

<i>Probable cause</i>	<i>Possible remedy</i>
Thermostat defective .....	Replace defective thermostat (paras. 150 and 155).
Defective temperature gage .....	Replace temperature gage (paras. 107 and 135).

#### 49. Engine Starts but Will Not Run

<i>Probable cause</i>	<i>Possible remedy</i>
Low compression .....	Adjust valve clearance (paras. 171 and 174).
Defective carburetor .....	Replace carburetor (paras. 86 and 93).
Air intake clogged .....	Remove obstructions (paras. 84 and 91).
Defective fuel pump .....	Replace fuel pump (paras. 88 and 95).
Defective distributor points.....	Replace distributor points (paras. 99 and 125).

**50. Engine Oil Pressure Low**

*Probable cause*

*Possible remedy*

Defective oil pump .....Replace or repair oil pump (paras. 351 and 431).

**51. Engine Knocks and Other Noises**

*Probable cause*

*Possible remedy*

Defective crankshaft main bearings .....Replace bearings (paras. 375-377 and 463-465).  
Defective connecting rod bearings.....Replace bearings (paras. 355-357 and 435-437).  
Loose pistons or wrist pins.....Replace pins (paras. 355-357 and 435-437).  
Broken piston rings.....Replace rings (paras. 355-357 and 435-437).  
Broken valve springs.....Replace springs (paras. 343-345 and 428-425).  
Defective camshaft bearings.....Replace bearings (paras. 371-373 and 459-461).  
Worn timing gears.....Replace gears (paras. 367-369 and 455-457).  
Loose engine mounting bolts.....Tighten or replace mounting bolts (para. 363).

**52. Engine Oil Consumption High**

*Probable cause*

*Possible remedy*

Worn, broken, or stuck piston rings.....Replace rings (paras. 355-357 and 435-437).  
Worn pistons.....Replace pistons (paras. 355-357 and 435-437).  
Worn valve guides .....Replace guides (paras. 343-345 and 423-425).

**53. Engine Clutch Noisy**

*Probable cause*

*Possible remedy*

Defective clutch shaft bearing.....Replace bearings (paras. 335-338 and 439-441).  
Broken lever pins or levers.....Replace levers or pins (paras. 336-338 and 439-441).  
Broken collar or yoke .....Replace collar or yoke (paras. 336-338 and 439-441).

**54. Engine Clutch Drags**

*Probable cause*

*Possible remedy*

Warped clutch plates .....Replace clutch plates (paras. 336-338 and 439-441).  
Worn or broken levers or pins .....Replace levers and pin (paras. 336-338 and 439-441).

**55. Engine Clutches Slip or Will Not Engage Properly**

*Probable cause*

*Possible remedy*

Incorrect clutch adjustment .....Adjust clutches paras. 178 and 185).  
Control linkage loose or out of adjustment.....Tighten or adjust linkage (paras. 178 and 185).  
Clutch pedal and cross-shaft defective .....Replace a damaged clutch pedal and cross-shaft (para. 443).

**56. Fuel Consumption Excessive**

*Probable cause*

*Possible remedy*

Fuel tanks and lines leak or are defective.....Replace fuel tank. Replace fuel links (paras. 85 and 92).  
Carburetor faulty or out of adjustment.....Adjust or replace carburetor (paras. 86 and 93).  
Faulty fuel pumps.....Replace fuel pumps (paras. 88 and 95).

**57. Lights Fail**

*Probable cause*

*Possible remedy*

Defective or burned out lamps .....Replace lamps.  
Short In wiring .....Replace wiring (paras. 113 and 143).  
Defective switch.....Replace switch (paras. 107 and 135).  
Loose wiring connections.....Tighten connections.

**58. Lights Dim**

*Probable cause*

*Possible remedy*

Lenses dirty or tarnished.....Clean lenses.  
Loose wiring.....Check wiring.

### 59. Primary Drive Chain Excessively Noisy

<i>Probable cause</i>	<i>Possible remedy</i>
Defective chain .....	Replace chain (para. 594)
Worn sprocket .....	Replace sprocket (para. 594).
Improper adjustment .....	Adjust primary drive chain (para. 196).

### 60. Crane Hoist Gears Noisy

<i>Probable cause</i>	<i>Possible remedy</i>
Worn gear teeth .....	Replace gear (para. 590-592).
Worn or scored bearings .....	Replace bearings (para. 590-592).
Bent hoist shaft .....	Replace hoist shaft (para. 590-592).

### 61. Crane Swing Gear Noisy or Pulsations in Operations

<i>Probable cause</i>	<i>Possible remedy</i>
Worn gear teeth .....	Replace gear (paras. 606 and 610).
Worn or scored bearings .....	Replace bearings (paras. 606 and 610).
Bent swing shaft .....	Replace swing shaft (para. 610).

### 62. Crane Boom or Hoist Operation Rough

<i>Probable cause</i>	<i>Possible remedy</i>
Bent drive shaft .....	Replace drive shaft (paras. 594-596).
Inner boom gear binding .....	Replace gear bushing (paras. 590-592).
Broken shaft bearings .....	Replace shaft bearings (paras. 590-592).
Broken shaft .....	Replace shaft (paras. 590-592).

### 63. Cables Tend to Flatten

<i>Probable cause</i>	<i>Possible remedy</i>
Sheave channel clearance too great .....	Replace sheaves (paras. 204 and 205).
Defective cables .....	Replace cables (para. 11).
Incorrect cable size .....	Install correct cable (paras. 11 and 12).

### 64. Revolving Frame Teeters or Will Not Swing

<i>Probable cause</i>	<i>Possible remedy</i>
Conical rollers out of adjustment .....	Adjust rollers (paras. 199 and 200).
Worn rollers .....	Replace hook rollers (paras. 199 and 200).
Swing clutches out of adjustment .....	Adjust swing clutch (paras. 187-188).
Worn roller shaft .....	Replace roller shaft (paras. 199 and 200).
Worn or loose shaft bushing .....	Replace bushing (paras. 199-200).
Worn or scored bushings .....	Replace bushings (paras. 199-200).
Defective ring or pinion gears .....	Replace gears (paras. 610 and 622).

### 65. Continuous Humming Noise or Noisy Front Axle When Driving

<i>Probable cause</i>	<i>Possible remedy</i>
Wheel bearings too light .....	Inspect and adjust wheel bearings (para. 225).
Lack of lubrication or use of improper grade of lubricant in universal joints, wheel bearings, transmission, transfer case.	Check lubricant for correct amount and proper grade as specified in LO 5-3810-227-15.
Broken axle .....	Replace axle (paras. 547-549).
Worn or broken differential or pinion gears .....	Replace gears (paras. 551-553).
Worn or broken differential or pinion bearings .....	Replace bearings (paras. 551-553).
Worn splines on axle shaft .....	Replace axle shaft (paras. 547-549).
Worn splines on pinion shaft .....	Replace pinion shaft (paras. 551-553).

### 66. Steering Assembly Cracks When Turning

<i>Probable cause</i>	<i>Possible remedy</i>
Knuckle bearing rollers and cups scored or worn .....	Inspect and lubricate (LO 6-3810227-15), as necessary.
Wheel bearing rollers and cups scored or worn .....	Inspect wheel bearings and replace as necessary (para. 225).
Defective shock absorbers .....	Replace shock absorbers (para. 229).

## 67. Steering Head

<i>Probable cause</i>	<i>Possible remedy</i>
Tires not inflated to proper pressure .....	Check and inflate all tires to proper pressure (75 psi).
Excessive friction in tie rod or drag link joints .....	Inspect and adjust (paras. 218 and 222) and lubricate as required (LO 5-3810-227-15).
Excessive friction in steering gear assembly .....	Adjusting steering gear (para. 218).
Loose pump belt or pulley .....	Adjust pump belt and replace a faulty belt or pulley if necessary (paras. 145 and 149).
Ruptured or weak spot in tire .....	Inspect tube for rupture and replace tire and tube if necessary (para. 228).
Lack of fluid .....	Tighten all lines and fittings and replace a defective line or fitting. Fill to level with proper Hydraulic oil as specified in LO 5-3810-227-16.
Faulty operation of steering valves .....	Clean and adjust steering valves. Replace as necessary (paras. 216 and 217).
Steering wheel creeps .....	Adjust control valve or replace if necessary (paras. 217-218).
Shock absorber defective .....	Replace a defective shock absorber (para. 229).

## 68. Improper Air Pressure

<i>Probable cause</i>	<i>Possible remedy</i>
Air pressure in system is above normal .....	Check governor settings. Adjust air compressor unloading valves (paras. 479-481). Replace governor if necessary. (para. 479).
Air reservoir damaged.....	Inspect air reservoir and replace if necessary (para. 239).

## 69. Carrier Handbrake Does Not Hold When Applied

<i>Probable cause</i>	<i>Possible remedy</i>
Handbrake linkage out of adjustment .....	Adjust linkage (para. 14c).

## 70. Carrier Has No Brake Action, Insufficient Action or Brakes Apply Slowly

<i>Probable cause</i>	<i>Possible remedy</i>
Improper brakeshoe adjustment .....	Adjust brakeshoes (paras. 241 and 242).
Worn brake linings .....	Adjust for lining wear or replace brakeshoes or linings (paras. 241 and 242).
Blocked, bent, or broken tubing or hose .....	Remove obstruction in line or replace faulty tubing (para. 232).
Brake valve delivery pressure below normal .....	If brake valve is defective, replace unit (para. 238).
No air pressure .....	Replace or repair air compressor (paras. 479-481)

## 71. Brakes Release too Slowly With Pedal Released

<i>Probable cause</i>	<i>Possible remedy</i>
Insufficient brakeshoe clearance.....	Adjust brakeshoes if clearance is insufficient (paras. 241 and 242).
Weak or broken valve diaphragm return spring.....	Replace brake valve (para. 234).
Defective quick release valve .....	Replace quick release valve (para. 235).

## 72. One Brake Drags With Pedal Released

<i>Probable cause</i>	<i>Possible remedy</i>
Insufficient brakeshoe clearance.....	Adjust brakeshoe clearance (paras. 241 and 242).
Blocked or defective quick release valve .....	Clean or replace faulty unit (para. 235).
Weak or broken brakeshoe return spring.....	Replace faulty spring (paras. 241 and 242).
Brakeshoe binds on anchor pin .....	Remove shoe; clean and lubricate anchor pins (paras. 241 and 242).

## 73. Brakes Grab When Pedal is Depressed

<i>Probable cause</i>	<i>Possible remedy</i>
Brakeshoe clearance too great .....	Adjust clearance (paras. 241 and 242).

Grease or oil on linings.....	Clean linings or replace brakeshoes or linings (paras. 241 and 242).
Drums-out-of-round.....	Replace drum (paras. 225 and 227).
Defective brake valve .....	Replace faulty unit (para. 235).
Brakes need relining.....	Replace brakeshoes (paras. 225 and 227).
Brake chamber diaphragm leaks.....	Tighten all fittings. If caused by broken or faulty unit, replace brake chamber (par. 234).

#### 74. Carrier Transmission Excessively Noisy in Operation

<i>Probable cause</i>	<i>Possible remedy</i>
Insufficient or improper lubricant .....	Fill to level with proper lubricant as specified in LO 5-3810-227-16.
Rods and lever out of adjustment .....	Adjust the alinement (paras. 244-246).
Unit out of line.....	Tighten all mountings securely.
Loose transmission mounting bolts.....	Tighten or replace bolts (paras. 471 and 473).
Defective gears .....	Replace gears (paras. 471 and 473).
Defective bearings .....	Replace bearings (paras. 471 and 473).
Defective spline shaft .....	Replace spline shaft (paras. 471 and 473).

#### 75. Carrier Gear Shifting Difficult

<i>Probable cause</i>	<i>Possible remedy</i>
Broken or bent yokes.....	Replace yokes or shifting bar housing (paras. 471 and 473).
Defective gear teeth .....	Replace gear (paras. 471 and 473).
Housing and assembly out of alinement.....	Replace housing assembly (paras. 471 and 473).

#### 76. Carrier Transfer Case Noisy

<i>Probable cause</i>	<i>Possible remedy</i>
Loose transfer case mounting bolts .....	Tighten or replace bolts (paras. 475 and 477).
Defective gears .....	Replace gears (paras. 475 and 477).
Defective bearings .....	Replace bearings (paras. 475 and 477).
Defective spline shaft .....	Replace spline shaft (paras. 475 and 477).

#### 77. Carrier Transmission and Transfer Case Overheat

<i>Probable cause</i>	<i>Possible remedy</i>
Insufficient or improper lubricant .....	Fill to level with proper lubricant (LO 5-3810-227-15).
Rods and levers out of adjustment .....	Adjust the alinement (paras. 244, 245, and 246).

#### 78. Carrier Rear Axle and Tandem Unit Noisy

<i>Probable cause</i>	<i>Possible remedy</i>
Wheel bearings worn.....	Replace wheel bearings (para. 227).
Lack of lubricant or use of improper grade of lubricant in differential.	Check lubrication for proper grade and amount as specified in LO 5-3810-227-15.
Differential gears worn or out of adjustment.....	Replace or adjust gears (paras. 567-569).
Broken pinion or differential gears .....	Replace gears (paras. 567-569).
Worn or defective differential or pinion bearings .....	Replace bearings (paras. 567-569).
Worn splines on pinion shaft or propeller shaft yoke.....	Replace shaft or yoke (paras. 567-569).
Worn or defective equalizing beam .....	Replace equalizing beam (paras. 563-565).
Worn or defective torque rods.....	Replace torque rods (paras. 559-561).

### Section IV. RADIO INTERFERENCE SUPPRESSION

#### 79. General Methods Used to Attain Proper Suppression

Essentially, suppression is attained by providing a low resistance path to ground for the stray currents. The

methods used include shielding the ignition and high-frequency wires, grounding the frame with bond straps, and using capacitors and resistors. For gen-

eral information on radio interference suppression see TM 11-483.

## 80. Interference Suppression Components

### a. Primary Suppression Components.

- (1) The interference ground strap is illustrated on figure 24.
- (2) The suppression cover is illustrated on figure 24.

### b. Secondary Suppression Components (Crane).

- (1) *Tooth-type lockwashers.*
  - (a) The crane generator is mounted on the left side of the engine and is grounded by internal-external tooth lockwashers to suppress radio interference.

#### Note.

**If there is excessive sparking of the brushes, it will be necessary to clean the commutator and install new brushes (para. 105).**

- (b) The crane generator regulator is mounted on top of the engine and is grounded with internal external type lockwashers to suppress radio interference.
- (c) The crane distributor is mounted to the engine head and is grounded with internal-external type lockwashers to suppress radio interference.
- (d) The crane starter is mounted on the lower-left side of the engine and is grounded with internal-external type lockwashers to suppress radio interference.
- (e) The starter solenoid is mounted on the starter and is grounded by internal-external tooth-type lockwashers and is suppressed from solenoid to starter motor with a ground lead.
- (f) The crane engine is equipped with special shielded and suppressed spark plugs to suppress radio interference.
- (g) Instructions for replacement of the above suppression components will be found in the applicable maintenance section of this manual.

### (2) *Shielded cables.*

- (a) The crane generator is equipped with a shielded cable connecting the generator regulator.
- (b) The ignition cables that connect the spark plugs to the distributor are of the shielded type.

### c. Secondary Suppression Components (Carrier).

- (1) *Tooth-type lockwashers.*
  - (a) The carrier generator is mounted on the left side of the engine and is grounded by internal-external tooth-type lockwashers to suppress radio interference.
  - (b) The generator regulator is mounted on the top-rear side of the firewall with internal-external tooth-type lockwashers to suppress radio interference.
  - (c) The carrier distributor is mounted in the left side of the engine and is grounded with internal-external tooth-type lockwashers to suppress radio interference.
  - (d) The starter motor and solenoid are mounted on the lower-rear right side of the engine with internal external tooth-type lockwashers and ground strap to suppress radio interference.
  - (e) The carrier engine is equipped with special suppressed spark plugs to suppress radio interference.
  - (f) Instructions for replacement of the above suppression components will be found in the applicable maintenance section of this manual.

### (2) *Shielded cables.*

- (a) The carrier generator is equipped with a shielded cable connecting the generator to the generator regulator.
- (b) The ignition cables that connect the spark plugs to the distributor are of the shielded type.

#### Note.

**Do not pull on the cable or twist the braided shielding. Gently work the cable from side to side and free the rubber seal. Do not use sharp metal tools to install the rubber seal.**



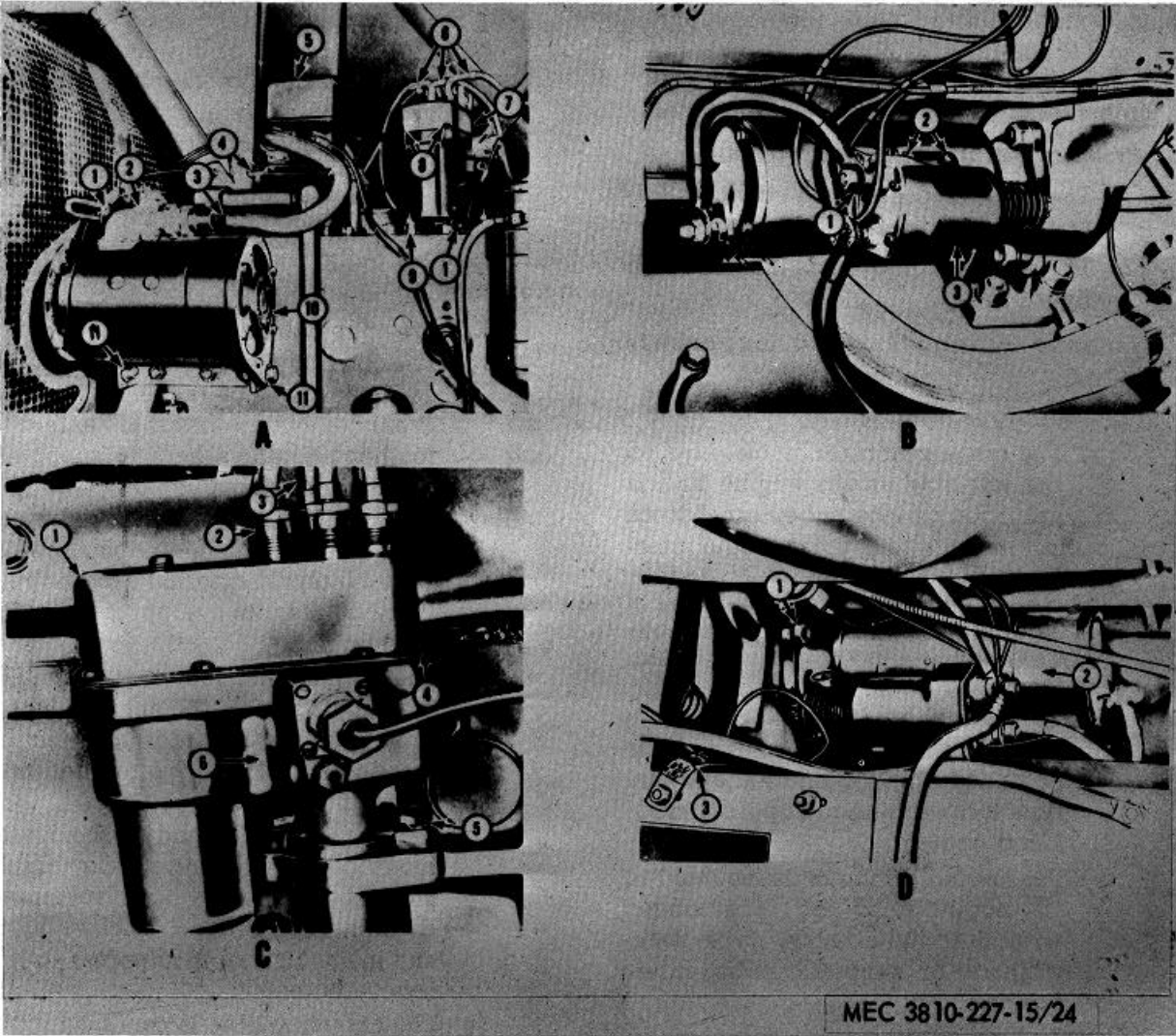

Figure 24. Radio suppression components.

- 1 Tooth-type lockwasher
- 2 Suppression receptacle
- 3 Woven-type shielded cable
- 4 Tooth-type lockwasher
- 5 Generator regulator
- 6 Ignition cables
- 7 Distributor
- 8 Tooth-type lockwasher
- 9 Spark plug
- 10 Generator
- 11 Tooth-type lockwasher

A-Crane generator, generator regulator, and distributor, D-Carrier starter motor. radio suppression.

- 1 Cover, suppression
- 2 Nut, connector
- 3 Ignition cables
- 4 External tooth-type lockwasher
- 5 Internal tooth-type lockwasher
- 6 Distributor

C-Crane and carrier distributor.

- 1 External tooth-type lockwasher
- 2 Starter motor
- 3 Strap, ground suppression

- 1 Tooth-type lockwasher
  - 2 Tooth-type lockwasher
  - 3 Solenoid
- B-Crane and carrier starter motor and solenoid.

### 81. Replacement of Suppression Components

For replacement, suppression components must be identical to the original part. Capacitors must be the same size and have the same microfarad and voltage rating as the part being replaced. Special care must be taken to be certain there is a good metal-to-metal contact with washers and bonding straps.

### 82. Testing or Radio Interference Suppression Components

Test the capacitors for leaks and shorts on a capacitor tester; replace defective capacitors. If test equipment is not available and interference is indicated, isolate the cause of interference by trial-and-error method of replacing each capacitor in turn until the cause of interference is located and eliminated.

## Section V. CARRIER ENGINE FUEL SYSTEM

### 83. General

The fuel system consists of 100-gallon tank; a fuel shutoff valve connected to the tank; a fuel line connected to the electric-type fuel pump; a connecting fuel line leading to the downdraft-type carburetor, mounted on the right side of the engine; and an oil-bath type air cleaner; with a connecting hose from the air cleaner to the rear of the carburetor. A gear-driven governor is connected to the carburetor and regulates the engine speed by increasing or decreasing the amount of fuel mixture entering the cylinder. This governor is powered by a cable leading from the bottom of the governor to the lower end of the distributor shaft.

### 84. Engine Air Cleaner

a. *Removal and Installation.* Remove and install the air cleaner as instructed on figure 25.

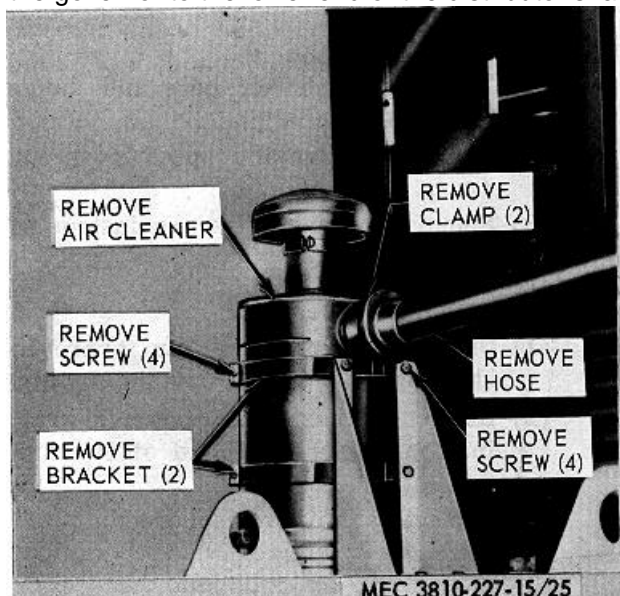
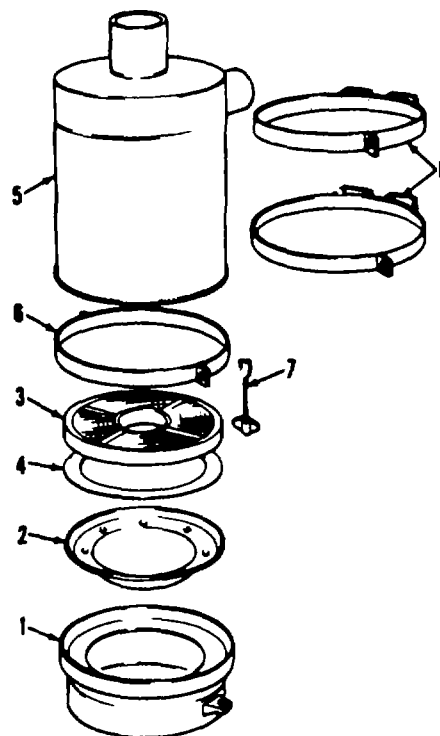

Figure 25. Carrier engine air cleaner, removal and installation.



MEC 3810-227-15/26

- |                  |                    |
|------------------|--------------------|
| 1 Cup assembly   | 5 Body assembly    |
| 2 Inner cup      | 6 Band assembly    |
| 3 Housed element | 7 Bolt assembly    |
| 4 Gasket         | 8 Mounting bracket |

Figure 26. Carrier engine air cleaner, exploded view.

b. *Disassembly.* Disassemble the air cleaner as illustrated on figure 26.

c. *Cleaning, Inspection, and Repair.*

- (1) Clean all parts with an approved cleaning solvent and dry thoroughly.
- (2) Inspect all parts for fractures and other damage.
- (3) Repair or replace parts as necessary.

d. *Reassembly.* Reassemble the air cleaner as illustrated on figure 26.

## 85. Fuel Tank, Lines, and Fittings

a. *Service.* Service the carrier engine fuel tank as instructed in figure 27.

b. *Removal and Installation.* Remove and install the fuel tank, lines, and fittings as instructed in figure 28.

c. *Cleaning, Inspection, and Repair.*

- (1) Clean all parts with an approved cleaning solvent.
- (2) Inspect all parts for defective condition.
- (3) Repair or replace damaged parts as necessary. Replace all gaskets.

## 86. Carburetor

a. *Service.* Service the carrier engine carburetor screen as instructed in figure 29.

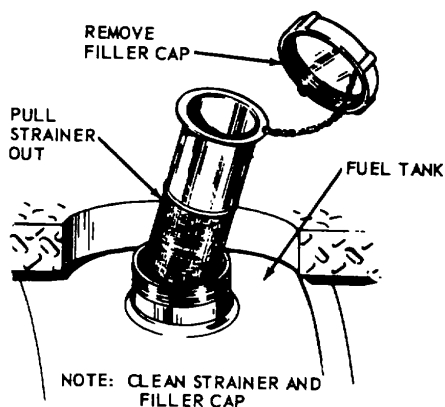

Figure 27. Carrier engine fuel tank service.

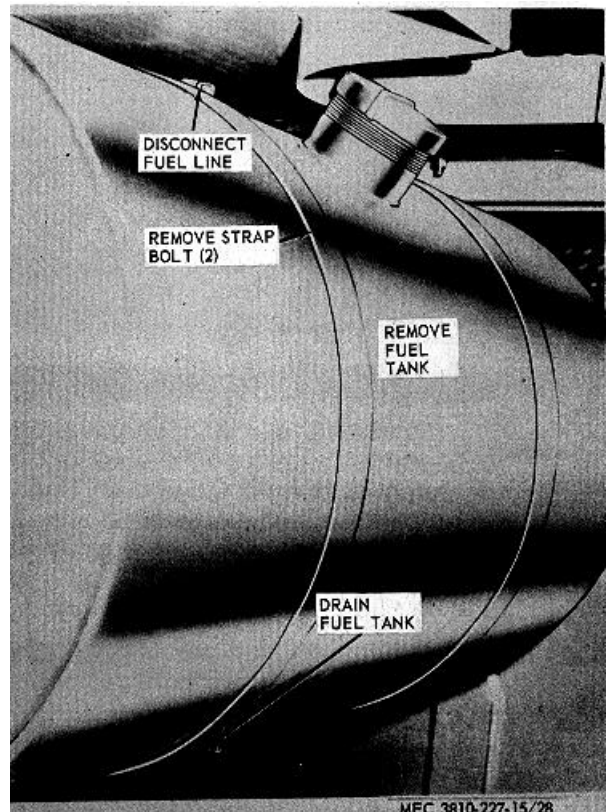

Figure 28. Carrier engine fuel tank, removal and installation.

b. *Adjustment.* Adjust the carburetor as instructed in figure 30.

c. *Removal.*

- (1) Remove air cleaner hose and flange (para. 84).
- (2) Remove the engine speed governor (para. 87).
- (3) Remove the carburetor as instructed in figure 31.

d. *Cleaning and Inspection.*

- (1) Clean all parts with an approved cleaning solvent and dry thoroughly.
- (2) Inspect all parts for excessive wear, improper operation, and other damage.
- (3) Replace a defective carburetor.

e. *Installation.*

- (1) Install the carburetor as shown in figure 31.
- (2) Install the governor (para. 87).

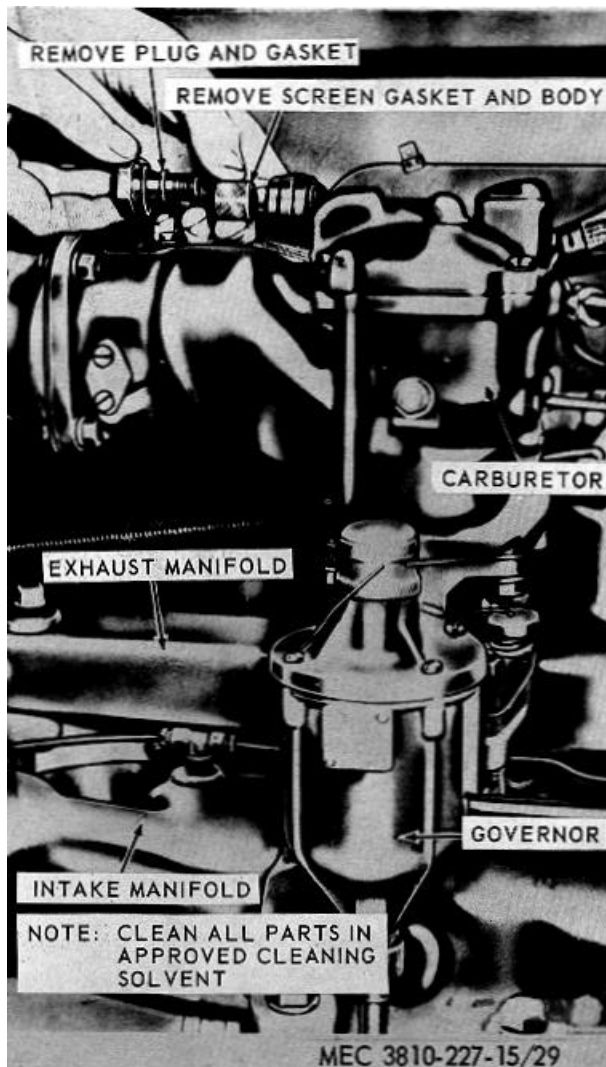

Figure 29. Carrier engine carburetor screen service.

(3) Install the flange and air cleaner hose (para. 84).

### 87. Engine Governor

a. *Removal.* Remove the governor as instructed in figure 32.

b. *Cleaning and Inspection.*

(1) Clean all parts with an approved cleaning solvent and dry thoroughly.

(2) Inspect all parts for damage or defective condition.

(3) Replace a defective governor.

c. *Installation and Adjustment.* Install and adjust the governor as illustrated in figure 82, so engine operates at 2,800 rpm at full throttle.

### 88. Fuel Pump

a. *Removal and Installation.* Remove and in-tall the carrier engine fuel pump as instructed in figure 33.

b. *Cleaning, Inspection, and Repair.*

(1) Clean all parts with an approved cleaning solvent and dry thoroughly.

(2) Inspect all parts for defective condition.

(3) Repair or replace damaged parts as necessary.

### 89. Accelerator Linkage and Controls

a. *Removal.* Tag, disconnect, and remove the carrier engine accelerator linkage and carburetor controls in numerical sequence as shown in figure 34.

b. *Cleaning, Inspection, and Repair.*

(1) Clean all parts with an approved cleaning solvent and dry thoroughly.

(2) Inspect all parts for defective condition.

(3) Repair or replace damaged parts as necessary.

c. *Installation.* Install and connect the carrier engine accelerator linkage in reverse order of the numerical sequence shown in figure 34.

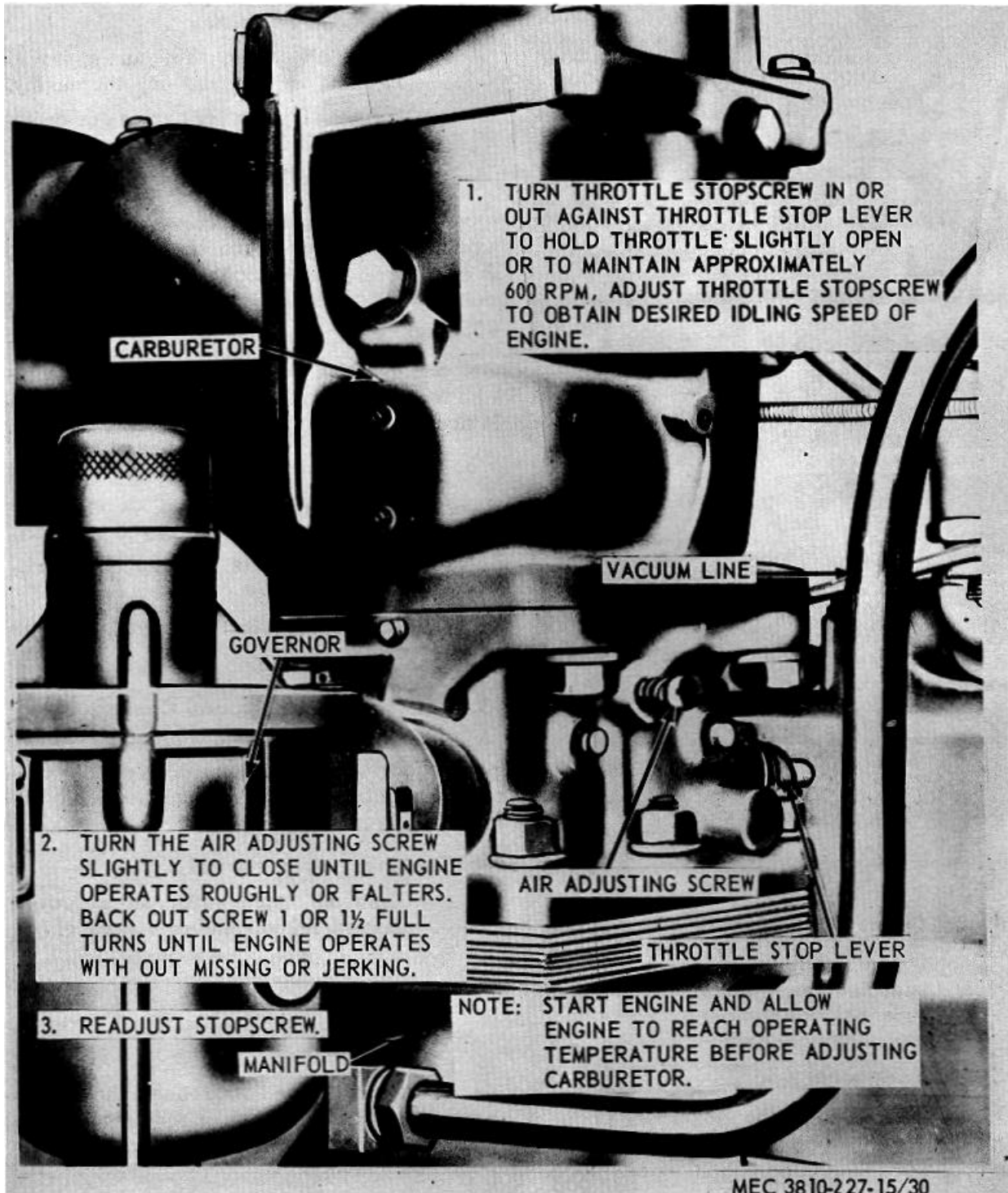

Figure 30. Carrier engine carburetor adjustment.

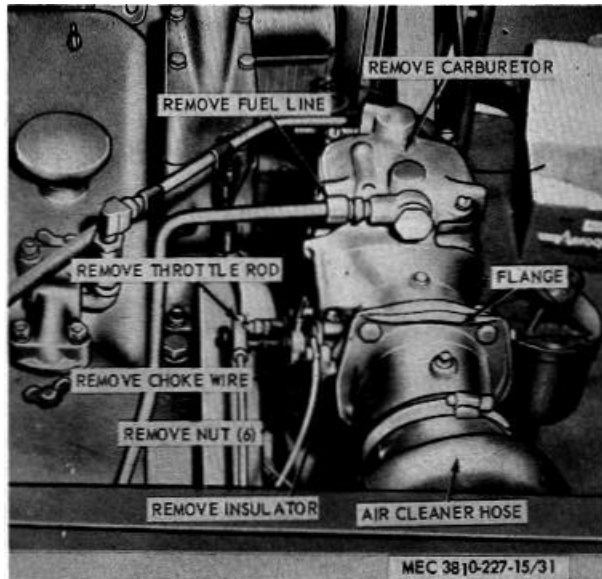

Figure 31. Carrier engine carburetor, removal and installation.

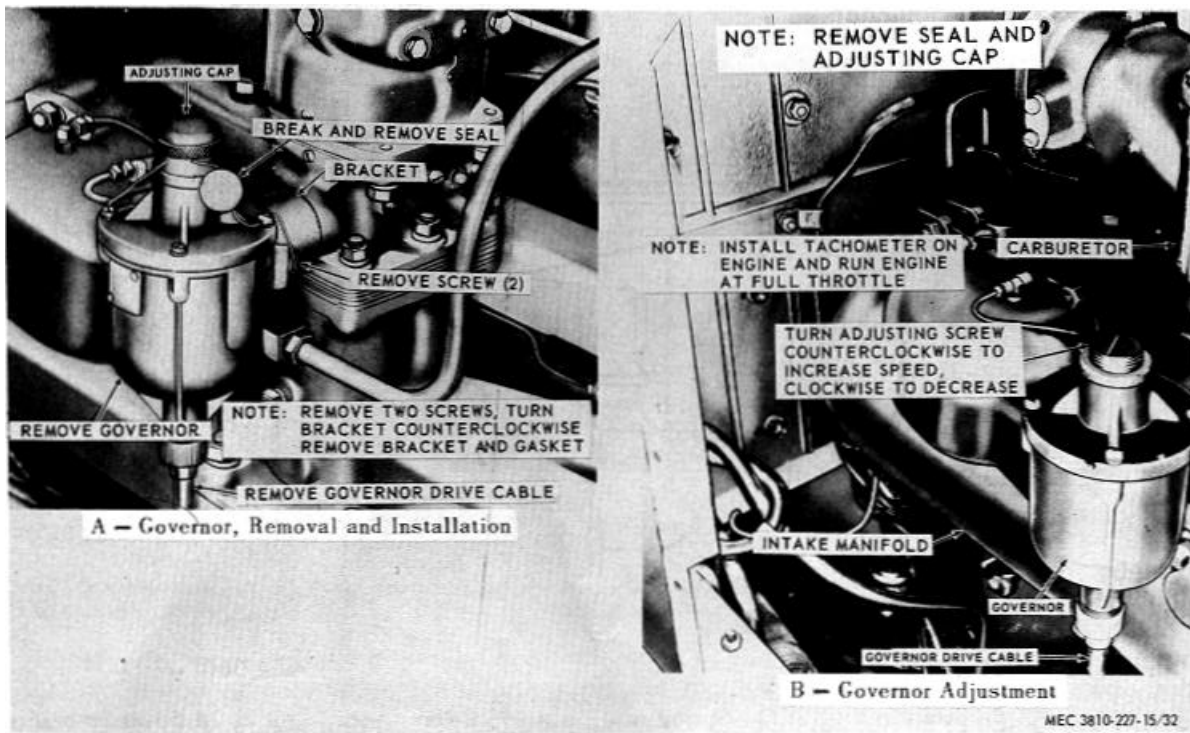

Figure 32. Carrier engine governor, removal, installation and adjustment.

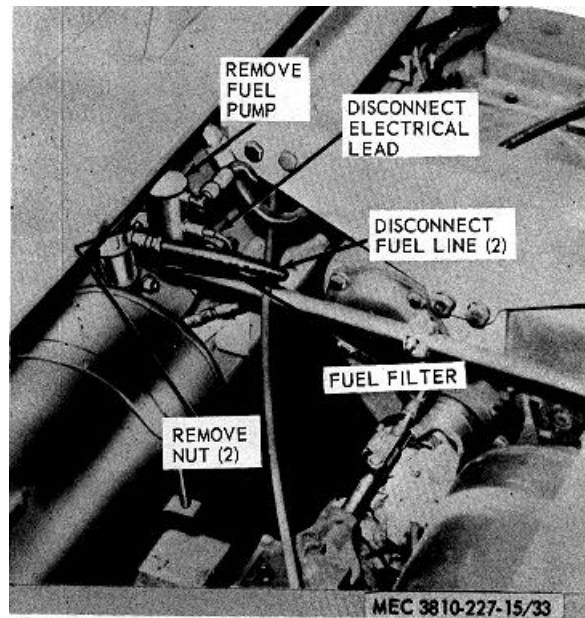
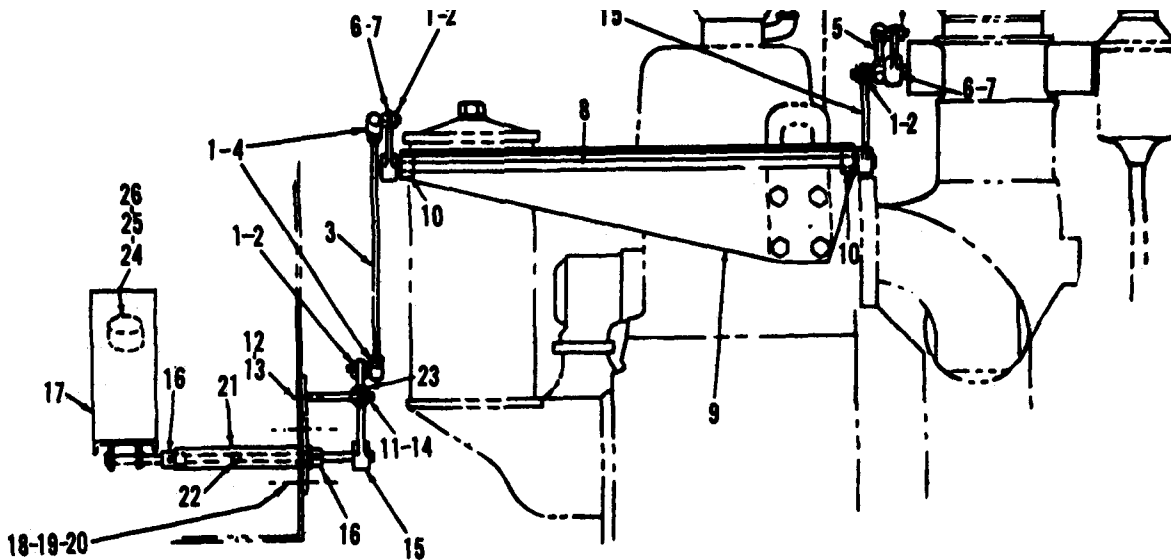

Figure 33. Carrier engine fuel pump, removal and installation.



MEC 3810-227-15/34

- |               |                 |                   |                      |                        |
|---------------|-----------------|-------------------|----------------------|------------------------|
| 1 Hex nut     | 6 Setscrew      | 11 Spring         | 16 Collar            | 21 Accelerator bracket |
| 2 Lockwasher  | 7 Linkage lever | 12 Hex nut        | 17 Accelerator pedal | 22 Lube fitting        |
| 3 Linkage rod | 8 Shaft         | 13 Capscrew       | 18 Hex nut           | 23 Throttle bracket    |
| 4 Ball joint  | 9 Bracket       | 14 Spring bracket | 19 Capscrew          | 24 Capscrew            |
| 5 Linkage rod | 10 Bushing      | 15 Linkage lever  | 20 Lockwasher        | 25 Lockwasher          |
|               |                 |                   |                      | 26 Pedal stop          |
- 
- |               |                 |                   |                      |                        |
|---------------|-----------------|-------------------|----------------------|------------------------|
| 1 Hex nut     | 6 Setscrew      | 11 Spring         | 16 Collar            | 21 Accelerator bracket |
| 2 Lockwasher  | 7 Linkage lever | 12 Hex nut        | 17 Accelerator pedal | 22 Lube fitting        |
| 8 Linkage rod | 8 Shaft         | 13 Capscrew       | 18 Hex nut           | 23 Throttle bracket    |
| 4 Ball joint  | 9 Bracket       | 14 Spring bracket | 19 Capscrew          | 24 Capscrew            |
| 5 Linkage rod | 10 Bushing      | 15 Linkage lever  | 20 Lockwasher        | 25 Lockwasher          |
|               |                 |                   |                      | 26 Pedal stop          |

Figure 34. Carrier engine accelerator linkage, removal and installation.

## Section VI. CRANE ENGINE FUEL SYSTEM

### 90. General

The fuel system consists of a 50-gallon fuel tank, fuel pump, carburetor, air cleaner, lines and fittings. A fuel line with shutoff cock connects the tank to a diaphragm-type fuel pump, mounted on the right-rear side of the engine block. A fuel line connects to an updraft-type carburetor, mounted on the right side of the engine. The oil-bath type air cleaner is connected to the bottom of the carburetor with a hose. During operation, clean air passes from the air cleaner to the carburetor. At the carburetor the air picks up a spray of gasoline and the gasoline-air mixture is drawn into the cylinders where it is ignited by the spark plugs.

### 91. Engine Air Cleaner

a. *Removal and Installation.* Remove and install the air cleaner as shown in figure 35.

b. *Disassembly.* Disassemble the air cleaner as illustrated in figure 36.

c. *Cleaning, Inspection, and Repair.*

(1) Clean the air cleaner as instructed in figure 20.

(2) Inspect all parts for fractures and other damage.

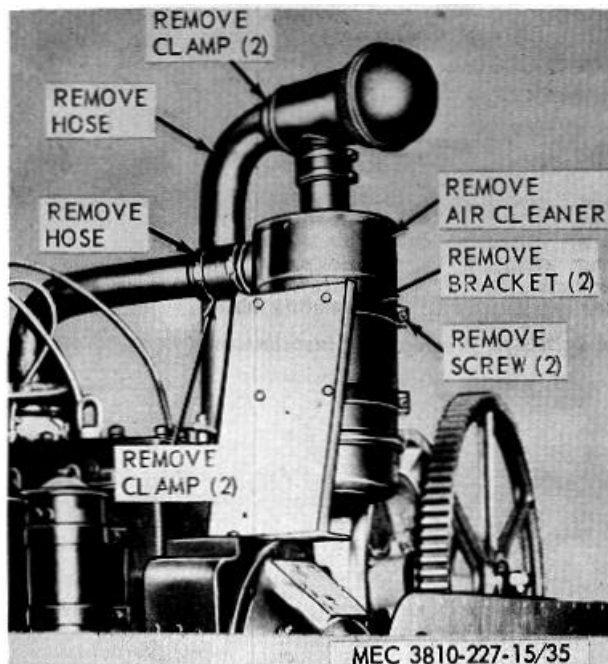
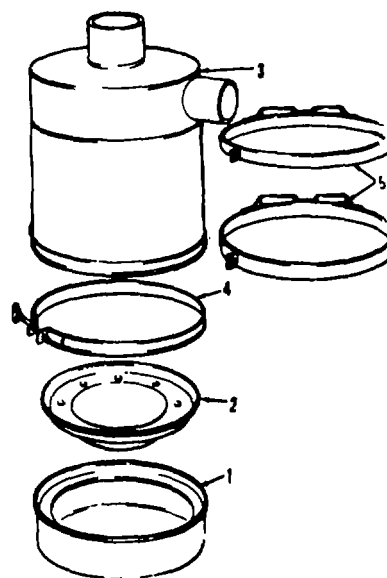

Figure 35. Crane engine air cleaner, removal and installation.



MEC 3810-227-15/36

- |                 |                    |
|-----------------|--------------------|
| 1 Cup assembly  | 4 Clamp assembly   |
| 2 Inner cup     | 5 Mounting bracket |
| 3 Body assembly |                    |

Figure 36. Crane engine air cleaner, exploded view.

(3) Repair or replace damaged parts as necessary.

d. *Reassembly.* Reassemble the air cleaner as illustrated on figure 36.

### 92. Fuel Tank, Lines, and Fittings

a. *Service.* Service the crane engine fuel tank as instructed in figure 27.

b. *Removal and Installation.* Remove and install the fuel tank, lines and fittings as instructed in figure 37.

c. *Cleaning, Inspection, and Repair.*

(1) Clean all parts with an approved cleaning solvent.

(2) Inspect all parts for defective condition.

(3) Repair or replace damaged parts as necessary. Replace all gaskets.



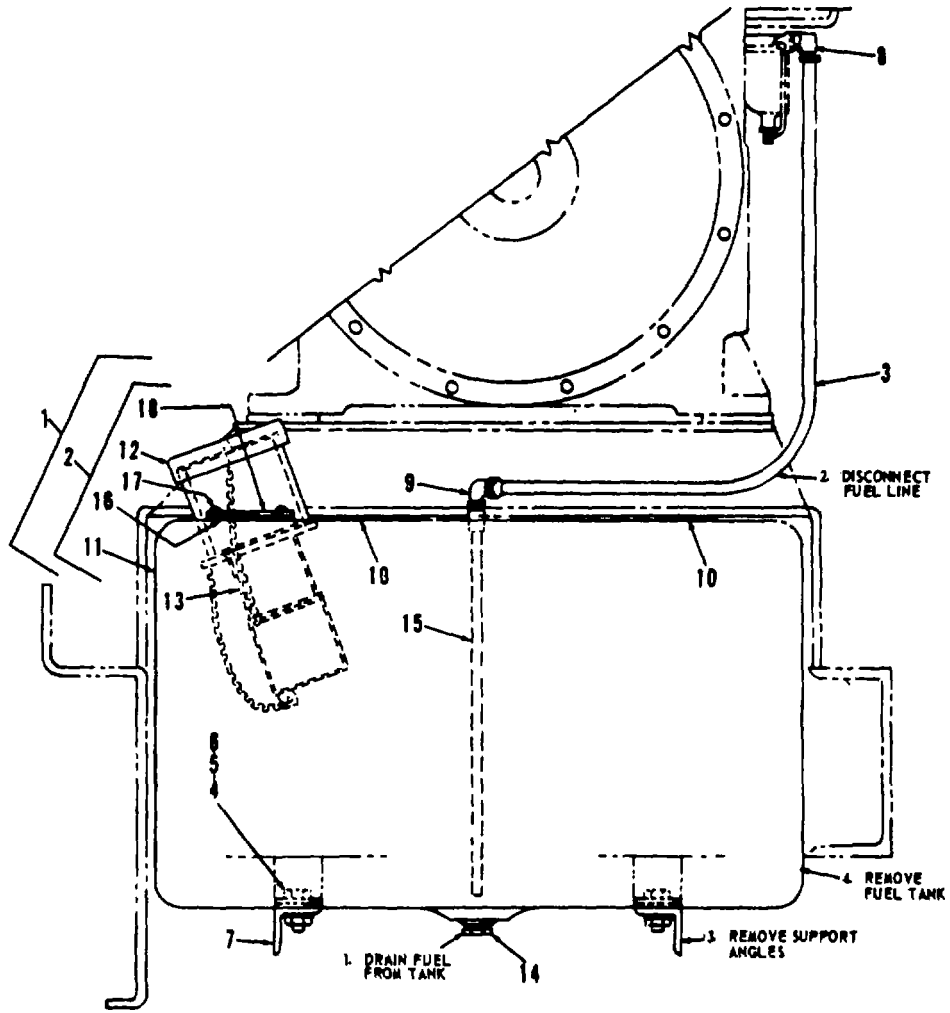

MEC 3810-227-15/37

- |                          |                 |                 |
|--------------------------|-----------------|-----------------|
| 1 Fuel tank installation | 7 Angle         | 18 Strainer     |
| 2 Fuel tank assembly     | 8 Elbow         | 14 Drain plug   |
| 3 Fuel line              | 9 Elbow         | 16 Suction tube |
| 4 Capscrew               | 10 Sponge strip | 16 Gasket       |
| 5 Nut                    | 11 Fuel tank    | 17 Screw        |
| 6 Lockwasher             | 12 Filler cap   | 18 Sending unit |

Figure 37. Crane engine fuel tank, lines and fittings, removal and installation.

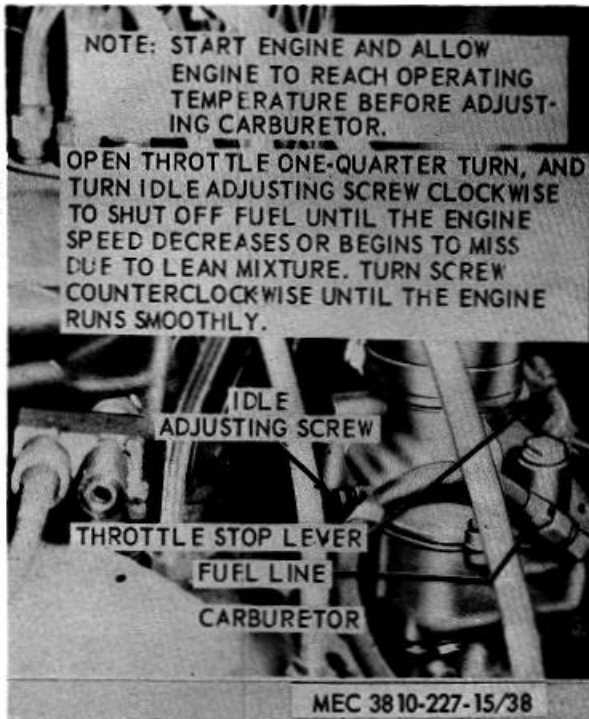

Figure 38. Crane engine carburetor adjustment.

### 93. Carburetor

a. *Description.* The carburetor used on the crane engine is an updraft, single venturi designed carburetor. The mixture of the fuel-air for low speed idling is controlled by the adjusting needle. The main adjusting screw controls the amount of fuel delivered for high speed engine operation.

b. *Adjustment.* Adjust the carburetor as instructed in figure 38.

c. *Removal and Installation.* Remove and install the carburetor as instructed in figure 89.

d. *Cleaning and Inspection.*

(1) Clean the carburetor with an approved cleaning solvent.

(2) Inspect the carburetor for wear, improper operation, and other damage.

(3) Replace defective carburetor.

### 94. Engine Governor

a. *Adjustment.*

(1) Start the engine and allow it to operate

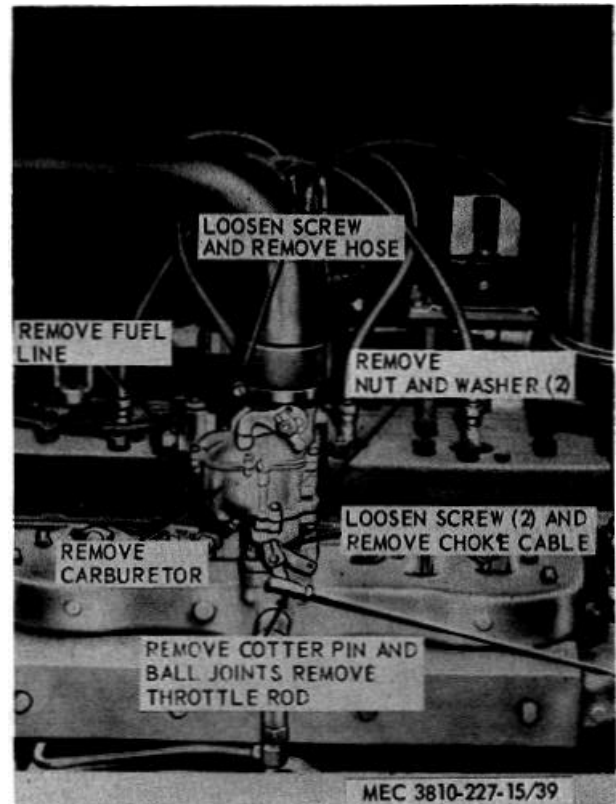

Figure 39. Crane engine carburetor, removal and installation.

until it reaches normal operating temperature.

(2) Loosen locknut on governor adjusting screw (fig. 40) and back out on the adjusting screw several turns to make sure it does not affect the engine speed.

(3) Use a tachometer and check the engine speed with the engine pulling its rated load. If the desired engine speed (1800 rpm) cannot be obtained, increase or decrease the tension of the governor spring by loosening the adjusting nut and lowering or raising the adjusting eyebolt to obtain desired speed range.

(4) Secure the adjusting eyebolt in place with the locknut.

(5) If the governor surges at no-load speed after spring tension is adjusted, turn the adjusting capscrew in unit surge is eliminated; secure with locknut.

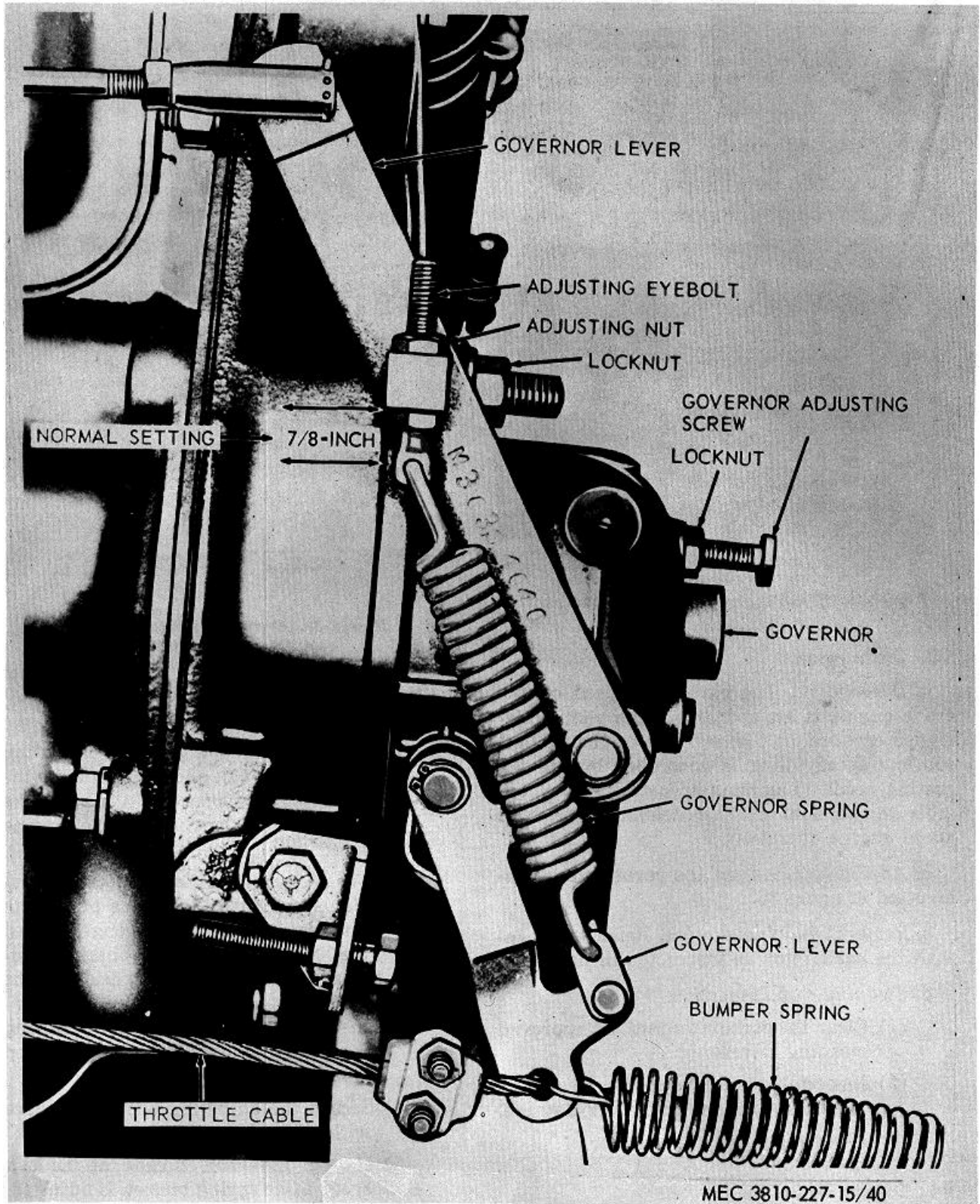

MEC 3810-227-15/40

Figure 40. Crane engine governor, adjustment.

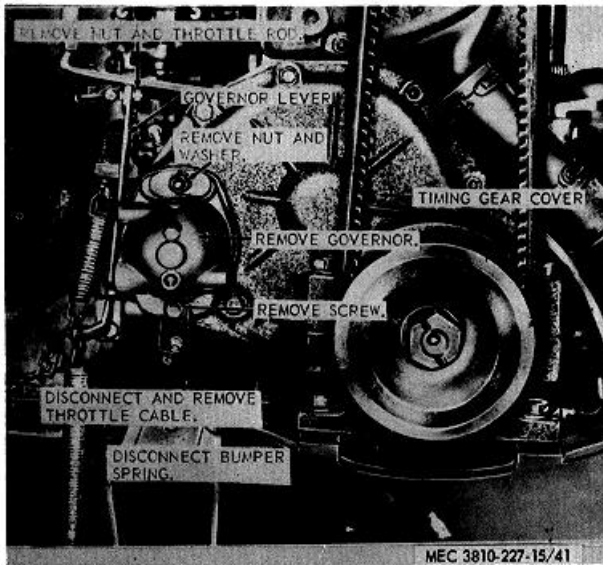

**Figure 41. Crane engine governor, removal and installation.**

*b. Removal and Installation.* Remove and install the crane governor as instructed in figure 41.

*c. Cleaning and Inspection.*

(1) Clean the governor with an approved cleaning solvent and dry thoroughly.

(2) Inspect the governor for cracks, breaks, proper operation and other damage.

(3) Replace a defective governor assembly.

#### **95. Fuel Pump and Sediment Bowl**

*a. Service.* Service the crane engine fuel sediment bowl and screen as instructed in figure 42.

*b. Removal and Installation.* Remove the fuel pump as shown in figure 43.

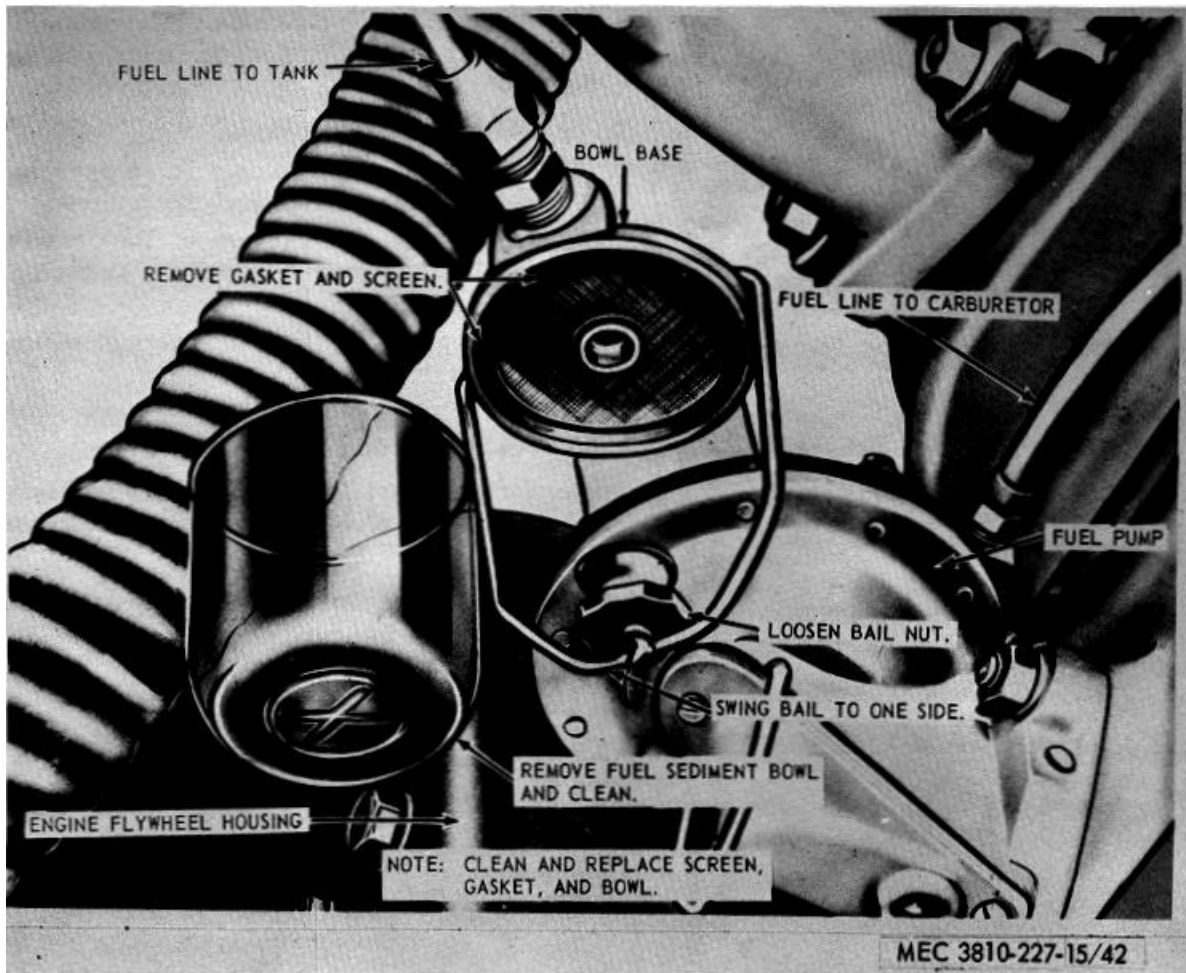
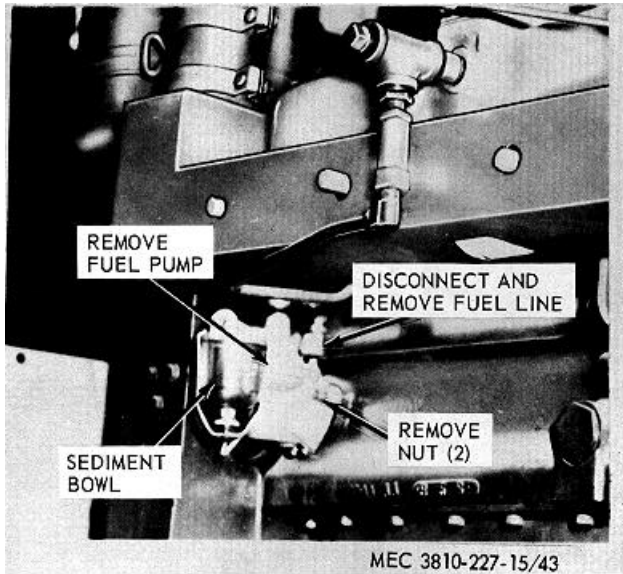

Figure 42. Crane engine fuel sediment bowl and screen service.



**Figure 43. Crane engine fuel pump, removal and installation.**

*c. Cleaning and Inspection.*

- (1) Clean the fuel pump with an approved cleaning solvent.
- (2) Inspect the fuel pump for breaks, proper operation and other damage.
- (3) Replace a defective fuel pump.

**96. Throttle Control and Choke Control**

*a. Removal and Installation.* Remove and install throttle and choke control as shown in figure 44.

*b. Cleaning and Inspection.*

- (1) Clean the throttle control with an approved cleaning solvent.
- (2) Inspect for breaks, kinks or other damage.
- (3) Replace a defective throttle control.

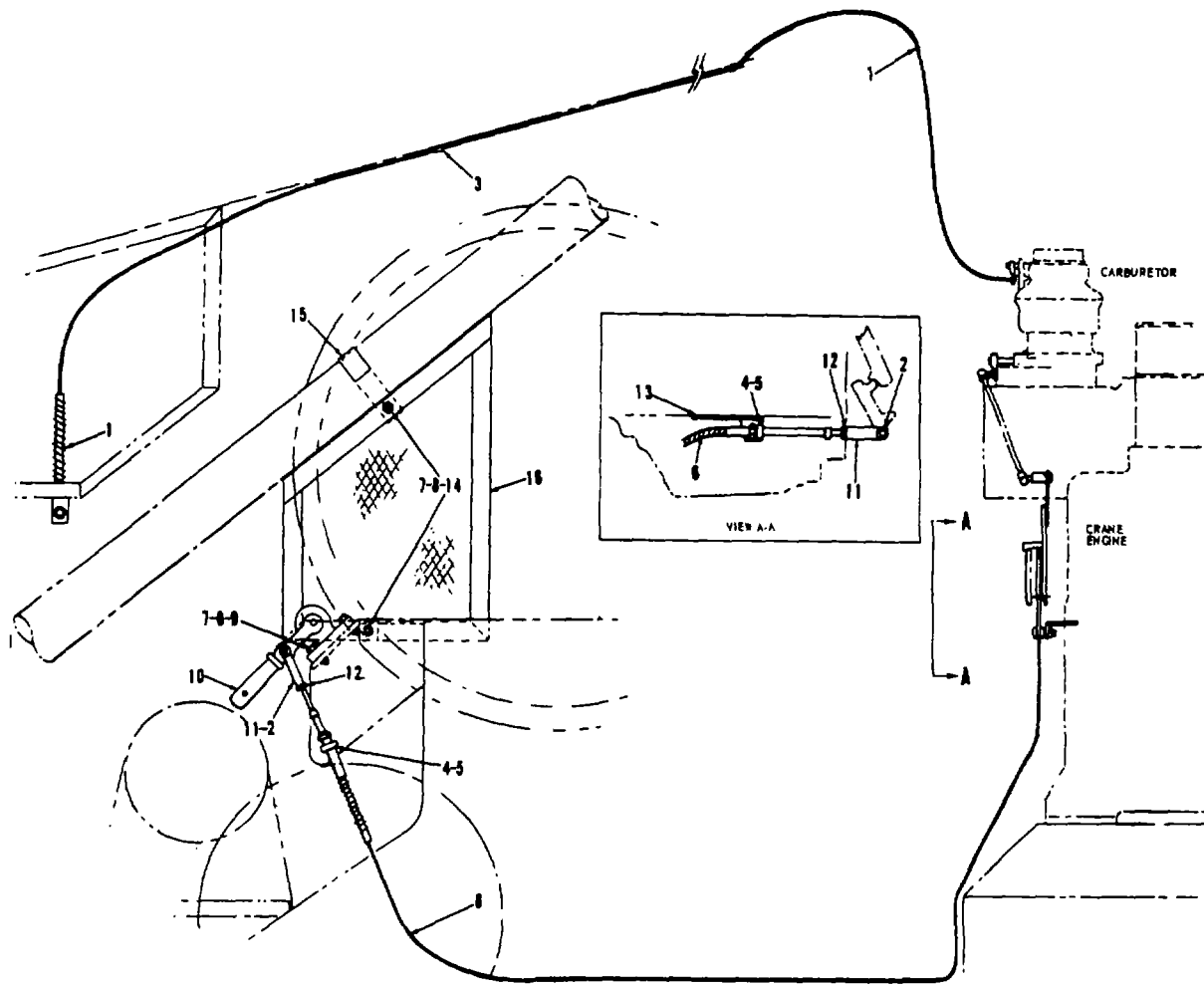

MEC 3810-227-15/44

- |                    |                    |                   |             |
|--------------------|--------------------|-------------------|-------------|
| 1 Choke control    | 6 Hook bolt        | 9 Capscrew        | 13 Support  |
| 2 Clevis pin       | 6 Throttle control | 10 Throttle lever | 14 Capscrew |
| 3 Clip             | 7 Hex nut          | 11 Clevis         | 15 Clamp    |
| 4 Self-locking nut | 8 Lockwasher       | 12 Jam nut        | 16 Guard    |

Figure 44. Throttle and choke control assembly.

## Section VII. CARRIER ENGINE ELECTRICAL SYSTEMS, CONTROLS AND INSTRUMENTS

### 97. General

The electrical system is a 24-volt system and consists of two 12-volt batteries, a generator, generator regulator, starter and starter solenoid, distributor, six spark plugs, lighting system, heater control system, panel switches and gages, and the necessary connecting wires and cables. Electrical energy to crank the engine flows from the batteries to the starter solenoid and starter. The

generator and generator regulator supply the current to keep the battery at the proper charge. The distributor and coil supply the electrical power to the engine spark plugs. Current flows from the batteries to the panel switches which control the lights and electrical accessory items. For proper removal and installation of all electrical wiring on the carrier refer to the wiring diagram, figure 3.

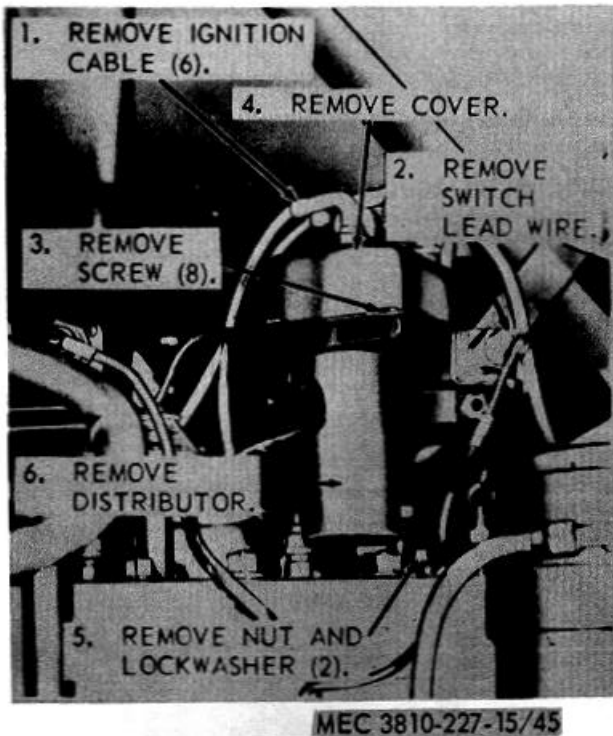

Figure 45. Distributor, removal and installation.

## 98. Distributor

a. *Removal.* Remove the distributor as shown in figure 45.

### Note.

**Before removing the distributor for reassembly, place identification marks on the distributor housing in relation to the distributor rotor.**

b. *Cleaning, and Inspection.*

- (1) Clean the distributor with an approved cleaning solvent and dry thoroughly.
- (2) Inspect the distributor for cracks, breaks, and other damage.
- (3) Replace a defective distributor.
- (4) Lubricate the distributor (LO 5-3810-227-15).

c. *Installation.* Refer to the identification marks placed on the distributor housing and install the distributor as illustrated in figure 45.

## 99. Distributor Points, Coil, Condenser, Resistor, and Rotor Cap

a. *Removal.*

- (1) Remove the distributor (para. 98).
- (2) Disassemble the distributor as illustrated in figure 46.

b. *Cleaning, Inspection and Repair.*

- (1) Clean all parts with an approved cleaning solvent and dry thoroughly.
- (2) Inspect the points for excessive burning, pits, and other damage. Replace defective points.
- (3) Using a coil and condenser tester, test the coil and condensers. Replace defective coil, condensers, or resistor.

c. *Coil Testing.*

- (1) Test with a test lamp as follows: Test the coil for open or grounded circuits by using a test lamp. Check the primary circuit by placing the test points on the two primary terminals. If the lamp does not light, the primary circuit is open. Check the secondary circuit by placing one test point in the high tension terminal and the second test point on one of the primary terminals. The lamp will not light, but sparks will be noted as the test points are rubbed over the terminals if the secondary winding is not open. If no sparks occur the secondary is open.
- (2) Test spark gap with a testing instrument as follows: Attach the leads from the testing instrument to the two primary terminals. Turn the distributor so the points will open and close to obtain a reading on the meter. When an instrument is used, test another coil which is known to be good. The two coils should have the same reading on the meter.

### Note.

**Do not touch the test instrument to the unit as the case is internally grounded and a faulty reading will occur.**

d. *Reassembly and Installation.*

- (1) Reassemble the distributor in the reverse order illustrated in figure 46.
- (2) Adjust the points as instructed in figure 46.
- (3) Lubricate the distributor (LO 5-3810-227-15).
- (4) Install the distributor (para. 98).

e. *Engine Timing.*

- (1) Loosen screw and raise cover (fig. 47).
- (2) Disconnect spark plug cable from



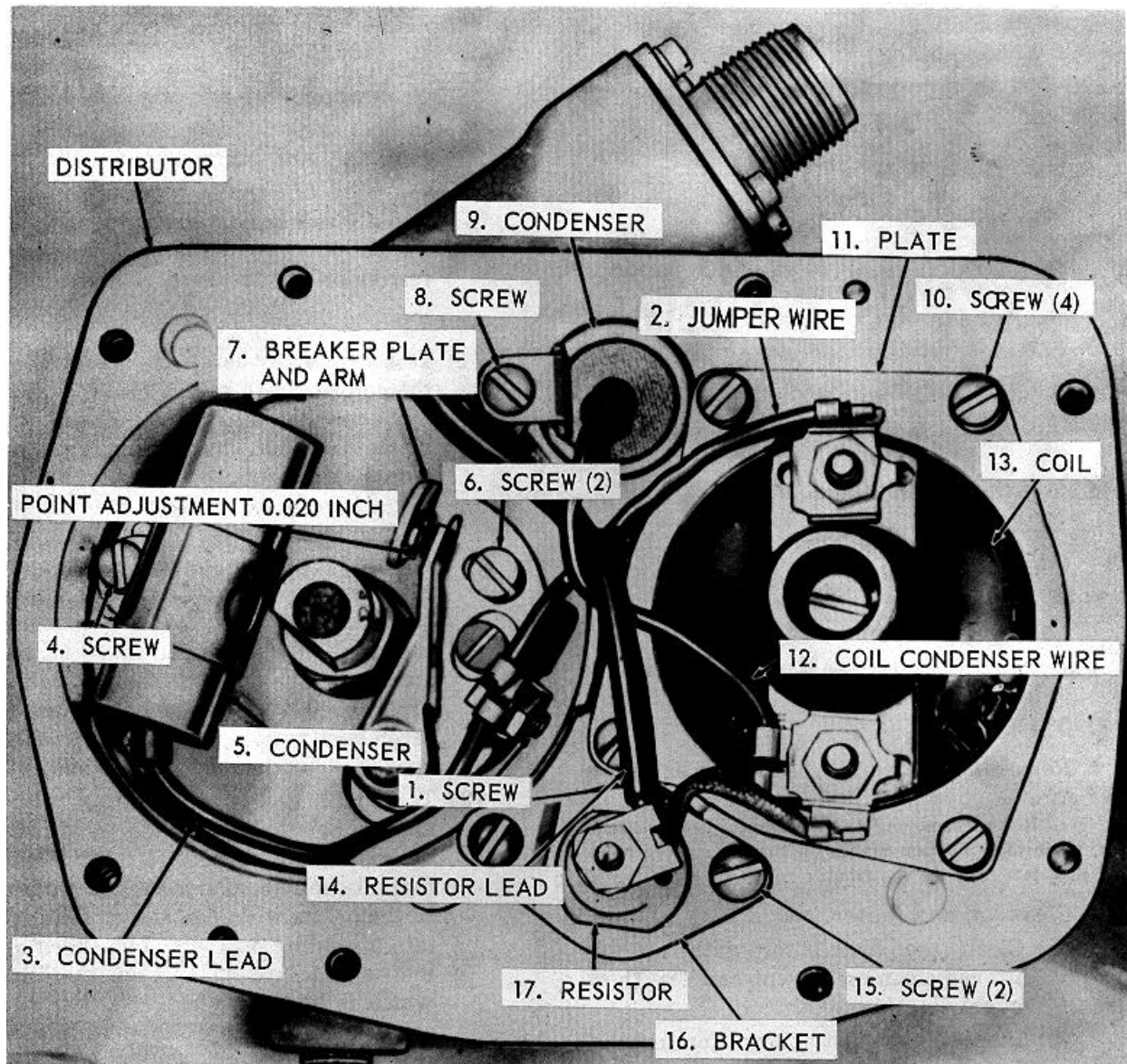

MEC 3810-227-15/46

**Figure 46. Distributor, coil, points, condenser, and resistor, removal, adjustment and installation.**

- spark plug installed in number 1 cylinder.
- (3) Connect a neon timing light between number 1 spark plug and cable.
- (4) Loosen the distributor mounting screws and start the engine.
- (5) Hold the timing light directly in front of the flywheel opening in the flywheel housing.
- (6) Rotate the distributor in either direction until the timing mark aligns with the center hole in the flywheel housing. Tighten the distributor mounting screws. Repeat adjustment as necessary.

- (7) Stop the engine, disconnect the neon light, and connect the spark cable to the spark plug.
- (8) Close the cover and tighten the screw (fig. 47).

## 100. Spark Plugs and Cables

### a. Removal.

- (1) Remove all dirt and foreign matter

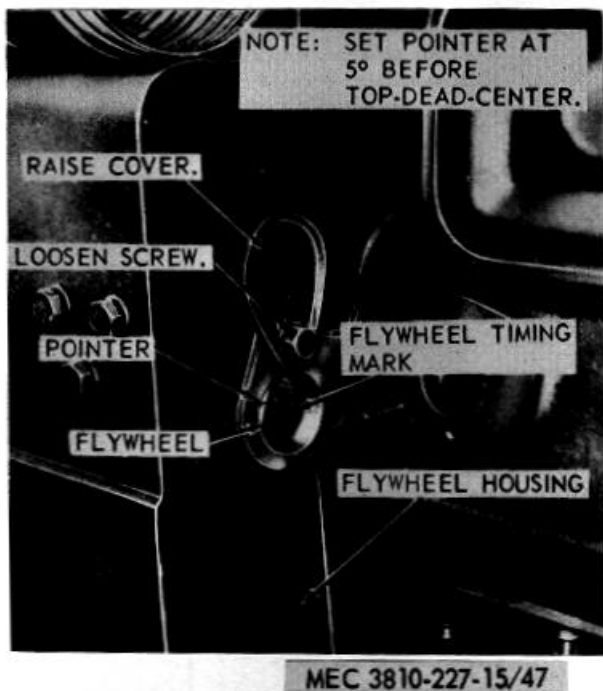

Figure 47. Engine flywheel timing marks.

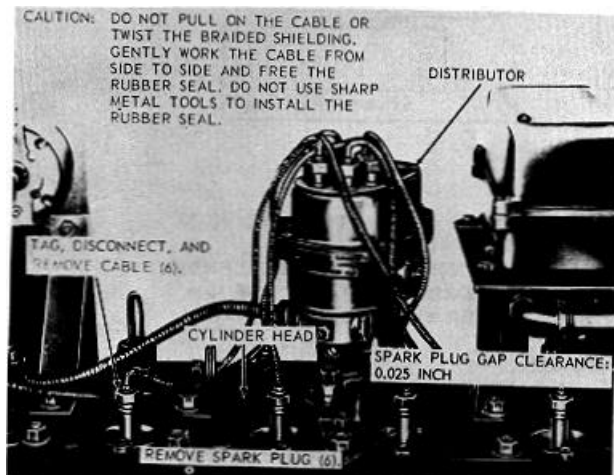

Figure 48. Spark plugs and cables, removal and installations

from the cylinder head around the spark plug openings.

- (2) Remove the cables and spark plugs as instructed in figure 48.

*b. Cleaning and Inspection.*

- (1) Clean the spark plugs and cables with a lint-free cloth dampened with an approved cleaning solvent and dry thoroughly.

Clean the spark plug points with an approved spark plug cleaning machine.

- (2) Inspect the insulators for chips and cracks. Replace plugs having defective insulators.
- (3) Inspect the electrodes for burns, pits, and alignment. Replace defective plugs.

**Note.**

**The outside or grounded electrode must be directly lined with the inside or insulated electrode.**

- (4) Inspect the spark plug cables for corrosion, frayed or broken insulation or shielding and proper connection. Replace defective cables.

*c. Adjustment.* Place a feeler gage between the center electrode and the ground electrode of the spark plug. Set the clearance by bending the ground electrode.

**Note.**

**Spark plug clearance for crane engine is 0.035 inch for resistor type plugs and 0.025 inch for standard plugs.**

**Note.**

**Do not damage the insulation surrounding the center electrode.**

*d. Test.* Test the spark plugs with an approved testing machine. Replace all defective plugs.

*e. Installation.* Install the spark plugs and cables as illustrated on figure 48.

**101. Starter Solenoid**

*a. Test.* Test the solenoid and starter assembly as instructed on figure 49.

*b. Removal.* Remove the starter solenoid assembly as instructed on figure 60.

*c. Cleaning and Inspection.*

- (1) Clean the starter solenoid with a cloth dampened with an approved cleaning solvent.
- (2) Inspect the solenoid for proper operation and other damage. Replace defective solenoid.
- (3) Inspect the wiring for frayed, broken, or worn conditions. Replace wiring as necessary.

*d. Installation.* Install the starter solenoid as illustrated on figure 50.

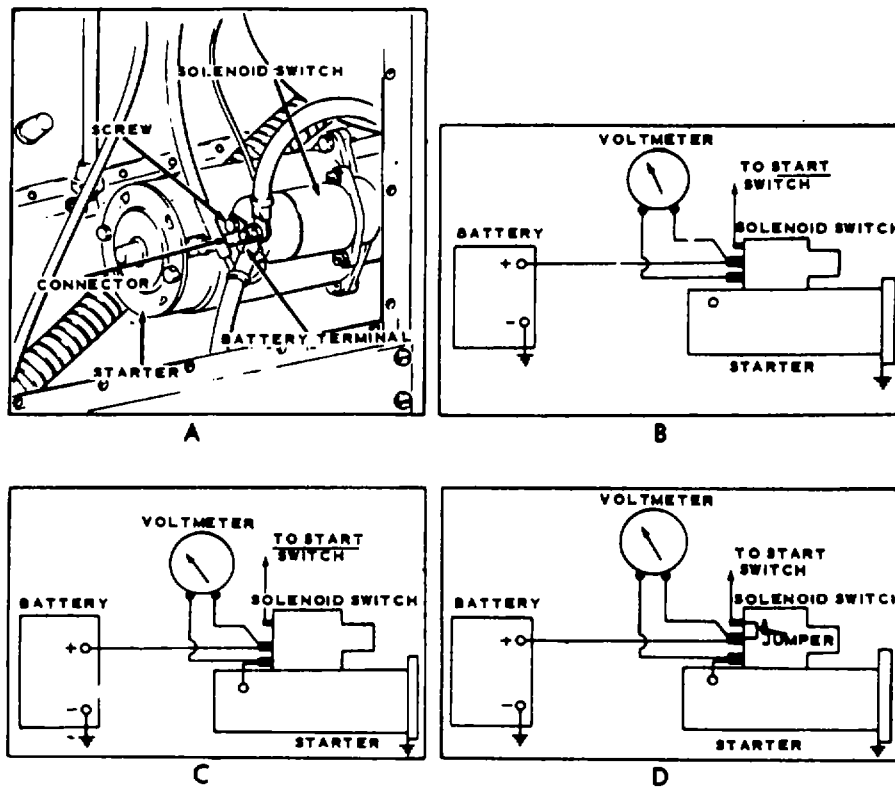

- STEP 1. DETERMINE THAT BATTERY IS FULLY CHARGED AND THAT ALL BATTERY AND STARTER CABLES ARE SERVICEABLE AND PROPERLY INSTALLED.
- STEP 2. REMOVE SCREW AND INSULATE SOLENOID-TO-STARTER CONNECTOR FROM SOLENOID SWITCH TERMINAL. CONNECT VOLTMETER AS SHOWN IN B ABOVE. IF VOLTAGE IS INDICATED, SOLENOID SWITCH IS DEFECTIVE AND STARTER WITH SOLENOID SWITCH MUST BE REPLACED.
- STEP 3. INSTALL THE SOLENOID-TO-STARTER CONNECTOR.
- STEP 4. CONNECT VOLTMETER AS SHOWN IN C ABOVE. IF BATTERY VOLTAGE (24 VOLTS) IS NOT INDICATED, THE STARTER IS DEFECTIVE AND MUST BE REPLACED.
- STEP 5. MOMENTARILY CONNECT A JUMPER AS SHOWN IN D ABOVE. THE VOLTMETER READING SHOULD DROP TO ZERO AND STARTER SHOULD CRANK ENGINE. IF VOLTMETER READING DOES NOT DROP TO ZERO, SOLENOID SWITCH IS DEFECTIVE AND STARTER WITH SOLENOID SWITCH MUST BE REPLACED. IF VOLTMETER READING DROPS TO ZERO BUT STARTER FAILS TO CRANK ENGINE, STARTER IS DEFECTIVE AND MUST BE REPLACED.

- A - Starter and solenoid, installed view
- B - Solenoid test wiring diagram
- C - Starter test wiring diagram
- D - Jumper test diagram

MEC 3810-227-15/49

Figure 49. Starter and solenoid test wiring diagram.

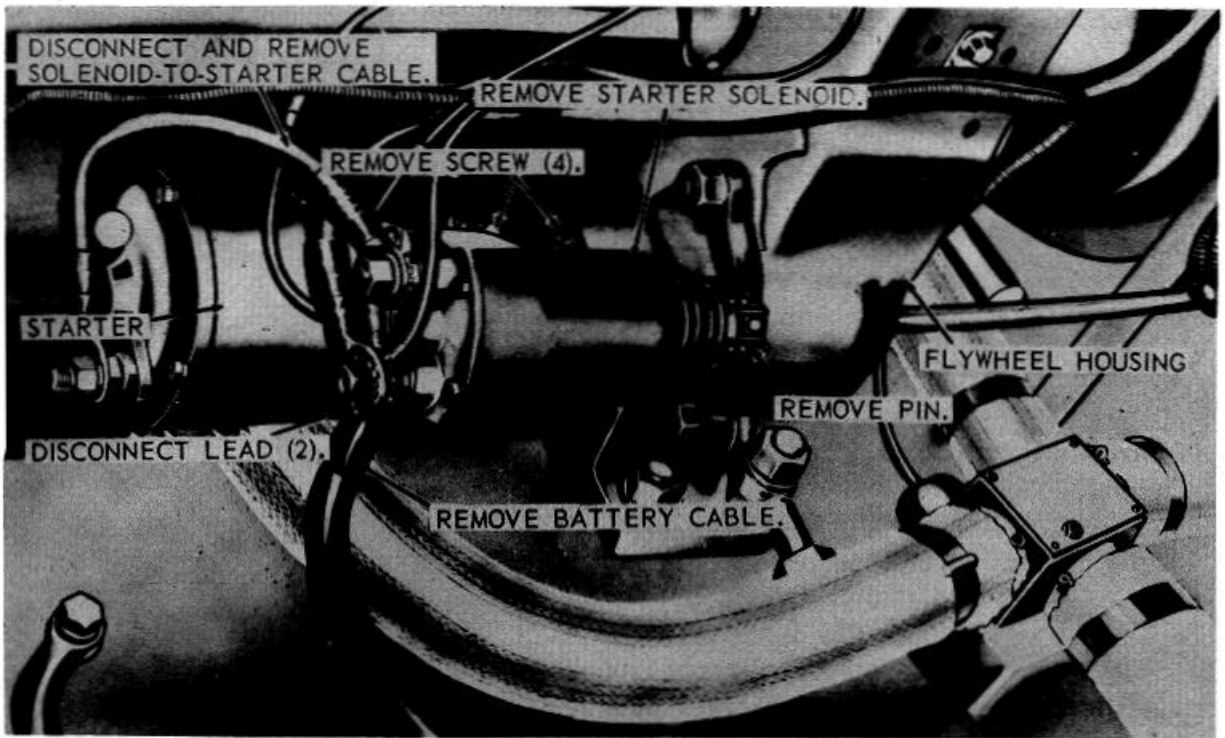

A - Starter Solenoid, Installed View.

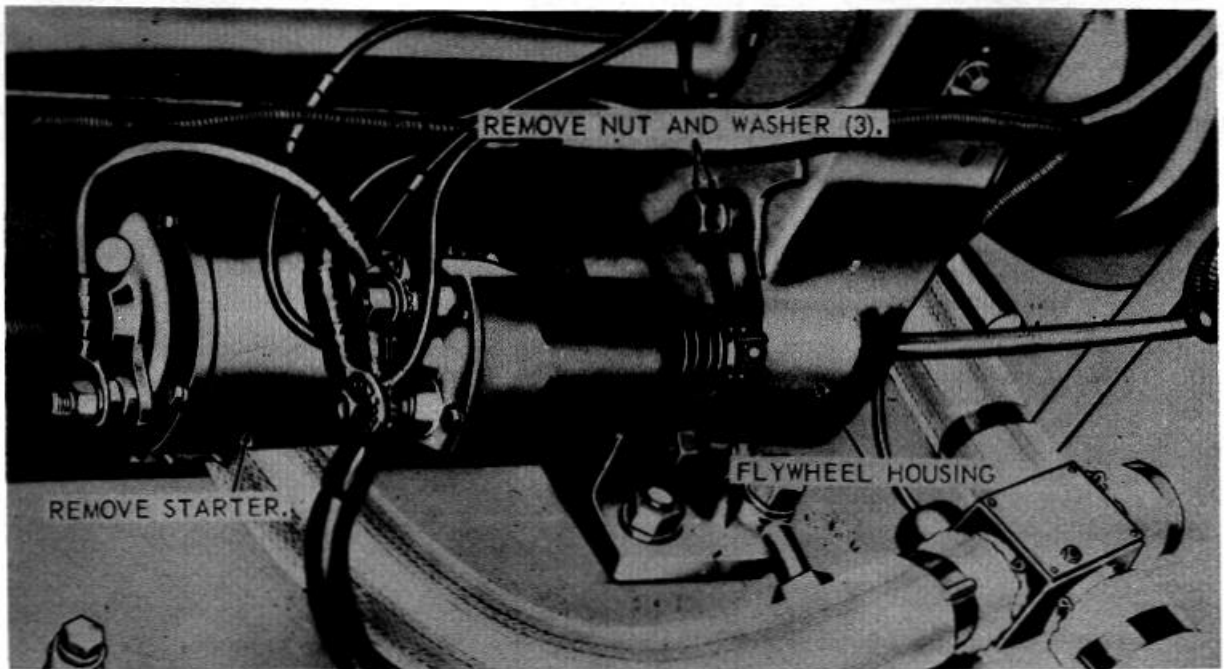

B - Starter, Installed View.

MEC 3810-227-15/50

Figure 50. Solenoid and starter, removal and installation.

## 102. Starter Assembly

### a. Removal.

- (1) Remove the starter solenoid (para. 101).
- (2) Remove the starter as instructed on figure 50.

### b. Cleaning and Inspection.

- (1) Clean the starter assembly with a cloth dampened with an approved cleaning solvent.
- (2) Rotate the drive pinion to see that the armature turns freely and does not bind.
- (3) Remove the cover band and inspect the brushes. If brushes are worn to less than 1/2 inch, replace brushes.
- (4) Inspect starter assembly for proper operation, wear, and other damage. Replace defective starter.
- (5) Inspect the commutator for pits, burns and other damage. If commutator is defective replace starter.

c. *Installation.* Install the starter assembly as illustrated in figure 50.

### d. Brush Replacement.

#### (1) Removal.

(a) Remove the starter as instructed on figure 50.

(b) Remove the cover band.

(c) Remove the brushes as instructed on figure 51.

#### (2) Installation.

(a) Install the brushes as illustrated on figure 51. Fit brushes to commutator.

(b) Install the band cover.

(c) Install the starter as illustrated on figure 50.

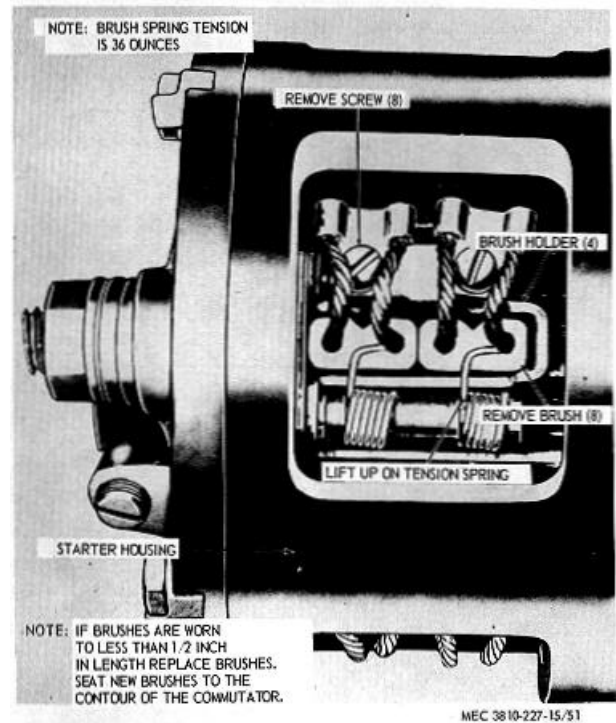

Figure 51. Starter brush, replacement.

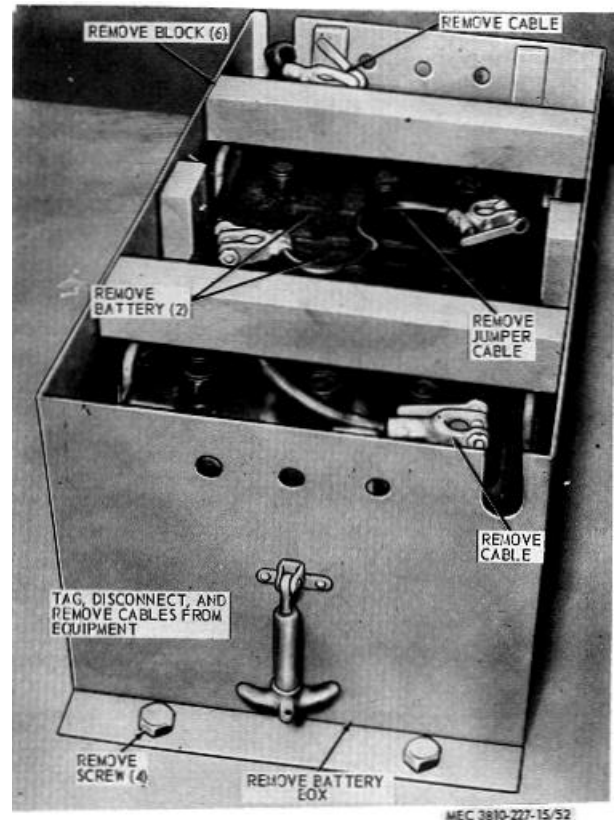
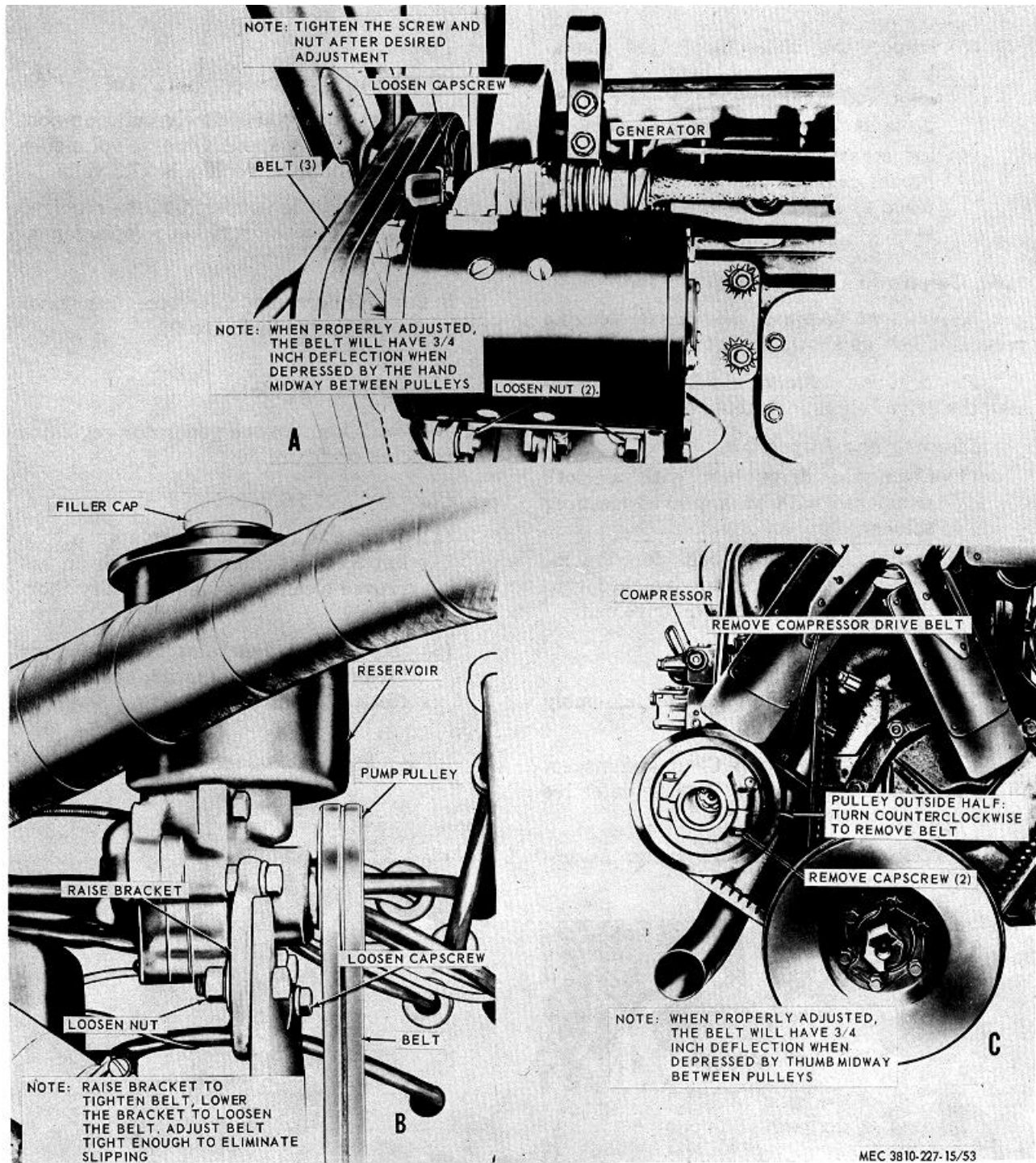

Figure 52. Batteries, cables, and battery box, removal and installation.



**Figure 53. Carrier engine generator belt, adjustment, removal and installation.**

*b. Removal and Installation.* Remove and install the batteries, cables and battery box as instructed in figure 52.

*c. Cleaning, Inspection and Repair.*

- (1) Clean the batteries, cables, and battery box with an approved cleaning solvent and dry thoroughly.
- (2) Inspect the batteries for cracks, leaks or other damage. Replace a defective battery as necessary.

- (3) Inspect the cables for frayed insulation, broken wires, bent or broken lugs, and other damage. Repair or replace damaged cables as necessary.
- (4) Inspect the battery box for cracks, breaks or other damage. Repair or replace a damaged battery box as necessary.

**104. Generator Drive Belt**

- a. *Adjustment.* Adjust the carrier engine generator belt as shown in figure 53.
- b. *Removal and Installation.* Remove and install the drive belt as instructed in figure 53.
- c. *Cleaning and Inspection.*
  - (1) Clean the drive belt with a cloth dampened with an approved cleaning solvent.
  - (2) Inspect the drive belt for cracks, breaks, and frayed or stretched condition. Replace defective drive belt.

**105. Generator Assembly**

- a. *Removal.* Remove the generator assembly as instructed on figure 54.
- b. *Cleaning and Inspection.* Clean and inspect the generator and mounting. Replace defective generator and mounting.
- c. *Installation.* Install the generator assembly as illustrated on figure 54.

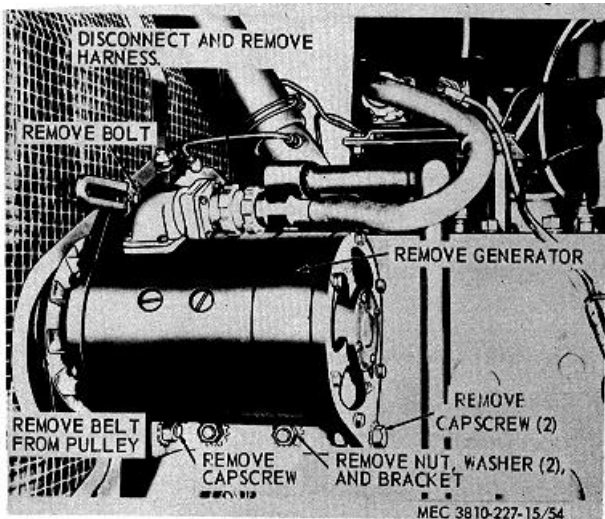
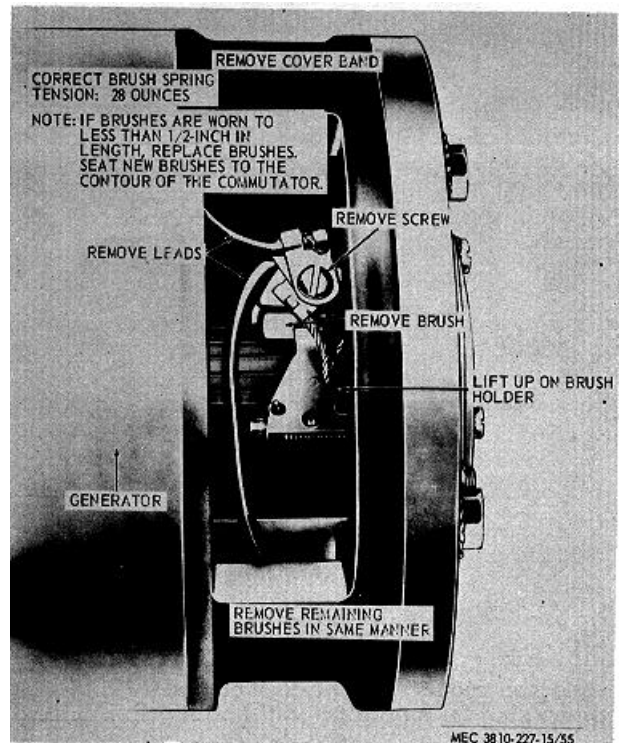

**Figure 54. Generator assembly, removal and installation.**

- d. *Test.*
  - (1) Connect voltmeter (para. 106).
  - (2) Start engine and slowly build up rpm to operating speed. Observe voltmeter. The minimum voltage is 27.5 volts.
  - (3) If voltage is not built up to required value, generator is bad; replace generator.
- e. *Brush Replacement.* Replace generator brushes as instructed in figure 66.

**106. Generator Regulator**

- a. *Removal.* Remove the generator regulator as instructed on figure 56.
- b. *Cleaning and Inspection.*
  - (1) Clean the generator regulator with a lint-free cloth dampened with an approved cleaning solvent and dry thoroughly.
  - (2) Inspect the generator regulator for breaks and other damage. Replace defective generator regulator.



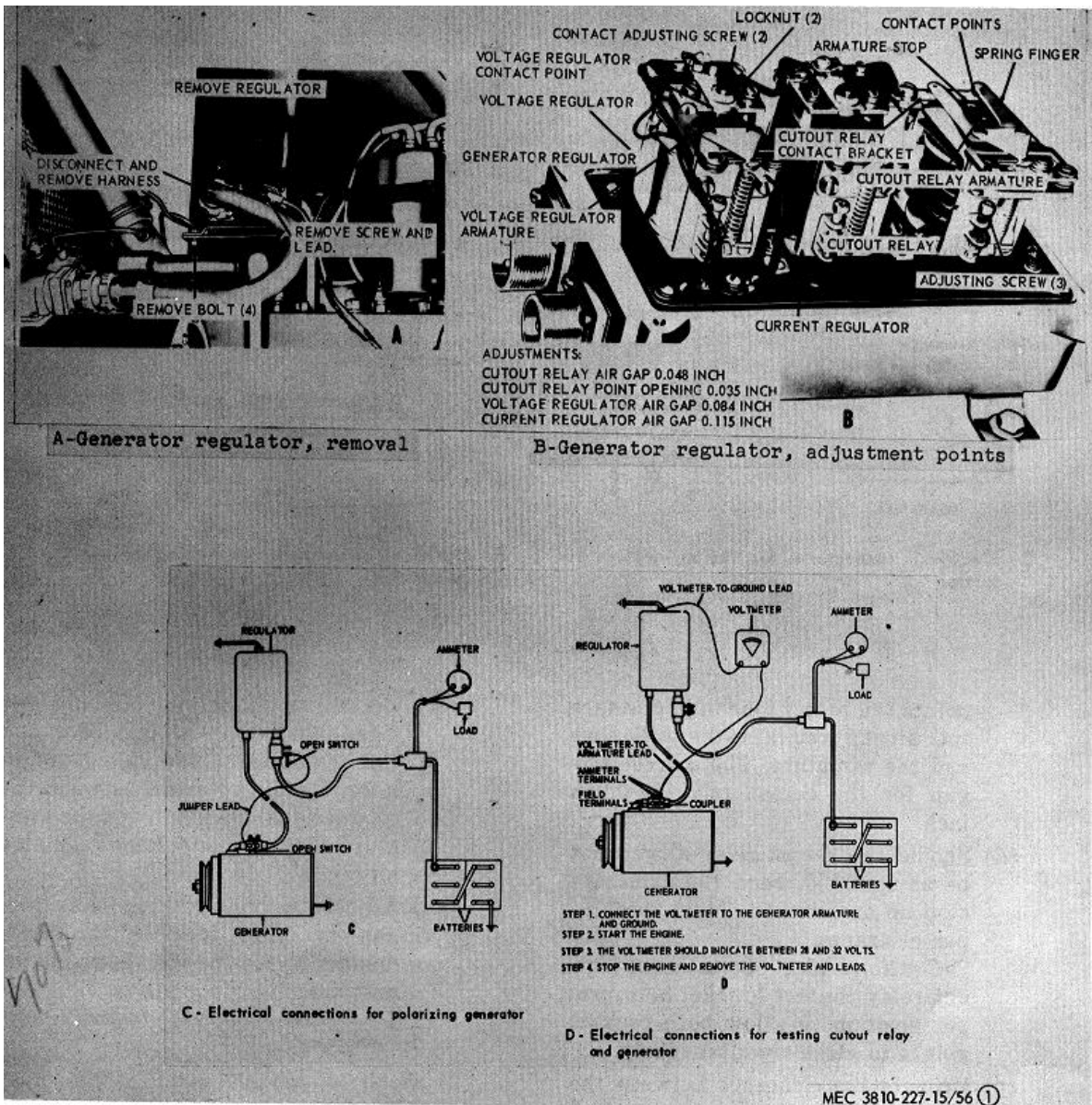

Figure 56. Generator regulator removal, adjustment, and test wiring diagram.

c. *Installation.* Install the generator regulator as instructed on figure 56.

**Note.**

The engine generator must be polarized whenever the leads to the generator or regulator have been removed or any adjustments have been made to the generator regulator. Failure to polarize the generator may cause the regulator contacts to be damaged by vibration, heavy arcing, and burning.

**Note.**

Polarize the generator by disconnecting the field lead at the

regulator and momentarily connecting a jumper lead between the generator field terminal and the regulator battery terminal. Remove the jumper lead and connect field lead to the regulator (C, fig. 56).

d. *Test and Adjustment.*

(1) Mechanical adjustments.

- (a) Disconnect regulator to battery cable.
- (b) Remove regulator cover.
- (c) Press down on the cutout relay armature (B, fig. 56) until the contact



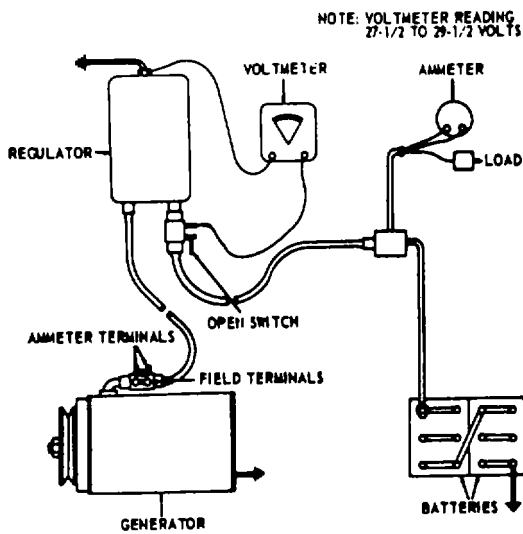

E - Electrical connections for testing voltage regulator

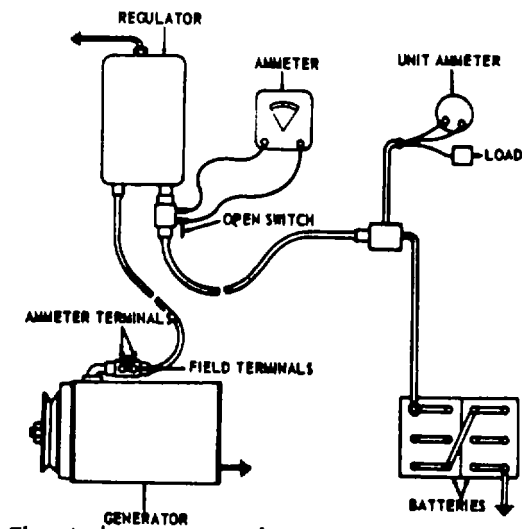

F - Electrical connections for testing current regulator

MEC 3810-27-15/56(2)

Figure 56-Continued.

points are barely touching. Measure the air-gap between the coil core and the armature. The correct air-gap for the cutout relay is 0.048 inch.

- (d) Should the cutout relay air-gap not be as specified, bend the armature stop up or down to obtain the proper clearance.

**Caution:**

**Make certain the cutout relay contact bracket is in proper position to allow both contact points to close simultaneously.**

- (e) Measure the clearance between the contact points. The proper cutout relay point opening is 0.036 inch.
- (f) If the cutout relay point opening is not as specified, loosen the two screws securing the cutout relay contact bracket to the cutout relay and raise or lower the cutout relay contact bracket until the specified air-gap is obtained. Secure the adjustment by tightening the two screws.
- (g) Push down on the voltage regulator armature until the voltage regulator contact point barely touches the

adjusting screw. Measure the air-gap between the coil core and the armature of the voltage regulator. Do not measure between the core residual brass pin and the armature. The correct voltage regulator air-gap is 0.084 inch.

- (h) Adjust the current regulator air-gap to 0.115 inch in the same manner as for the voltage regulator unit described in g above.

**Note.**

**Refer to C, figure 56 and polarize the generator.**

- (2) *Electrical adjustments.* Install set of test adapters as illustrated in figure 56.
  - (a) *Cutout relay closing voltage.* With voltmeter connected as shown in D, figure 56, start the engine and slowly increase speed until the cutout relay contact points close. Observe voltage reading at which this occurs. It should be 25 to 27 volts. If adjustment is necessary, turn the adjusting screw clockwise to increase or counterclockwise to decrease closing voltage. Set closing voltage at 26 volts.

- (b) *Voltage regulator opening voltage.* with voltmeter connected as shown on E, figure 56, increase rpm to operating speed. Observe reading on voltmeter. It should read 27.5 to 29.5 volts. If adjustment is necessary turn the voltage regulator adjusting screw clockwise to increase and counterclockwise to decrease. Set voltage at 29.2 volts.
- (c) *Current regulator maximum amperage.* With ammeter connected as shown on F, figure 56, and either the test set carbon pile load set up at 25 to 30 amps, or first having operated the starter for 10 to 15 seconds to provide the load, increase rpm to operating speed, observe reading on ammeter at which points first vibrate. This should be 38 to 42 amperes. If adjustment is necessary, adjust the current regulator to a0 amperes in the same manner as the voltage regulator.
- (d) Replace generator regulator cover and repeat all tests before removing adapters. Run regulator voltage and amperage output through several cycles of increasing and decreasing engine speed from idle to operating to idle speed to make sure adjustments are stable.
- (e) Remove adapters and connect cables.

#### **107. Instrument Panel Components**

*a. Removal and Installation.* Remove and install the instrument panel components as instructed on figure 57.

*b. Cleaning and Inspection.* Clean and inspect. Replace damaged or defective instrument panel components.

#### **108. Water Temperature Warning Light and Sending Unit**

##### *a. Removal.*

- (1) Remove the ring and lens from lamp base and remove lamp.
- (2) Remove the water temperature warning light and sending unit as instructed on figure 57.

##### *b. Cleaning and Inspection.*

- (1) Clean the water temperature warning light and sending unit with a cloth dampened with an approved cleaning solvent and dry thoroughly.
- (2) Inspect the water temperature warning light and sending unit for proper operation. Replace a defective warning light or sending unit.

##### *c. Installation.*

- (1) Install the water temperature warning light and sending unit as illustrated on figure 57.
- (2) Install the lamp, lens and ring on the base.

#### **109. Temperature Gage and Thermostat Sending Unit**

*a. Removal.* Remove the temperature gage and thermostat sending unit as instructed on figure 57.

##### *b. Cleaning and Inspection.*

- (1) Clean the temperature gage and thermostat sending unit with a cloth dampened with an approved cleaning solvent and dry thoroughly.
- (2) Inspect the temperature gage and thermostat sending unit for proper operation. Replace a defective temperature gage and defective thermostat sending unit.

*c. Installation.* Install the temperature gage and thermostat sending unit as illustrated on figure 57.

#### **110. Panel Light Assembly**

##### *a. Removal.*

- (1) Turn and remove lamp cover from base and remove lamp.
- (2) Remove the panel light assembly as instructed on figure 57.

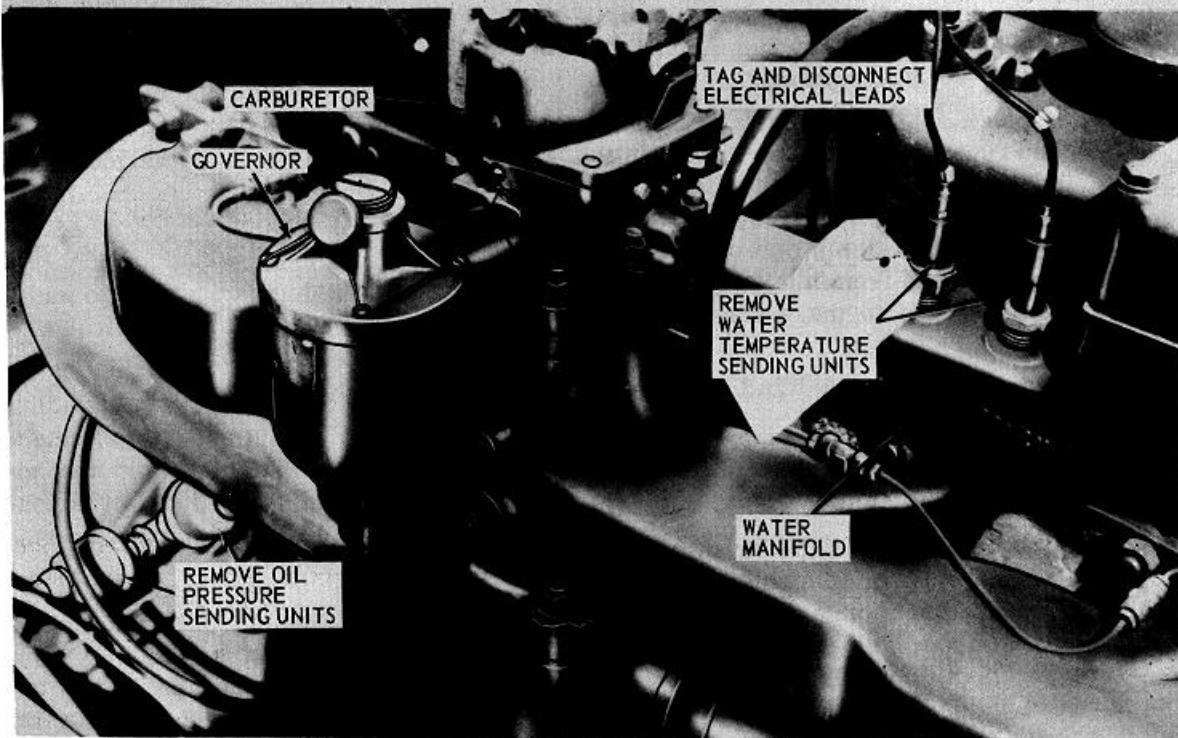
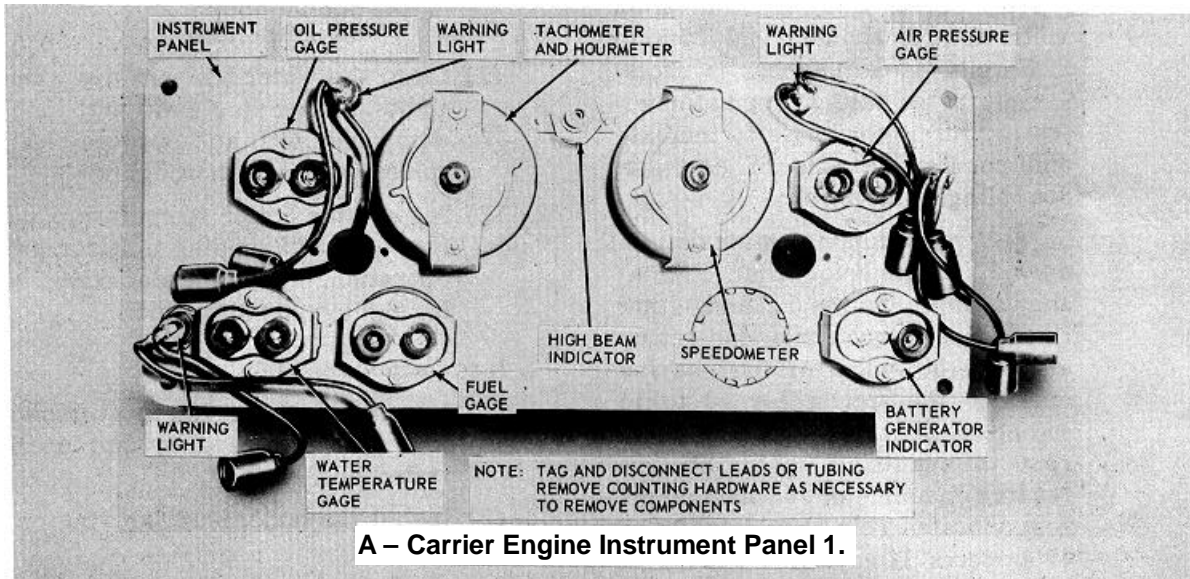

MEC 3810-227-15/57 (1)

Figure 57. Instrument panel gages, controls, lights, and temperature sending units, removal and installation.

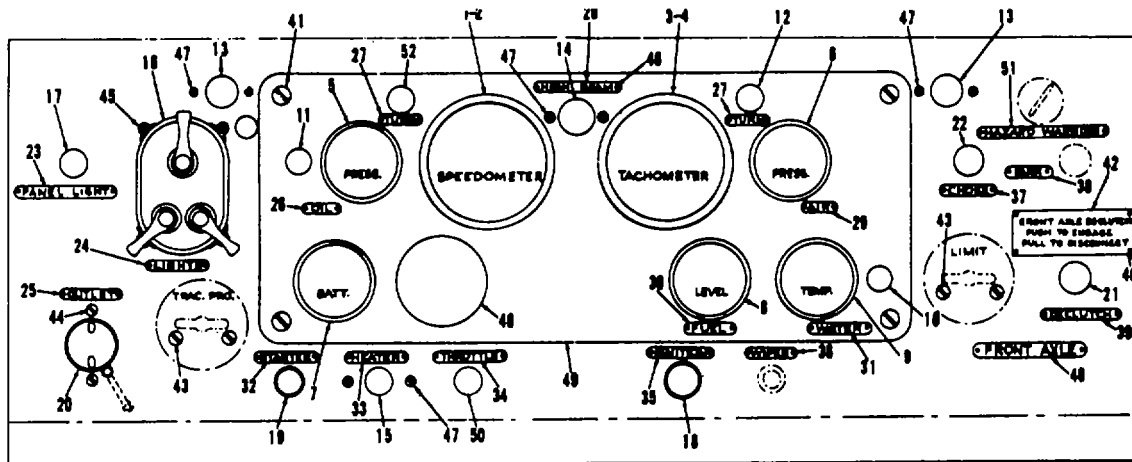

MEC 3810-227-15/57 (2)

- |                                     |                           |                                  |
|-------------------------------------|---------------------------|----------------------------------|
| 1 Speedometer                       | 19 Starter push switch    | 37 Choke data plate              |
| 2 Speedometer drive shaft           | 20 Utility outlet         | 38 Park data plate               |
| 3 Tachometer                        | 21 Control cable          | 39 Declutch data plate           |
| 4 Tachometer drive shaft            | 22 Choke control          | 40 Front axle data plate         |
| 5 Oil pressure indicator            | 23 Panel light data plate | 41 Receptacle any.               |
| 6 Air pressure indicator            | 24 Lights data plate      | 42 Information plate, front axle |
| 7 Batt-gen. voltage indicator       | 25 Outlet data plate      | 43 Screw                         |
| 8 Fuel level indicator              | 26 Oil data plate         | 44 Screw                         |
| 9 Heat indicator                    | 27 Turn data plate        | 45 Screw                         |
| 10 Indicator light (high heat)      | 28 High beam data plate   | 46 Screw, drive                  |
| 11 Indicator light (low oil press.) | 29 Air beam data plate    | 47 Screw                         |
| 12 Indicator light (turn signals)   | 30 Fuel data plate        | 48 Knockout plug                 |
| 13 Panel lights                     | 31 Water data plate       | 49 Mounting panel                |
| 14 Panel light (high beam)          | 32 Starter data plate     | 50 Throttle control              |
| 15 Heater switch                    | 33 Heater data plate      | 51 Hazard warning plate          |
| 16 Main light switch                | 34 Throttle data plate    | 52 Indicator light turn signal   |
| 17 Rheostat                         | 35 Ignition data plate    |                                  |
| 18 Ignition switch                  | 36 Wiper data plate       |                                  |

**C-Instrument panel assembly.**

**Figure 57. continued.**

**b. Cleaning and Inspection.**

- (1) Clean the panel light assembly with a cloth dampened with an approved cleaning solvent and dry thoroughly.
- (2) Inspect the panel light assembly for proper operation. Replace a defective panel light assembly.

**c. Installation.**

- (1) Install the panel light assembly as illustrated on figure 57.
- (2) Install the lamp and install cover.

- (1) Turn lens counterclockwise to remove and remove lamp.
- (2) Remove the high beam indicator light assembly as instructed on figure 57.

**b. Cleaning and Inspection.**

- (1) Clean the high beam indicator light assembly with a cloth dampened with an approved cleaning solvent and dry thoroughly.
- (2) Inspect the high beam indicator light assembly for proper operation. Replace a defective high beam indicator light assembly.

**c. Installation.**

- (1) Install the high beam indicator light assembly as illustrated on figure 57.
- (2) Install the lamp and install lens.

**111. High Boom Indicator Light Assembly**

**a. Removal.**

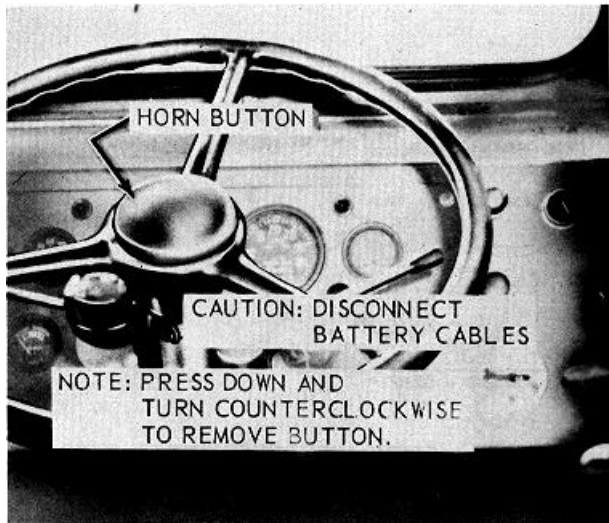

A - Horn button.

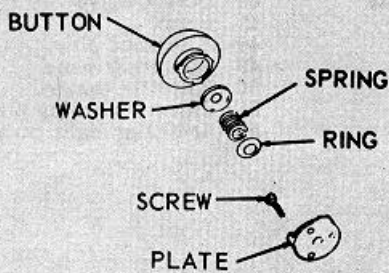

B - Horn Button, exploded view.

MEC 3810-227-15/58

Figure 58. Horn button assembly.

### 112. Horn Button Assembly

a. *Removal.* Remove the horn button assembly as instructed on figure 58.

b. *Cleaning and Inspection.*

- (1) Clean the horn button assembly with a cloth dampened with an approved cleaning solvent and dry thoroughly.
- (2) Inspect the horn button assembly for proper operation. Replace a defective horn button assembly as necessary.

c. *Installation.* Install the horn button assembly as illustrated on figure 58.

### 113. Cab and Chassis Wiring Harness Repair

a. *Inspection.* Inspect the wiring for oil-soaked, cracked, or frayed insulation, for broken wires, and for loose or corroded connections.

b. *Repair.*

- (1) *Harness repair.* Repair a broken wire by cutting a length of wire and taping it along the harness. Install two clips at either end and remove the broken wire of the harness. Secure the end of the new wire to the connection.
- (2) *Cab wiring repair.* Remove the broken wire from the connection. Splice on the length of wire needed for the repair, making sure the splice is taped sufficiently to prevent any short circuit in the wiring. Position the spliced section of wire and secure to the connection.

### 114. Rear Service Turn Light and Blackout Taillight

a. *Removal.* Remove the service turn light and blackout taillight as illustrated on figure 59.

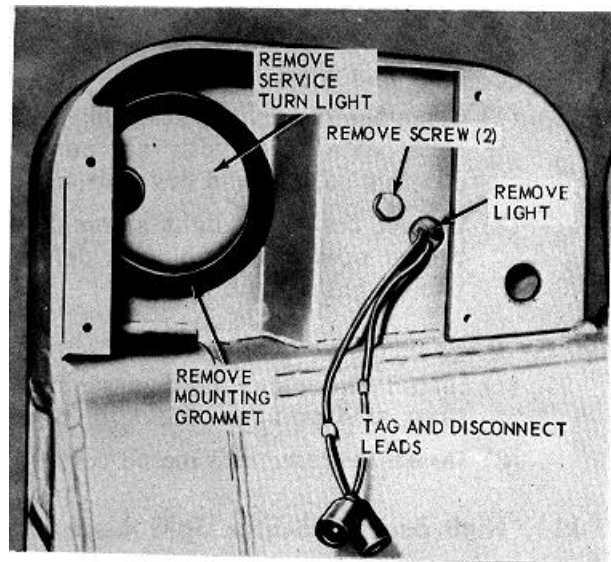

MEC 3810-227-15/59

Figure 59. Rear service turn light and blackout taillight, removal and installation

b. *Disassembly.* Disassemble the service turn light and blackout taillight as illustrated on figure 60.

c. *Cleaning and Inspection.*

- (1) Clean all parts with a cloth dampened with an approved cleaning solvent and dry thoroughly.
- (2) Inspect all parts for breaks, damage, and proper operation. Replace damaged parts as necessary.

d. *Reassembly.* Reassemble the service turn light and blackout taillight as illustrated on figure 60.

e. *Installation.* Install the service turnlight and blackout taillight as illustrated on figure 59.

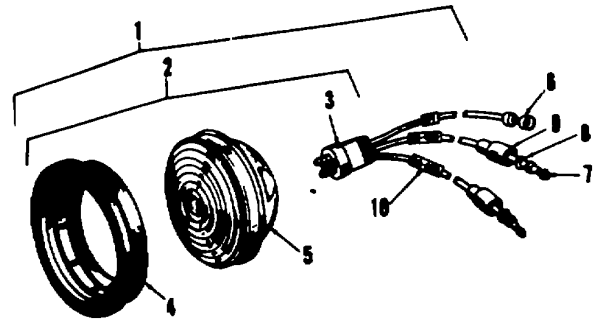

- |                            |            |
|----------------------------|------------|
| 1 Lamp and wiring assembly | 6 Terminal |
| 2 Lamp assembly            | 7 Terminal |
| 3 Electrical plug          | 8 Washer   |
| 4 Mounting grommet         | 9 Shell    |
| 5 Sealed lamp unit         | 10 Band    |

A—Service Turn Light.

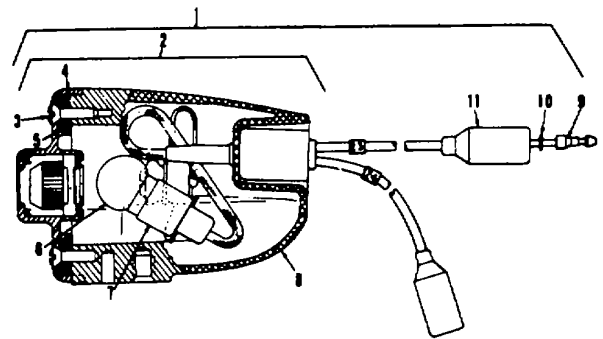

MEC 3810-227-15/60

- |                            |                     |
|----------------------------|---------------------|
| 1 Lamp and wiring assembly | 7 Socket and wiring |
| 2 Lamp assembly            | 8 Body              |
| 3 Screw                    | 9 Terminal          |
| 4 Door                     | 10 Washer           |
| 5 Gasket                   | 11 Shell            |
| 6 Bulb                     |                     |

B—Black Taillight.

**Figure 60. Service turn light and rear blackout light assemblies.**

### 115. Front Blackout Marker Service Lights

a. *Removal.* Remove the front blackout marker-service light as instructed on figure 61.

b. *Disassembly.* Disassemble the front blackout marker-service light as illustrated on figure 62.

c. *Cleaning and Inspection.*

- (1) Clean all parts with a cloth dampened with an approved cleaning solvent and dry thoroughly.
- (2) Inspect all parts for breaks, damage, and proper operation. Replace damaged parts as necessary.

d. *Reassembly.* Reassemble the blackout marker-service light as illustrated on figure 62.

e. *Installation.* Install the front blackout marker-service light as illustrated on figure 61.

### 116. Front Blackout Driving Headlight

a. *Removal.* Remove the front blackout headlight as instructed on figure 61.

b. *Disassembly.* Disassemble the front blackout headlight as illustrated on figure 62.

c. *Cleaning and Inspection.*

- (1) Clean all parts with a cloth dampened with an approved cleaning solvent and dry thoroughly.
- (2) Inspect all parts for breaks, damage, and proper operation. Replace damaged parts as necessary.

d. *Reassembly.* Reassemble the front blackout headlight as illustrated on figure 62.

e. *Installation.* Install the front blackout headlight as illustrated on figure 61.

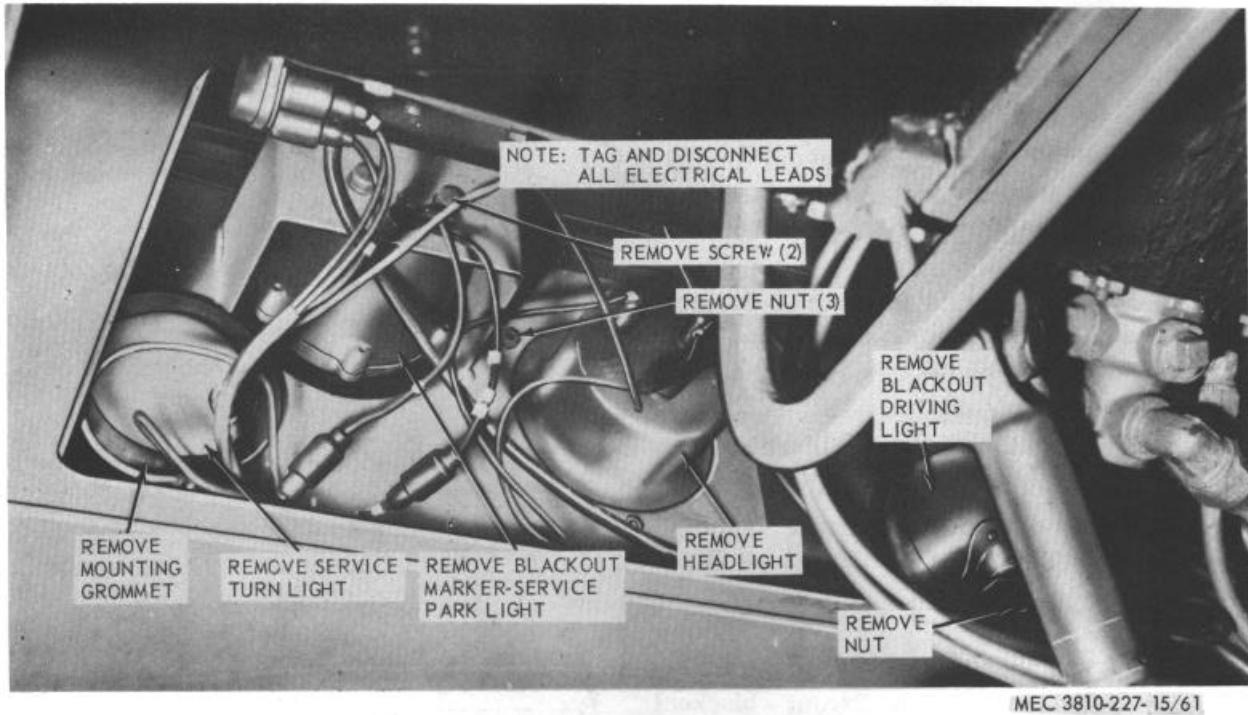

**Figure 61. Front service turnlight, blackout marker-service park, headlight and blackout driving light, removal and installation.**

### 117. Headlight

a. *Removal.* Remove the headlight as instructed on figure 61.

b. *Disassembly.* Disassemble the front headlight in the numerical sequence as illustrated on figure 62.

c. *Cleaning and Inspection.*

- (1) Clean all parts with a cloth dampened with approved cleaning solvent and dry thoroughly.
- (2) Inspect all parts for breaks, damage and proper operation. Replace damaged parts as necessary.

d. *Reassembly.* Reassemble the headlight in the reverse numerical sequence as illustrated on figure 62.

e. *Installation.* Install the headlight as illustrated on figure 61.

f. *Adjustment.*

- (1) Headlights must be adjusted properly to prevent a blinding glare to the operator of an oncoming vehicle.
- (2) Position the unloaded equipment on a flat and level surface at right angles to, and

25 feet from, a suitable vertical surface. Measure the distance from the surface the equipment is upon to the center of the headlight; mark a horizontal line the same distance on the vertical surface; mark horizontal lines on the vertical surface as illustrated on figure 63.

- (3) Remove the headlight door.
- (4) Turn the top screw in or out for vertical, adjustment and turn the side screw for horizontal adjustment of sealed beam. Use a suitable cover and cover one headlight while aiming the other.
- (5) Replace the headlight door.

### 118. Dome Light

a. *Removal.* Remove the dome light as instructed on figure 64.

b. *Cleaning and Inspection.*

- (1) Clean all parts with a cloth dampened

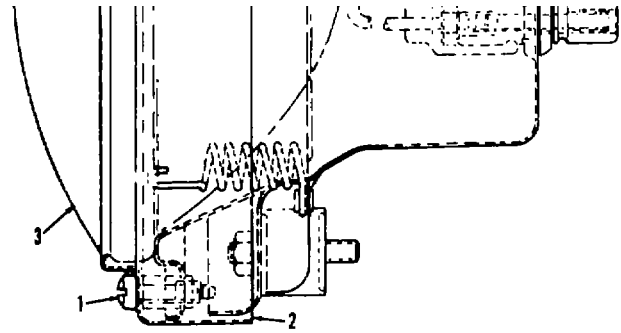
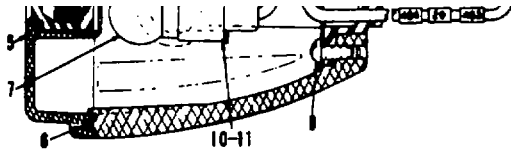

MEC 3810-227-15/62 ①

- 1 Lamp and wiring assembly
- 2 Lamp assembly
- 3 Screw
- 4 Ring
- 5 Door
- 6 Gasket
- 7 Bulb
- 8 Bulb
- 9 Screw
- 10 Screw
- 11 Screw
- 12 Socket and wiring assembly
- 13 Terminal
- 14 Washer
- 15 Shell

A—Combination blackout marker and service parking and signal lamp.

- 1 Screw
- 2 Door
- 3 Sealed unit and wiring
- 4 Grommet
- 5 Male receptacle
- 6 Female receptacle
- 7 Body

B—Headlight assembly.

- 1 Lamp and wiring assembly
- 2 Lamp assembly
- 3 Screw
- 4 Ring
- 5 Door
- 6 Gasket
- 7 Bulb
- 8 Bulb
- 9 Screw
- 10 Screw
- 11 Screw
- 12 Socket and wiring assembly
- 13 Terminal
- 14 Washer
- 15 Shell

A—Combination blackout marker and service parking and signal lamp.

- 1 Screw
- 2 Door
- 3 Sealed unit and wiring
- 4 Grommet
- 5 Male receptacle
- 6 Female receptacle
- 7 Body

B—Headlight assembly.

**Figure 62. Front light assemblies.**

with an approved cleaning solvent and dry thoroughly.

(2) Inspect all parts for breaks and other damage.

(3) Replace damaged parts as necessary.

c. *Installation.* Install the dome light as illustrated on figure 64.

**119. Horn**

a. *Removal.* Remove the horn as instructed on figure 65.

b. *Cleaning and Inspection.*

(1) Clean the horn with a cloth dampened with an approved cleaning solvent and dry thoroughly.



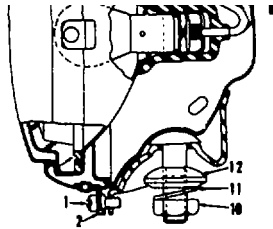

MEC 38 10-227-15/62 ②

- |                          |               |
|--------------------------|---------------|
| 1 Screw                  | 7 Connector   |
| 2 Ring                   | 8 Washer      |
| 3 Door assembly          | 9 Shell       |
| 4 Sealed unit and wiring | 10 Nut        |
| 5 Spring                 | 11 Lockwasher |
| 6 Grommet                | 12 Washer     |

C—Blackout driving lamp.

Figure 62-Continued.

- (2) Inspect the horn for proper operation. Replace a defective horn.
- c. *Installation.* Install the horn as illustrated on figure 65.

**120. Slave Receptacle**

- a. *Removal.* Remove the slave receptacle as instructed on figure 66.
- b. *Cleaning and Inspection.*
  - (1) Clean the slave receptacle with an approved cleaning solvent and dry thoroughly.
  - (2) Inspect for breaks, bends, and proper operation. Replace a damaged or defective slave receptacle.
- c. *Installation.* Install a slave receptacle as illustrated on figure 66.

**121. Stoplight Switch**

- a. *Removal.* Remove the stoplight switch as instructed on figure 67.

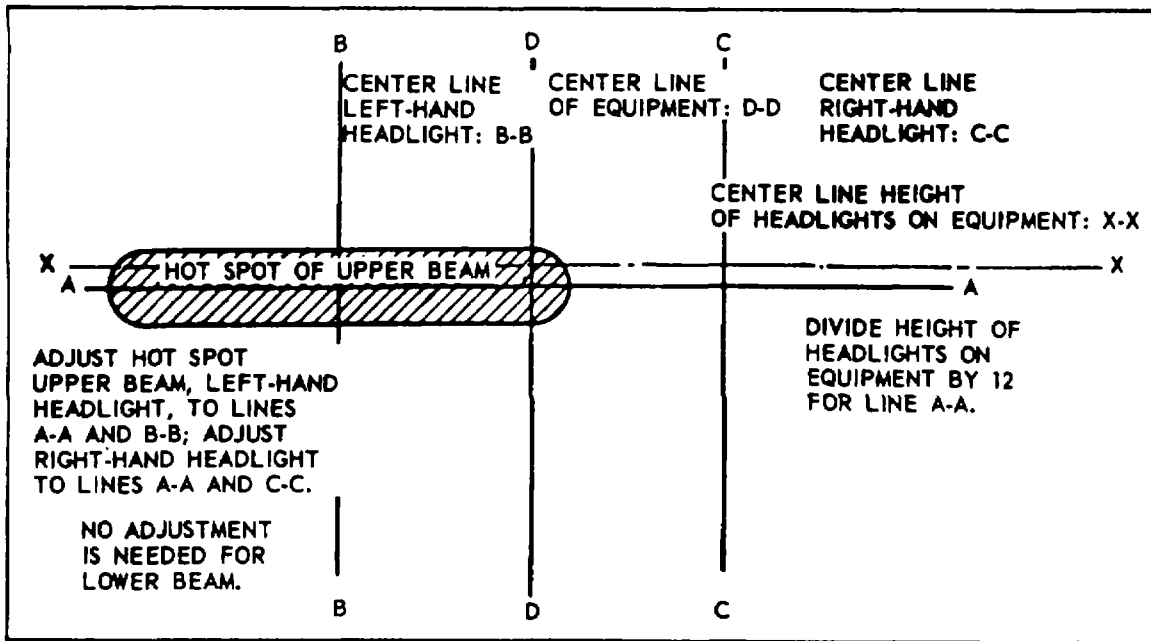

MEC 38 10-227-15/63

Figure 63. Headlight, adjusting diagram.

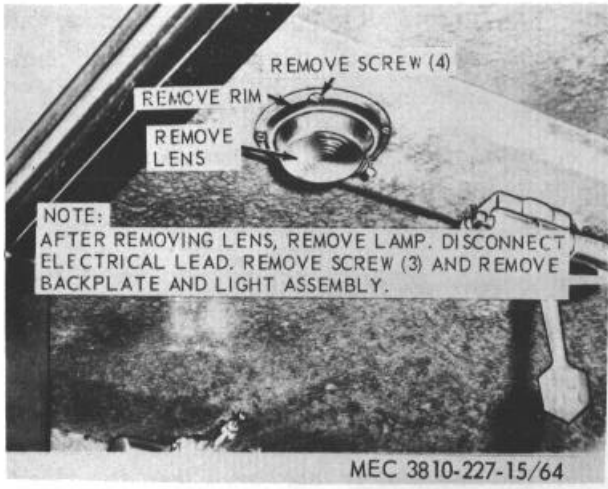

Figure 64. Dome light, removal and installation.

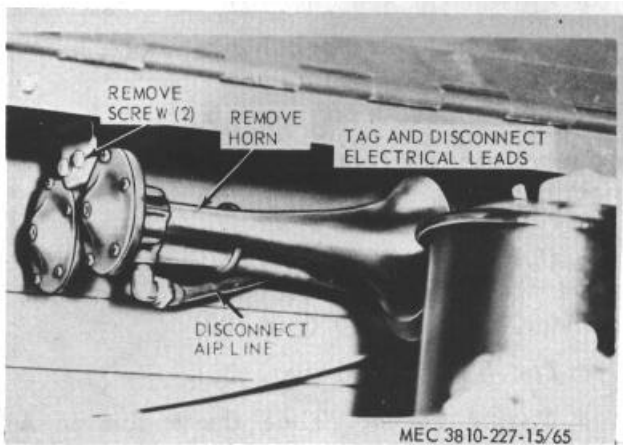

Figure 65. Horn, removal and installation.

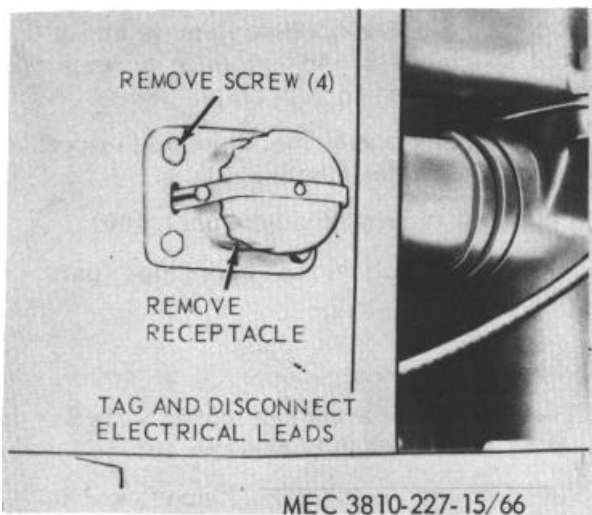

Figure 66. Slave receptacle, removal and installation.

*b. Cleaning and Inspection.*

- (1) Clean the stoplight switch with an approved cleaning solvent and dry thoroughly.
- (2) Inspect the stoplight switch for proper operation. Replace a defective stoplight switch.

*c. Installation.* Install the stoplight switch as illustrated on figure 67.

**122. Turn Signal Switch**

*a. Removal.* Remove the turn signal switch as instructed on figure 68.



Figure 67. Stoplight switch, removal and installation.

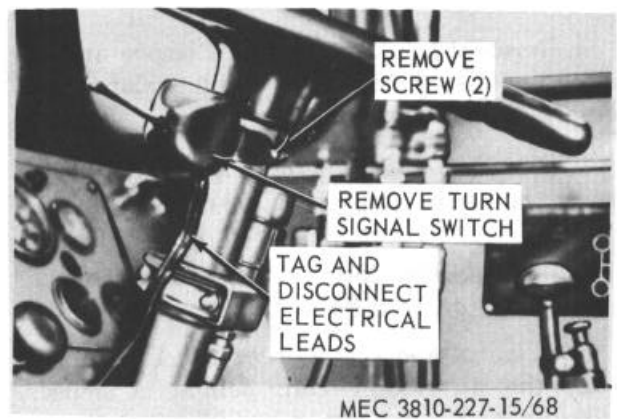
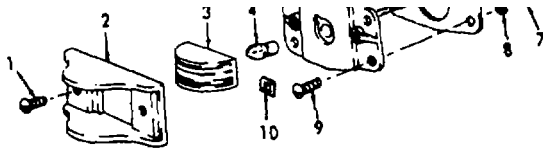

Figure 68. Turn signal switch, removal and installation.



ME C 3810-227-15/69

1 Screw	6 Gasket
2 Door	7 Nut
3 Lens	8 Washer
4 Lamp	9 Screw
5 Housing	6 Gasket
	7 Nut
	8 Washer
	9 Screw
	10 Nut

**Figure 69. Clearance light, removal, disassembly, and installation.**

*b. Cleaning and Inspection.*

- (1) Clean all parts with a cloth dampened with an approved cleaning solvent and dry thoroughly.

- (2) Inspect all parts for wear, breaks, and other damage. Replace worn and damaged parts as necessary.

*c. Installation.* Install the turn signal switch as illustrated on figure 68.

### 123. Clearance Marker Lights

*a. Removal and Disassembly.* Remove and disassemble the clearance lights as shown in figure 69.

*b. Cleaning and Inspection.* Clean the clearance lights with an approved cleaning solvent.

*c. Reassembly and Installation.* Reassemble and install the clearance lights in reverse order as shown on figure 69.

## Section VIII. CRANE ENGINE ELECTRICAL SYSTEM, CONTROLS AND INSTRUMENTS

### 124. General

The crane shovel 24-volt electrical system consists of two 12-volt batteries connected in series, a starter, generator, generator regulator, ignition coil, distributor, spark plugs, lights, gages, and the necessary wiring to operate all components of the electrical system. For proper removal and installation of all wiring on the crane, refer to the wiring diagram (fig. 3).

### 125. Distributor

*a. Removal and Installation.* Remove and install the distributor in a similar manner as described in paragraph 98.

*b. Cleaning and Inspection.* Clean and inspect the distributor (para. 98).

### 126. Distributor Coil, Points, Condenser, Resistor, and Rotor Cap

*a. Removal and Installation.* Remove and install the distributor coil, points, condenser, resistor, and rotor cap in a similar manner as described in paragraph 99.

*b. Cleaning and Inspection.* Clean and inspect the distributor coil, points, condenser, resistor, and rotor cap (para. 99).

*c. Test.* Test the coil (para. 99).

*d. Engine Timing.* Time the engine in a similar manner as described in paragraph 99.

### 127. Spark Plugs and Cables

*a. Removal and Installation.* Remove and install the spark plugs and cables in a similar manner as described in paragraph 100.

*b. Cleaning and Inspection.* Clean and inspect spark plug and cables (para. 100).

*c. Test.* Test the spark plugs (para. 100).

*d. Adjustment.* Adjust the spark plugs (para. 100).

### 128. Starter Solenoid

*a. Test.* Test the starter solenoid in a similar manner as instructed in paragraph 101.

*b. Removal and Installation.* Remove and install the starter solenoid in a similar manner as described in paragraph 101.

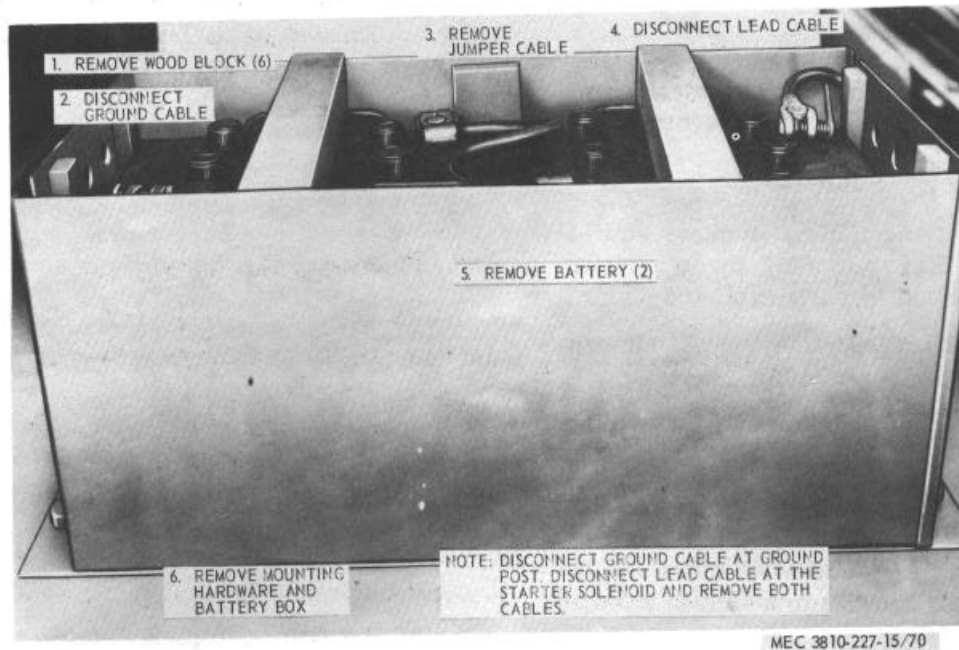

**Figure 70. Crane batteries, cables, and box, removal and installation.**

*c. Cleaning and Inspection.* Clean and inspect the starter solenoid (para. 101).

### 129. Starter Assembly

*a. Removal and Installation.* Remove and install the starter assembly in a similar manner as described in paragraph 102.

*b. Cleaning and Inspection.* Clean and inspect the starter (para. 102).

*c. Brush Replacement.* Replace starter brushes in a similar manner as described in paragraph 102.

### 130. Batteries, Cables and Battery Box

*a. Test.* Test the batteries as described in paragraph 103.

*b. Removal and Installation.* Remove and install the batteries, cables and battery box as shown in figure 70.

*c. Cleaning, Inspection and Repair.*

- (1) Clean all parts and inspect for defects.
- (2) Replace defective parts.

### 131. Generator Drive Belt

*a. Adjustment.* Adjust the crane engine generator belt as shown in figure 71.

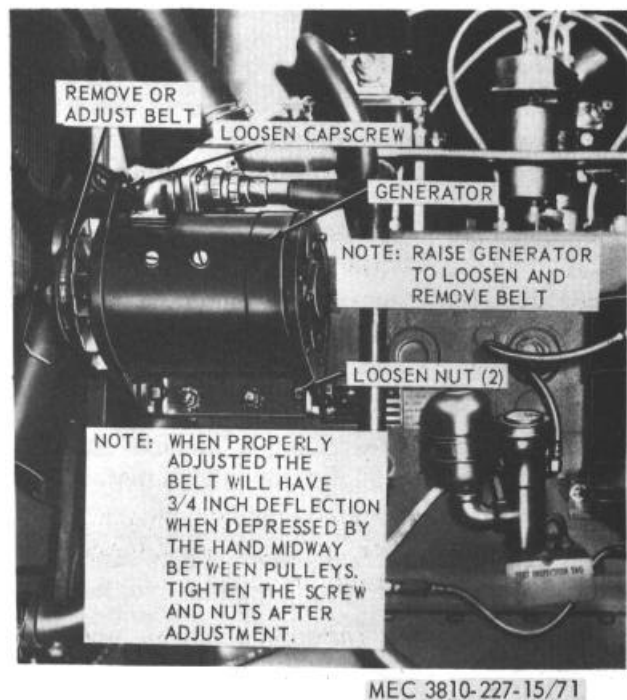

**Figure 71. Crane engine generator belt, adjustment, removal and installation.**

*b. Removal and Installation.* Remove and install the drive belt as shown in figure 71.

*c. Cleaning and Inspection.*

- (1) Clean the drive belt with a cloth dampened

with an approved cleaning solvent.

- (2) Inspect the drive belt for cracks, breaks, and frayed or stretched condition. Replace a defective drive belt.

### 132. Generator Assembly

- a. *Removal and Installation.* Remove and install the generator assembly in a similar manner as described in paragraph 105.
- b. *Cleaning and Inspection.* Clean and inspect the generator (para. 106).
- c. *Test.* Test the generator in a similar manner as described in paragraph 105.

### 133. Generator Brushes

- a. *Removal and Installation.* Remove and install the generator brushes in a similar manner as described in paragraph 105.
- b. *Cleaning and Inspection.* Clean and inspect brushes (para. 105).

### 134. Generator Regulator

- a. *Removal and Installation.* Remove and install the generator regulator in a similar manner as described in paragraph 106.
- b. *Cleaning and Inspection.* Clean and inspect the generator regulator (para. 106).
- c. *Test.* Test the generator in a similar manner as described in paragraph 106.

### 135. Instrument Panel Components

- a. *Removal and Installation.* Remove and install instrument panel components as instructed in figure 72.
- b. *Cleaning and Inspection.* Clean and inspect. Replace damaged or defective instrument panel components.

### 136. Oil Pressure Sending Unit, Safety Switch, and Pressure Switch

- a. *Removal and Installation.* Remove oil pressure sending unit, safety switch, and pressure switch as shown in figure 73.
- b. *Cleaning and Inspection.* Clean and inspect. Replace defective sending unit or switch.

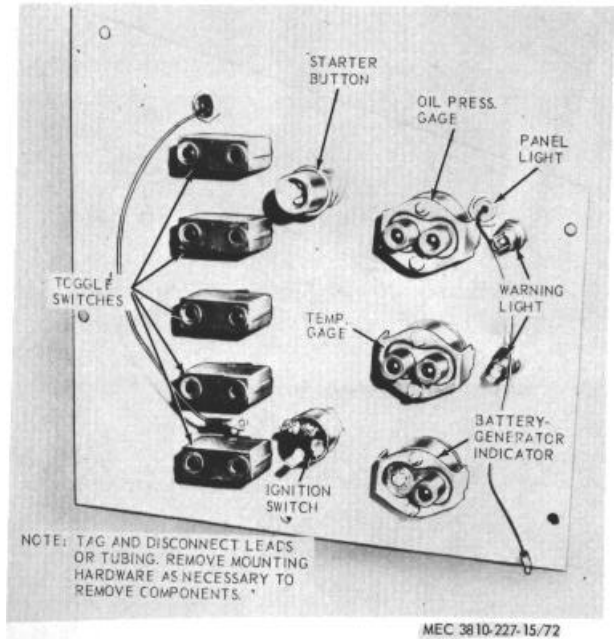

Figure 72. Instrument panel and components, removal and installation.

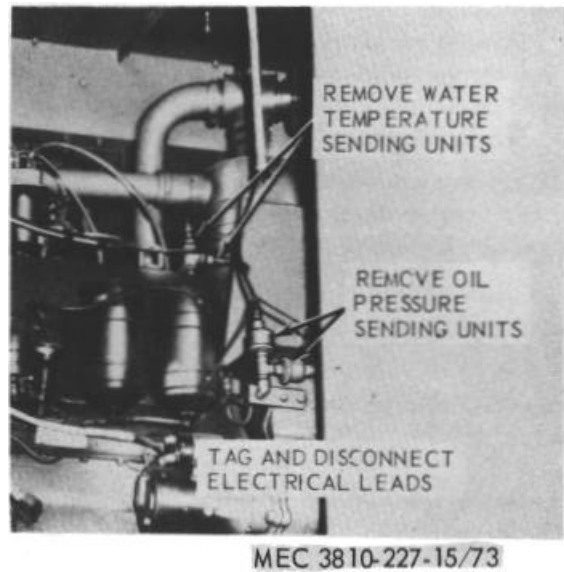
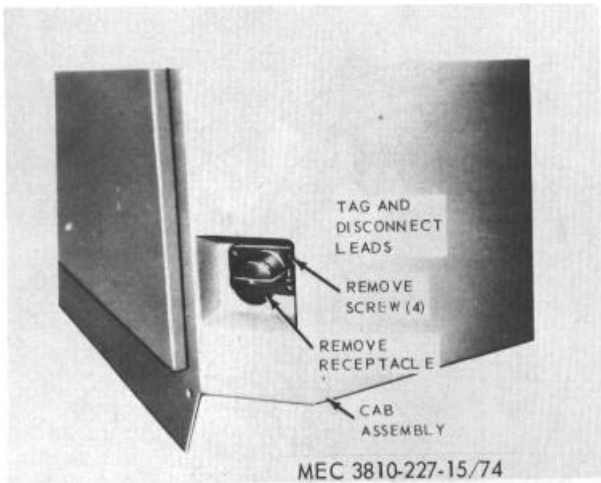

Figure 73. Oil pressure sending unit, safety switch, and oil pressure switch, water temperature sending unit, removal and installation.

### 137. Water Temperature Sending Units

- a. *Removal and Installation.* Remove and install the water temperature sending units as shown in figure 73.
- b. *Cleaning and Inspection.* Clean and inspect. Replace defective sending units.



**Figure 74. Slave receptacle, removal and installation.**

### 138. Slave Receptacle

*a. Removal and Installation.* Remove and install the slave receptacle as shown in figure 74.

*b. Cleaning and Inspection.*

- (1) Clean the slave receptacle with a cloth dampened with an approved cleaning solvent.
- (2) Inspect the slave receptacle for breaks, frayed or broken leads, and other damage. Replace a defective or damaged unit.

### 139. Pistol Grip Trouble Light and Reel

*a. Removal and Installation.* Remove and install pistol grip trouble light and reel as shown in figure 76.

*b. Cleaning, Inspection and Repair.* Clean and inspect. Repair or replace damaged or defective parts as necessary.

### 140. Horn Assembly

*a. Removal and Installation.* Remove and install the horn as shown in figure 76.

*b. Cleaning and Inspection.*

- (1) Clean the horn with a cloth dampened with an approved cleaning solvent and dry.
- (2) Inspect the horn for proper operation. Replace a defective horn.

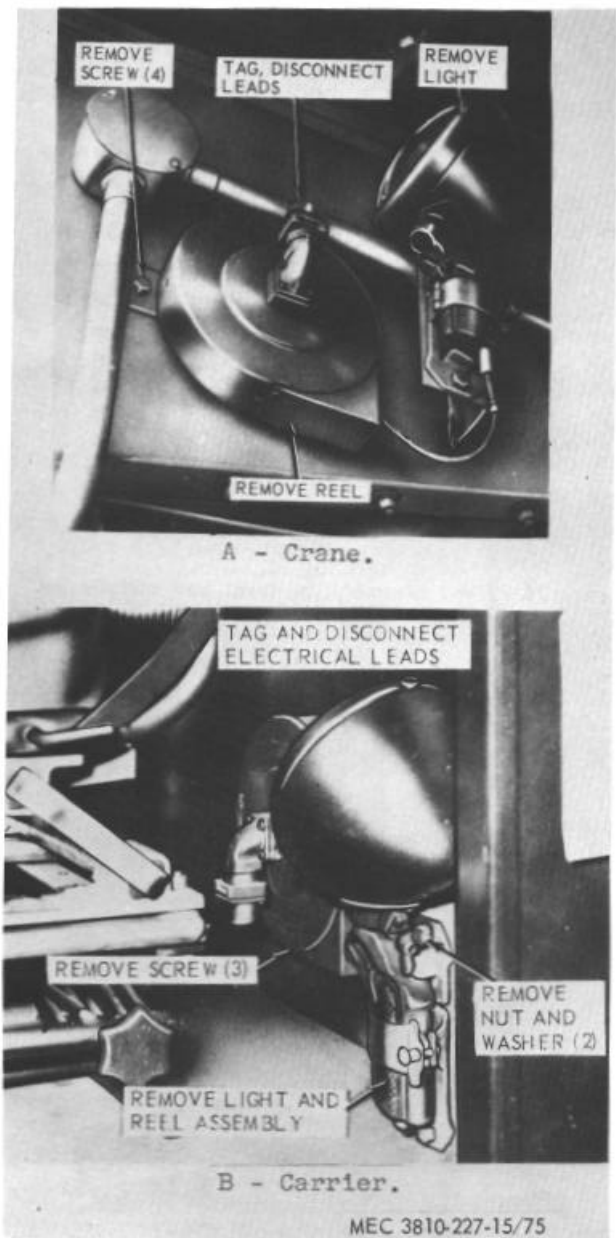

**Figure 75. Pistol grip trouble light and reel, removal and installation.**

### 141. Floodlights

*a. Removal and Installation.* Remove and install the floodlight as instructed in figure 77.

*b. Disassembly.* Disassemble the floodlight in the numerical sequence shown in figure 78.

*c. Cleaning, Inspection, and Repair.* Clean and inspect all parts. Replace or repair defective parts.

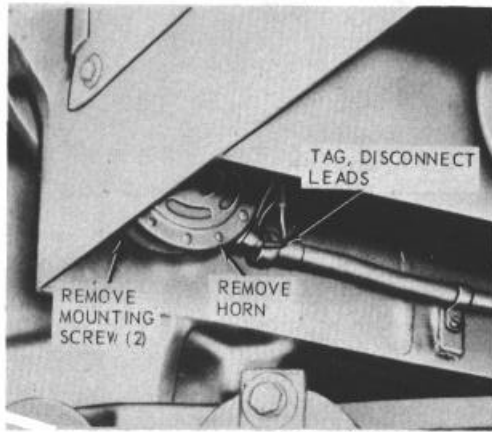

Figure 76. Horn assembly, removal and installation.

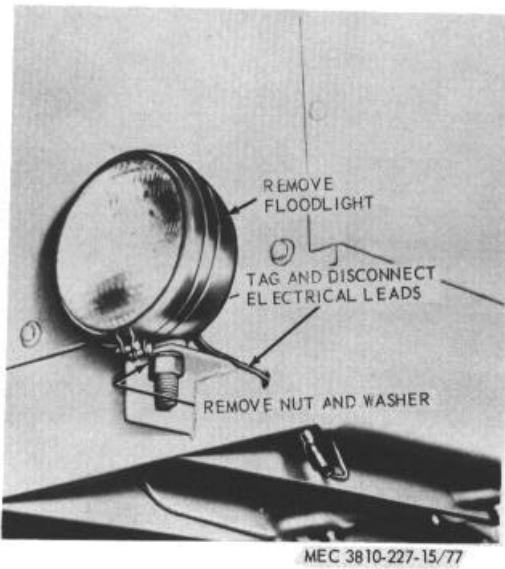
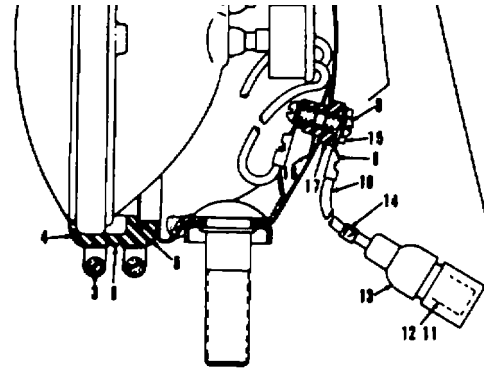

Figure 77. Floodlight, removal and installation.

d. *Reassembly.* Reassemble the floodlight in the reverse of the numerical sequence as illustrated in figure 78.



MEC 3810-227-15/78

- |                         |                         |
|-------------------------|-------------------------|
| 1 Floodlight and wiring | a10 Wire                |
| 2 Floodlight assembly   | 11 Terminal             |
| 3 Screw                 | 12 Sleeve               |
| 4 Molding               | 13 Shell                |
| 5 Molding               | 14 Band                 |
| 6 Mounting ring         | 15 Lockwasher           |
| 7 Sealed unit           | 16 Spring               |
| 8 Screw                 | 17 Terminal plate       |
| 9 Terminal              | 18 Connector and wiring |
|                         | 19 Body                 |

Figure 78. Floodlight assembly.

#### 142. Clearance Light

a. *Removal and Installation.* Remove and install clearance lights in a similar manner as described in paragraph 123.

b. *Cleaning and Inspection.* Clean and inspect the clearance lights (para. 123).

#### 143. Cab Wiring Harness

Inspect and repair the cab wiring harness in a similar manner as for the carrier cab and chassis wiring harness (para. 113).

### Section IX. CARRIER ENGINE COOLING SYSTEM

#### 144. General

The carrier engine has a pressure cooling system. Water from the radiator is forced by the water pump through the engine water jackets and back into the

radiator for cooling. Until the engine reaches operating temperature, all or part of the water leaving the engine jackets is bypassed by means of thermostats, directly to the water pump for recirculation.

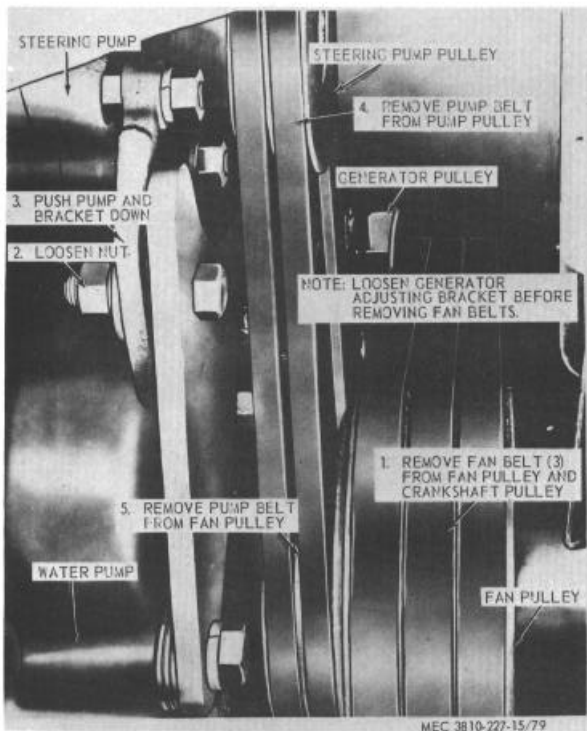

**Figure 79. Fan belts and hydraulic steering pump belt, removal and installation.**

Draincocks are located on the bottom of the water pump and at the lower-right, rear side of the engine block.

#### 145. Fan Belt and Hydraulic Steering Pump Belt

##### a. Removal.

- (1) Remove the three fan belts from the generator and crankshaft pulley in numerical sequence as instructed on figure 79.
- (2) Remove the hydraulic steering pump belt in numerical sequence as instructed on figure 79.

##### b. Cleaning and Inspection.

- (1) Clean belts with a cloth dampened with an approved cleaning solvent.
- (2) Inspect belts for fraying, breaks, cracks, and other damage. Replace belts as necessary.

##### c. Installation.

- (1) Install the hydraulic steering pump belt in the reverse of the numerical sequence as illustrated on figure 79.

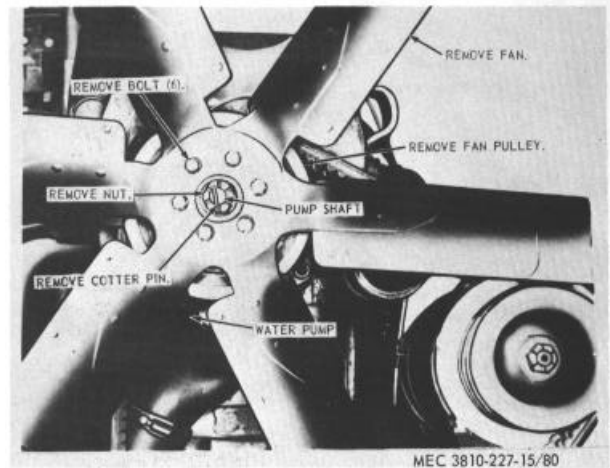

**Figure 80. Carrier engine fan, removal and installation.**

- (2) Install the three fan belts on the generator and crankshaft pulley in the reverse of the numerical sequence as illustrated on figure 79.
- (3) Adjust the hydraulic steering pump and fan belts (fig. 53).

#### 146. Fan

a. *Removal.* Remove the carrier engine fan as instructed on figure 80.

##### b. Cleaning and Inspection.

- (1) Clean all parts with an approved cleaning solvent.
- (2) Inspect all parts for cracks, breaks, and other damage. Replace defective fan.

c. *Installation.* Install the carrier engine fan as illustrated on figure 80.

#### 147. Radiator Shroud

##### a. Removal.

- (1) Drain the cooling system.
- (2) Remove the carrier engine fan (para. 146).
- (3) Remove the carrier engine radiator shroud as instructed on figure 81.

##### b. Cleaning and Inspection.

- (1) Clean all parts with an approved cleaning solvent.



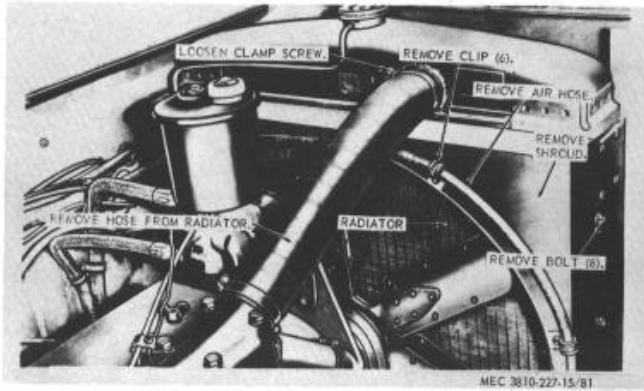

**Figure 81. Carrier engine radiator shroud, removal and installation.**

- (2) Inspect all parts for bends, breaks, and other damage. Replace defective parts as necessary.

*c. Installation.*

- (1) Install the carrier engine radiator shroud as illustrated on figure 81.
- (2) Install the carrier engine fan (para. 146).
- (3) Fill the cooling system to proper level.

**148. Water Tubes, Hoses, and Fittings**

*a. Removal.*

- (1) Drain the cooling system.
- (2) Remove the carrier engine water tubes, hoses, and fittings as instructed on figure 82.

*b. Cleaning and Inspection.*

- (1) Clean all parts with an approved cleaning solvent.
- (2) Inspect the tubes, hoses, and fittings for leaks, cracks, breaks, and other damage. Replace defective parts as necessary.

*c. Installation.*

- (1) Install the carrier engine water tubes, hoses, and fittings as illustrated on figure 82.
- (2) Fill the cooling system to proper level.

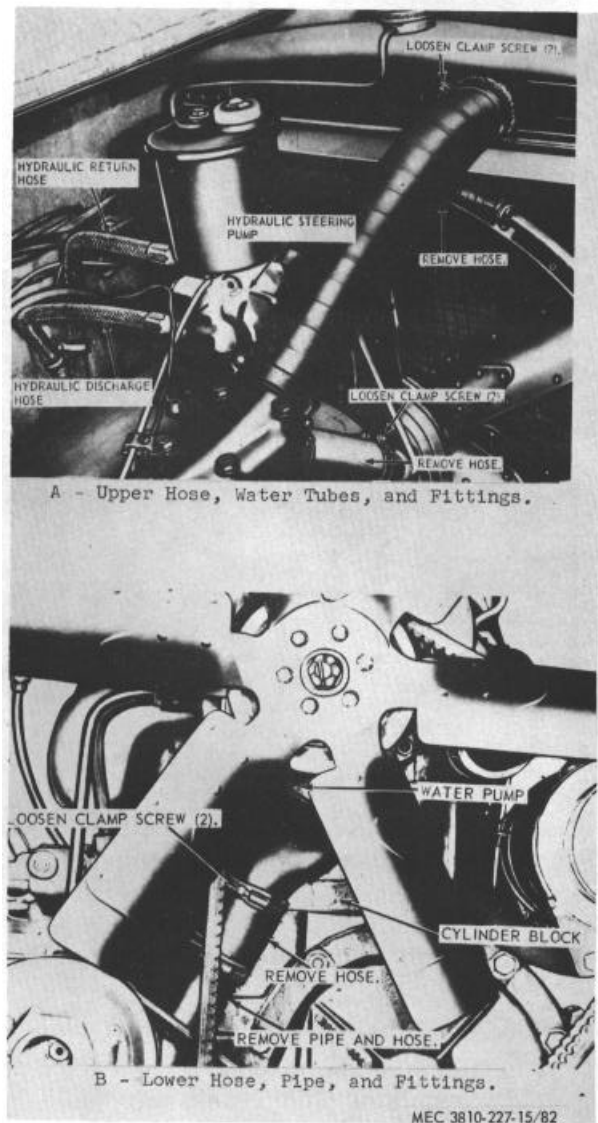
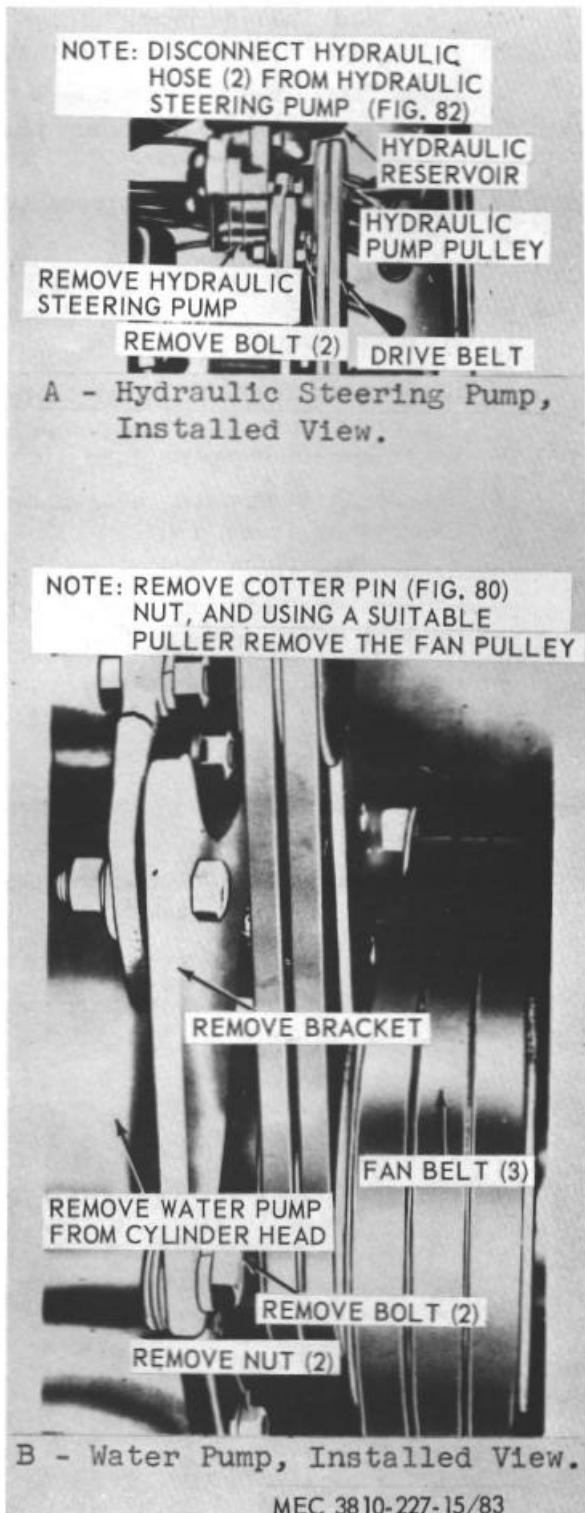

**Figure 82. Carrier engine water tubes, hoses, and fittings, removal and installation.**

**149. Water Pump, Fan Pulley, and Hydraulic Steering Pump**

*a. Removal.*

- (1) Drain the cooling system.
- (2) Remove the three fan belts and the hydraulic steering pump belt (para. 145).
- (3) Remove the carrier engine water tubes and hoses from the water pump (para. 148).
- (4) Remove the fan from the pulley (para. 146).



**Figure 83. Carrier engine water pump, fan pulley, and hydraulic steering pump, removal and installation.**

- (5) Remove the carrier engine water pump, fan pulley, and hydraulic steering pump as instructed on figure 83.

*b. Cleaning and Inspection.*

- (1) Clean all parts with an approved cleaning solvent.
- (2) Inspect the water pump, fan pulley, and hydraulic steering pump for breaks, leaks, cracks, and other damage. Replace defective pumps and pulley as necessary.

*c. Installation.*

- (1) Install the carrier engine water pump, fan pulley and hydraulic steering pump as illustrated on figure 83.
- (2) Install the fan to the fan pulley (para. 146).
- (3) Install the carrier engine water tubes and hoses to the water pump (para. 148).
- (4) Install the three fan belts and the hydraulic steering pump belt (para. 145).
- (5) Adjust the hydraulic steering pump belt and the three fan belts (fig. 53).
- (6) Fill the cooling system to proper level.

**150. Thermostat Cover and Thermostats**

*a. Removal.*

- (1) Drain the cooling system.
- (2) Remove the hoses from the thermostat cover, radiator, and water pump (para. 148).
- (3) Remove the carrier engine thermostat cover and the two thermostats as instructed on figure 84.

*b. Tests.*

- (1) Suspend the thermostats and a thermometer in a pan of water and heat the water until the thermostats starts to open. They should start to open at 160° F. and should be fully open at 180° F.
- (2) Allow water to cool with the thermostats in it. Test the temperature of the water at the time the thermostats start to close and again when they

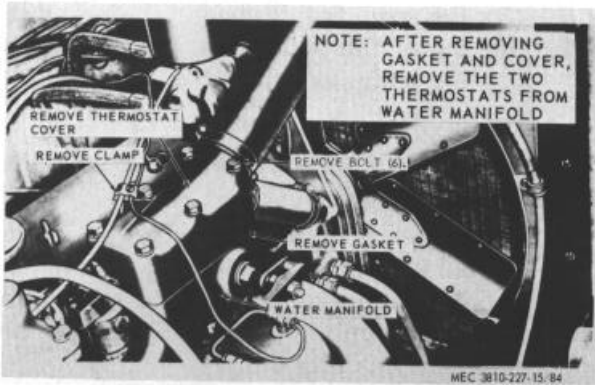

**Figure 84. Carrier engine thermostat cover and thermostats, removal and installation.**

are fully closed. The thermostats should start to close at 175° F. and be fully closed at 155° F.

*c. Cleaning and Inspection.*

- (1) Clean all parts with an approved cleaning solvent.
- (2) Inspect the thermostats for proper operation and other damage. Replace defective thermostats.
- (3) Inspect all other parts for cracks, breaks, and other damage. Replace all defective parts.

*d. Installation.*

- (1) Install the two carrier engine thermostats and the thermostat cover as illustrated on figure 84.
- (2) Install the hoses on the thermostat cover, radiator, and water pump (para. 148).
- (3) Fill the cooling system to proper level.

**151. Water Manifolds**

*a. Removal.*

- (1) Drain the cooling system.
- (2) Remove the hoses from the thermostat cover, radiator, water pump, and water manifolds (para. 148).
- (3) Remove the thermostat cover and two thermostats (para. 150).
- (4) Remove the thermostat sending unit and temperature warning light sending unit (paras. 108 and 109).
- (5) Remove the carrier engine water manifolds as instructed on figure 85.

*b. Cleaning and Inspection.*

- (1) Clean all parts with a approved cleaning solvent.
- (2) Inspect all parts for breaks, cracks, defective parts and gaskets.

*c. Installation.*

- (1) Install the carrier engine water manifolds as illustrated on figure 85.

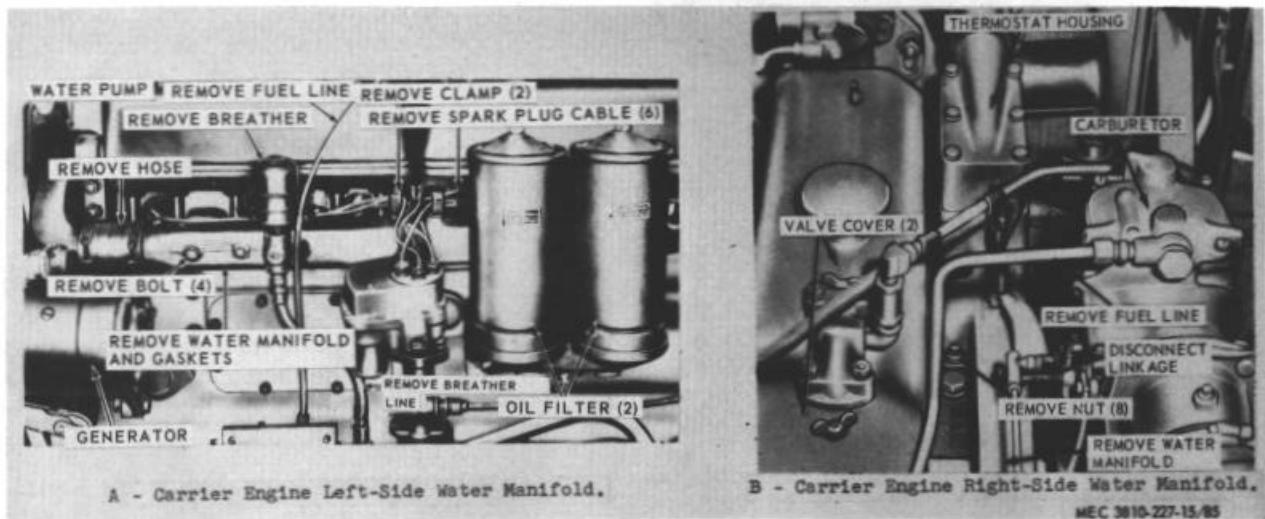

**Figure 85. Carrier engine water manifolds, removal and installation.**

- (2) Install the two thermostats and the thermostat cover (para. 150).
- (3) Install the hoses on the thermostat cover, water pump, radiator, and water manifolds (para. 148).

- (4) Install the thermostat sending unit and temperature warning light sending unit (paras. 108 and 109).
- (5) Fill the cooling system to proper level.

## Section X. CRANE ENGINE COOLING SYSTEM

### 152. General

The engine temperature is controlled by the circulation of coolant through the coolant pump, which forces the coolant through the engine water jackets and back into the radiator for cooling. Until the engine is up to operating temperature, all or part of the coolant leaving the engine is bypassed, by means of a thermostat, directly to the pump for recirculation. Draincocks are located on the bottom of the radiator and on the forward, left side of the engine block.

### 153. Hose, Lines, and Fittings

#### a. Removal.

- (1) Drain the cooling system.
- (2) Remove the hose, lines, and fittings as instructed on figure 86.

#### b. Cleaning and Inspection.

- (1) Clean all parts with an approved cleaning solvent.
- (2) Inspect hose and fittings for cracks, breaks, and other damage. Replace all defective parts.

#### c. Installation.

- (1) Install the hose, lines, and fittings as illustrated on figure 86.
- (2) Fill radiator with coolant.

### 154. Thermostat Housing Assembly

#### a. Removed.

- (1) Remove the radiator-to-thermostat housing hose and pipe assembly (para. 158).
- (2) Remove the thermostat housing as instructed on figure 87.

#### b. Cleaning and Inspection.

- (1) Clean all parts thoroughly.

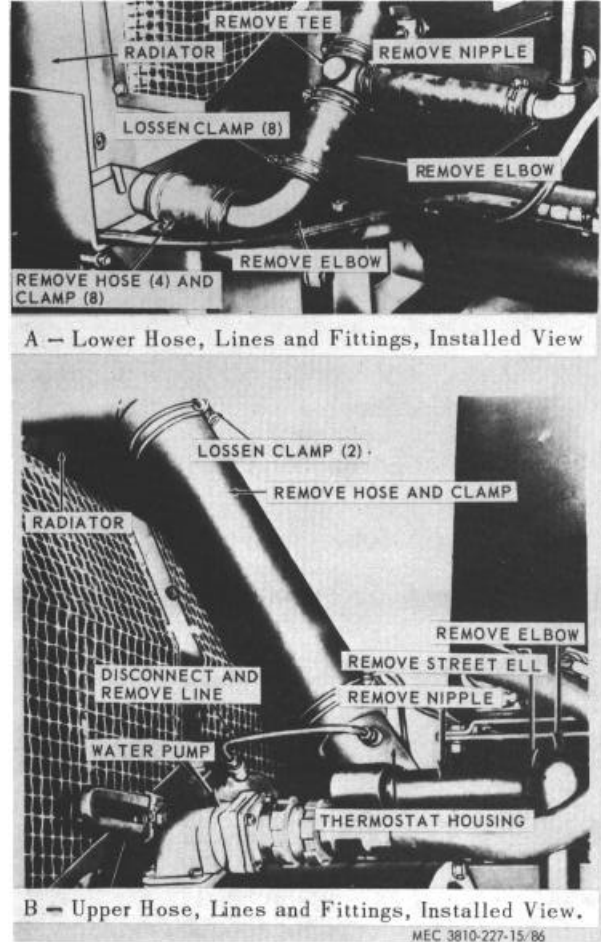

**Figure 86. Hose, lines, and fittings, removal and installation.**

- (2) Inspect the thermostat housing for breaks, cracks, and other damage. Replace defective thermostat housing.

#### c. Installation.

- (1) Install the thermostat housing as illustrated on figure 87.
- (2) Install the pipe assembly and radiator-to-thermostat housing hose (para. 153).

## 155. Thermostat Assembly

### a. Removal.

- (1) Remove the thermostat housing (para. 154).
- (2) Remove the thermostat assembly as instructed on figure 88.

### b. Cleaning and Inspection.

- (1) Clean the thermostat in an approved cleaning solvent.
- (2) Inspect the thermostat and gasket for proper function and other damage. Replace defective thermostat.

**c. Test.** Test the thermostat for opening and closing range of 165 to 180°F. in the same manner as described in paragraph 150.

### d. Installation.

- (1) Install the thermostat as illustrated on figure 88.
- (2) Install the thermostat housing (para. 154).

## 156. Radiator Shroud and Fan Guard

**a. Removal.** Remove radiator shroud and fan guard as instructed on figure 89.

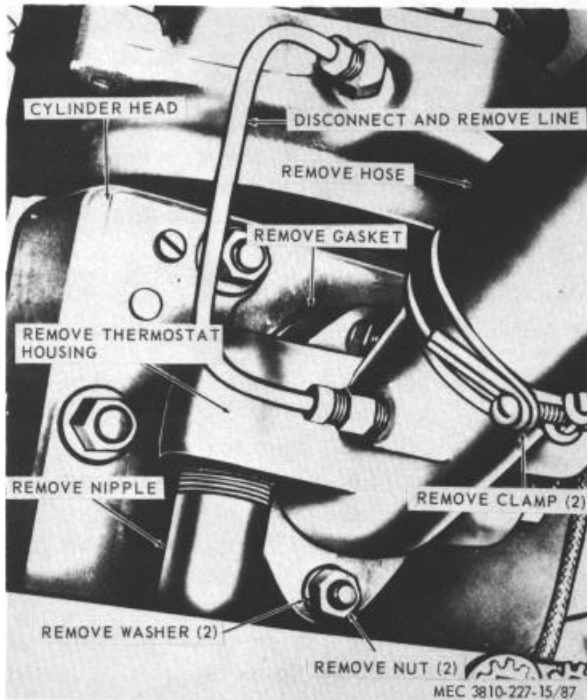

Figure 87. Thermostat housing assembly, removal and installation.

### b. Cleaning and Inspection.

- (1) Clean the radiator shroud and fan guard with an approved cleaning solvent.
- (2) Inspect the shroud for breaks, bends, and other damage. Replace defective shroud.

**c. Installation.** Install the radiator shroud and fan guard as illustrated on figure 89.

## 157. Fan and Fan Belt

### a. Removal.

- (1) Remove the radiator shroud and fan guard (para. 156).
- (2) Remove the fan and fan belt as instructed on figure 90.

### b. Cleaning and Inspection.

- (1) Clean the fan and fan belt with an approved cleaning solvent.
- (2) Inspect the fan for breaks, bends, and other damage. Replace defective fan.
- (3) Inspect the fan belt for breaks, fraying, cracks, and other damage. Replace defective fan belt.

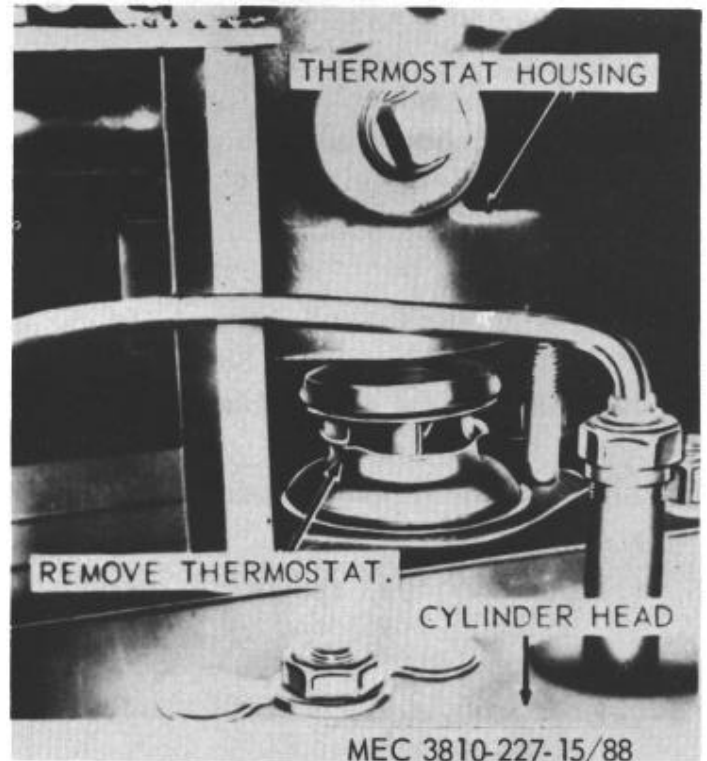
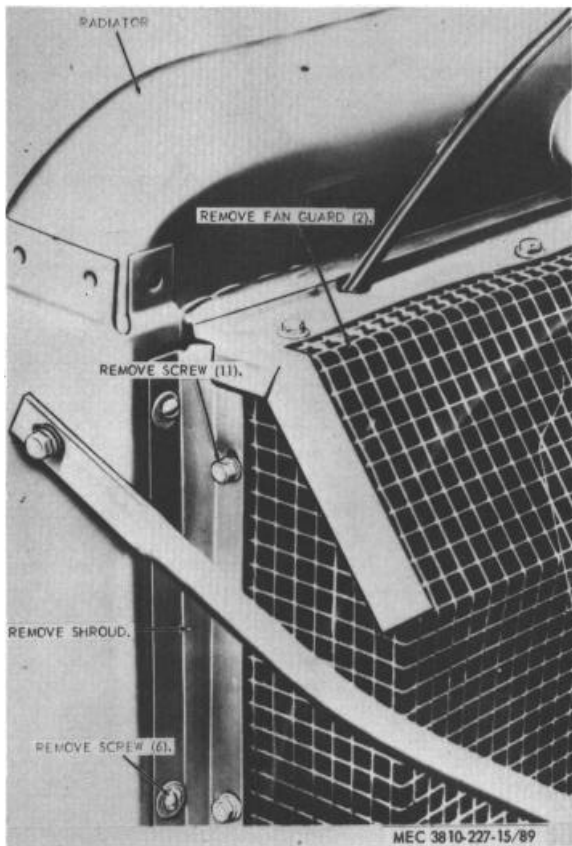

Figure 88. Thermostat, removal and installation.



**Figure 89. Radiator shroud and fan guard, removal and installation.**

*c. Installation.*

- (1) Install the fan belt and fan as illustrated on figure 90.
- (2) Install the radiator shroud and fan guard (para. 156).

**158. Water Pump Assembly**

*a. Removal.*

- (1) Drain the cooling system.
- (2) Remove the fan guard (para. 156).
- (3) Remove the generator belt (para. 131).

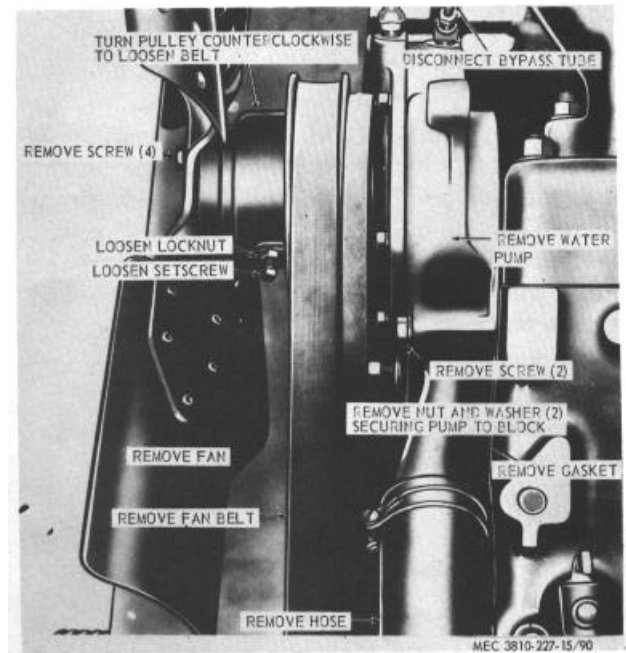

**Figure 90. Fan, fan belt, and water pump, removal and installation.**

- (4) Remove the fan and fan belt (para. 157).
- (5) Remove the water pump as instructed on figure 90.

*b. Cleaning and Inspection.*

- (1) Clean the water pump assembly with an approved cleaning solvent.
- (2) Inspect the water pump assembly for breaks, proper operation, and other damage. Replace defective water pump.

*c. Installation.*

- (1) Install the water pump as illustrated on figure 90.
- (2) Install the fan and fan belt (para. 157).
- (3) Install the generator belt (para. 131).
- (4) Install the fan guard (para. 156).
- (5) Fill the cooling system.

**Section XI. CARRIER ENGINE LUBRICATION SYSTEM**

**159. General**

Engine lubrication is furnished by a gear-type recirculating oil pump which is driven from the camshaft.

The pump is located in the crankcase and forces oil through the oil filter to the main gallery line and is distributed to the main bearings and other lower parts of the engine. Oil to the rocker arms is fed up through

the front cam journal, through a passage in the front of the block leading through the head gasket, into the front cylinder head, to the front rocker arm shaft, through the front rocker arm shaft, then down to a passage in the block, and up to the rear cylinder head. From the rear cylinder head the oil travels through the rear rocker arm shaft, down through the block, through the filter into the cooler, and back to the crankcase.

**160. Crankcase Breather**

a. *Removal.* Remove the breather as instructed on figure 91.

b. *Cleaning, Inspection, and Repair.*

- (1) Clean all parts with an approved cleaning solvent and dry thoroughly.

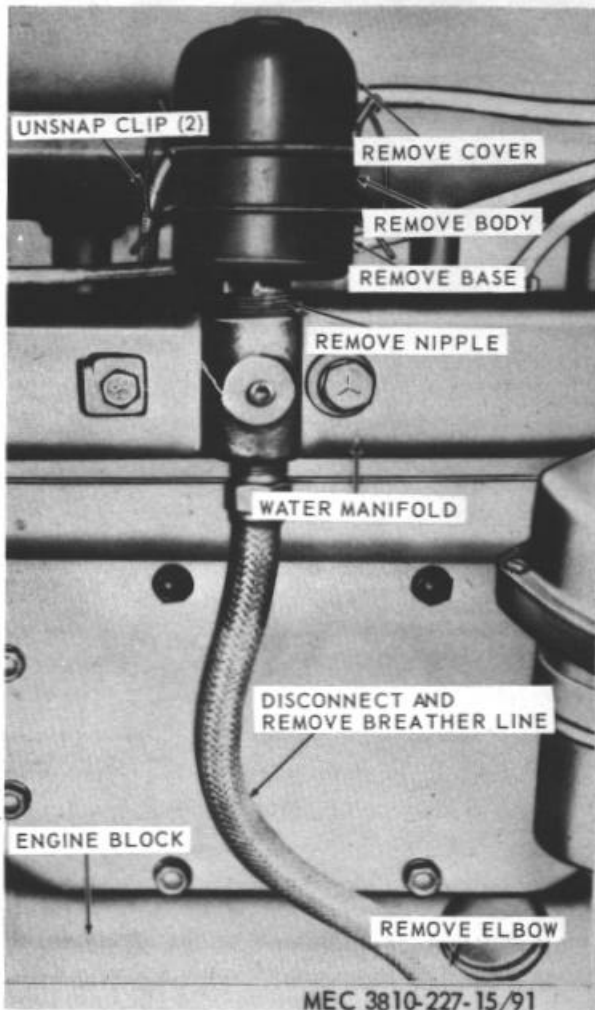

**Figure 91. Carrier engine crankcase breather, removal and installation.**

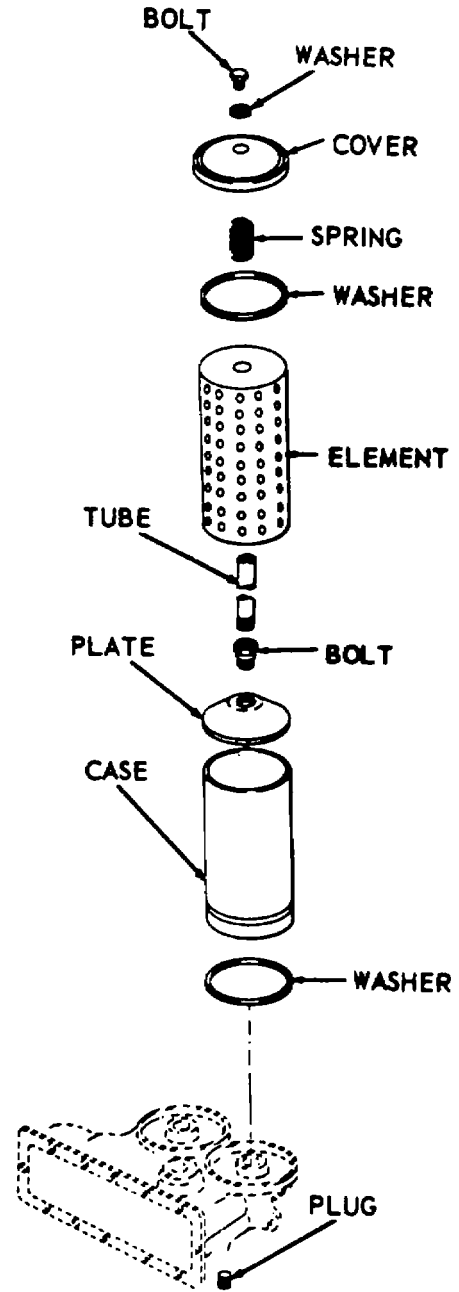

**Figure 92. Carrier engine oil filter, exploded view.**

- (2) Inspect all parts for breaks, leaks, dents, and other damage. Repair or replace all damaged parts as necessary.

c. *Installation.* Install the breather as illustrated on figure 91.

### 161. Oil Filter

a. *Removal.*

- (1) Remove engine access panel.
- (2) Remove the drain plug and allow the oil to drain from the filter.
- (3) Remove the filter as illustrated on figure 92.

b. *Cleaning, Inspection, and Repair.*

- (1) Clean all parts with an approved cleaning solvent and dry thoroughly.
- (2) Inspect all parts for dents, fractures, and other damages.
- (3) Repair or replace all damaged parts as necessary. Note. If the filter cover is removed, for any reason, the gasket must be replaced.

c. *Installation.*

- (1) Install the oil filter as illustrated on figure 92.
- (2) Install the drain plug in the filter base.
- (3) Fill crankcase to proper operating level (LO 53810-227-15).
- (4) Start the engine and check the filters for leaks.
- (5) Install the engine access panel.

### 162. Oil Pressure Relief Valve

a. *Removal and Installation.* Remove and install

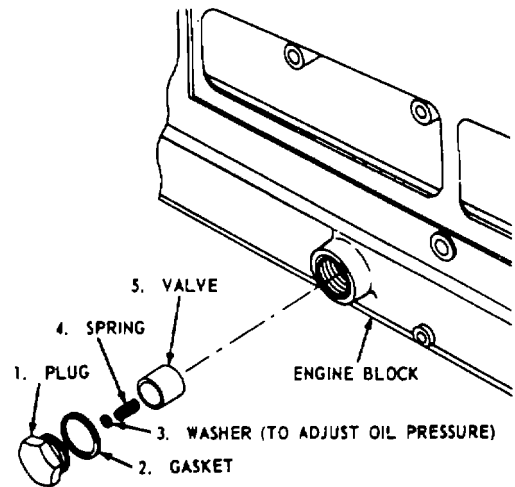

MEC 3810-227-15/93

**Figure 93. Oil pressure relief valve, exploded view.**

the oil pressure relief valve as illustrated in figure 93.

b. *Cleaning and Inspection.*

- (1) Clean all parts with an approved cleaning solvent.
- (2) Inspect all parts for excessive wear, breaks, and other damage.

c. *Adjustment.* Adjust the pressure relief valve by installing the correct number of washers to obtain the correct spring tension to regulate the operating oil pressure to 40-50 pounds. Add washers to increase pressure; remove washers to decrease pressure.

## Section XIII. CRANE ENGINE LUBRICATION SYSTEM

### 163. General

The internal parts of the engine are pressure-lubricated. The oil is forced by a pump from the crankcase to the two oil filters, through the oil cooler, and back to the crankcase. The oil filters are equipped with replaceable elements.

### 164. Oil Filters

a. *Removal.* Remove the oil filter as instructed on figure 94.

b. *Cleaning, Inspection, and Repair.*

- (1) Clean all parts with an approved cleaning solvent.
- (2) Inspect all lines and fittings for damage. Replace defective lines and fittings.
- (3) Inspect the oil filter bodies and mountings for dents, breaks, and other damage. Repair or replace all defective parts.
- (4) Replace filter elements and gaskets.

c. *Installation.*

- (1) Install the oil filter as illustrated on figure 94.



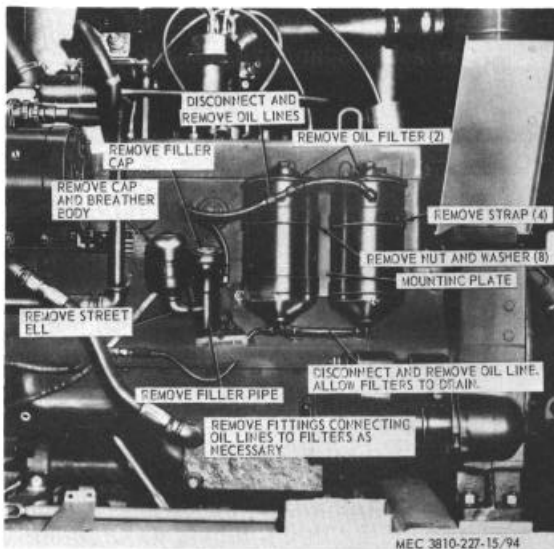

**Figure 94. Crane engine, oil filters, crankcase filler, and breather, removal and installation.**

- (2) Fill crankcase to proper operating level (LO 5-3810-227-15).

- (3) Start engine and check filters for leaks.

### 165. Crankcase Filler and Breather

*a. Removal.* Remove the crankcase filler and breather as instructed on figure 94.

*b. Cleaning and Inspection.*

- (1) Clean all parts with an approved cleaning solvent.
- (2) Inspect all parts for breaks, cracks, and other damage. Replace all defective parts.

*c. Installation.* Install the crankcase filler and breather as illustrated on figure 94.

### 166. Oil Pressure Relief Valve

The oil pressure relief valve, located on the right side of the engine block, is the same as the relief valve on the carrier engine and is removed, repaired, adjusted and installed in the same manner (para. 162).

## Section XIII. CARRIER ENGINE INTAKE AND EXHAUST SYSTEM

### 167. General

The intake and exhaust system consists of the intake and exhaust manifolds, muffler, and pipe. The exhaust manifold expels burned exhaust gas from the cylinders, through the exhaust pipe and muffler, to the atmosphere. The intake manifold delivers the air and fuel mixture to each cylinder. The six intake and six exhaust valves are located in the cylinder heads and are actuated by the camshaft through the tappets, push rods, and rocker arms. Adjusting screws in the rocker arms provide the means of adjusting the valve clearance. The stem of each valve slides within a guide pressed into the cylinder heads. The intake valves control the admission of the fuel-air mixture to the cylinders, while the exhaust valves permit the expulsion of gases from the cylinders.

### 168. Muffler

*a. Removal.* Remove the carrier muffler as instructed on figure 95.

*b. Cleaning and Inspection.*

- (1) Clean all parts in an approved cleaning solvent with a wire brush.
- (2) Inspect muffler for cracks, holes, leaks, and other damage.
- (3) Inspect the tailpipe for bends, cracks, rust, and other damage.
- (4) Inspect all clamps and mounting hardware. Replace all defective muffler parts as necessary.

*c. Installation.* Install the muffler as illustrated on figure 95.

### 169. Intake and Exhaust Manifold

*a. Removal.*

- (1) Remove the muffler (para. 168).
- (2) Remove the carburetor from the intake manifold (para. 86).
- (3) Remove the fuel lines and fittings (para. 85).

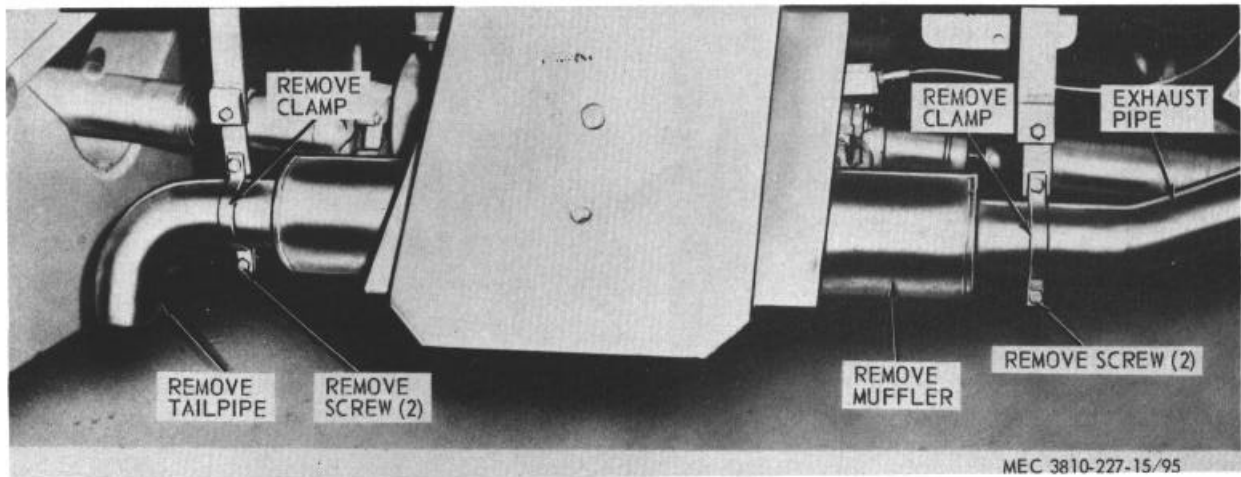

**Figure 95. Carrier muffler, removal and installation.**

- (4) Remove the intake and exhaust manifold in numerical sequence as instructed on figure 96.

**b. Cleaning and Inspection.**

- (1) Clean all parts with an approved cleaning solvent.
- (2) Inspect the intake manifold and exhaust manifold sections and center sections for cracks, breaks, or warps. Replace as necessary.
- (3) Inspect all capscrews, nuts, and studs for stripped or burred threads. Replace as necessary.

**c. Installation.**

- (1) Install the intake and exhaust manifold in the reverse of the numerical sequence as illustrated on figure 96.
- (2) Install the fuel lines and fittings (para. 85).
- (3) Install the carburetor on the intake manifold (para. 86).
- (4) Install the muffler (para. 168).

**170. Valve Cover**

**a. Removal.**

- (1) Remove the breather tube from the valve cover assembly (para. 160).
- (2) Remove the accelerator bellcrank (para. 89).

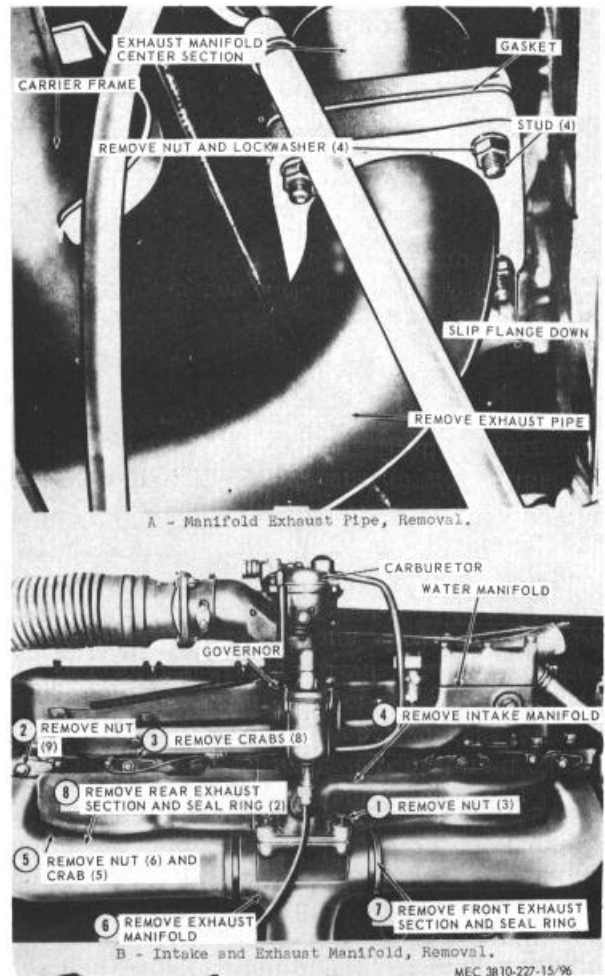

**Figure 96. Intake and exhaust manifold removal and installation.**

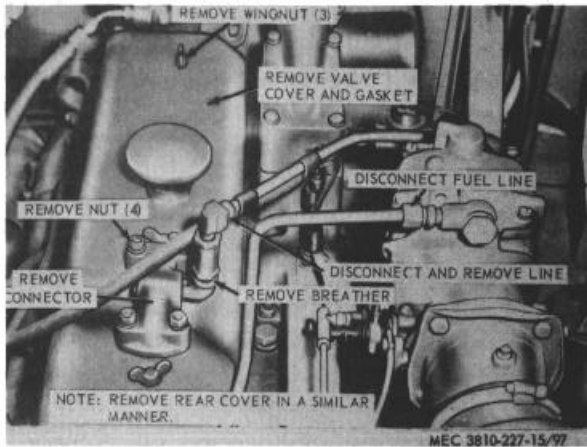

**Figure 97. Valve cover, removal and installation.**

- (3) Remove the rocker arm valve covers as instructed on figure 97.

*b. Cleaning and Inspection.*

- (1) Clean all parts with an approved cleaning solvent.
- (2) Inspect the valve cover for dents, elongated holes, and other damage.
- (3) Replace damaged parts as necessary.

*c. Installation.*

- (1) Install the rocker arm valve covers as illustrated on figure 97.
- (2) Install the accelerator bellcrank (para. 89).

**Section XIV. CRANE ENGINE INTAKE AND EXHAUST SYSTEM**

**172. General**

The six intake and six exhaust valves are located in the cylinder block on the right side of the engine and are raised and lowered by tappets in contact with the camshaft. Adjusting screws in the tappets provide the means of adjusting the valve clearance. The stem of each valve rides within a valve guide pressed in the block. Intake valves control the admission of the fuel-air mixture to the cylinders, while the exhaust valves permit the expulsion of the exhaust gases from the cylinder. The crane engine intake and exhaust system consists of the intake and exhaust manifolds, muffler, and exhaust pipe. The intake manifold provides an individual passage for each cylinder to deliver the fuel-air mixture from the carburetor. The exhaust manifold carries the

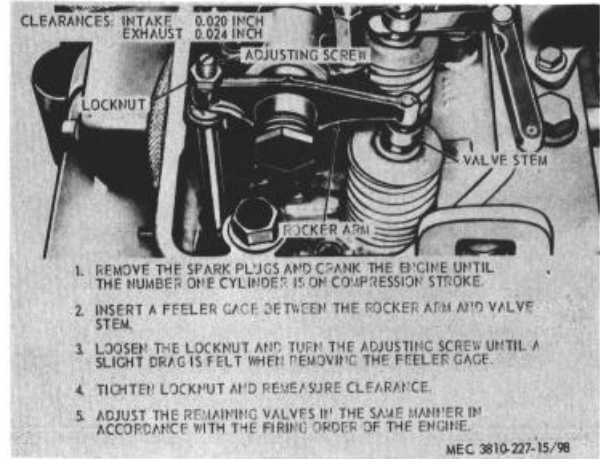

**Figure 98. Valve clearance, adjustment.**

- (3) Install the breather tube on the valve cover assembly (para. 160).

**171. Valve Clearance Adjustment**

- a. Remove the rocker arm valve covers (para. 170).
- b. Adjust the intake and exhaust valve clearances as instructed on figure 98.
- c. Install the front and rear valve covers (para. 170).

exhaust gases from the combustion chambers to the muffler and discharges them into the atmosphere.

**173. Valve Cover Assembly**

- a. *Removal and Installation.* Remove and install the valve cover assembly as instructed on figure 99.
- b. *Cleaning and Inspection.*
  - (1) Clean all parts with an approved cleaning solvent. Remove the old gasket from the valve cover.
  - (2) Inspect the valve cover for cracks, breaks, bends, and other damage. Replace defective cover and gasket.

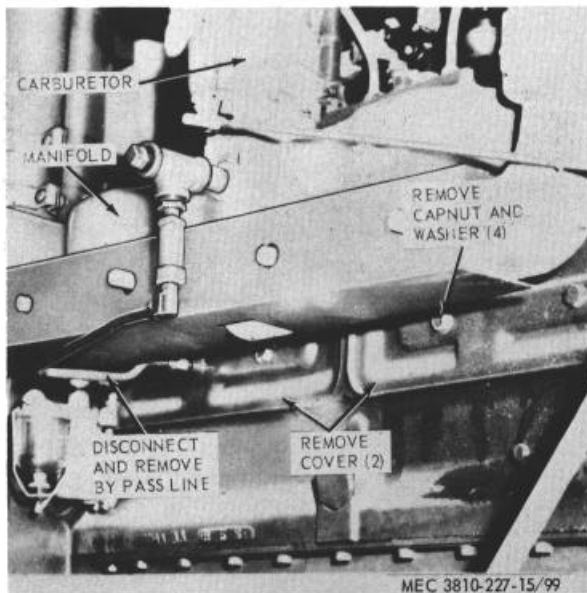

**Figure 99. Valve cover assembly, removal and installation.**

- (3) Inspect the bypass line for cracks, breaks, and other damage. Replace defective bypass line.

#### 174. Valve Adjustment

- a. Remove the valve covers from the engine (para. 173).

- b. Start the engine, allowing it to heat to normal operating temperature.
- c. Adjust the valves as instructed on figure 100.
- d. Install the valve covers (para. 173).
- e. The compression test is as follows:
  - (1) Remove the spark plug (para. 100).
  - (2) Place a suitable cylinder compression tester in the spark plug hole and crank the engine with the starter.
  - (3) The compression gage reading should be from 80 to 85 psi.
  - (4) Install the spark plug (para. 100).
  - (5) Test the remaining cylinders in a similar manner.

#### 175. Muffler and Pipe

- a. *Removal.* Remove the exhaust pipe and muffler as instructed on figure 101.
- b. *Cleaning and Inspection.*
  - (1) Clean the muffler and exhaust pipe with a wire brush.
  - (2) Inspect the muffler and exhaust pipe for breaks, bends, burned out condition, and other damage. Replace defective muffler and exhaust pipe.

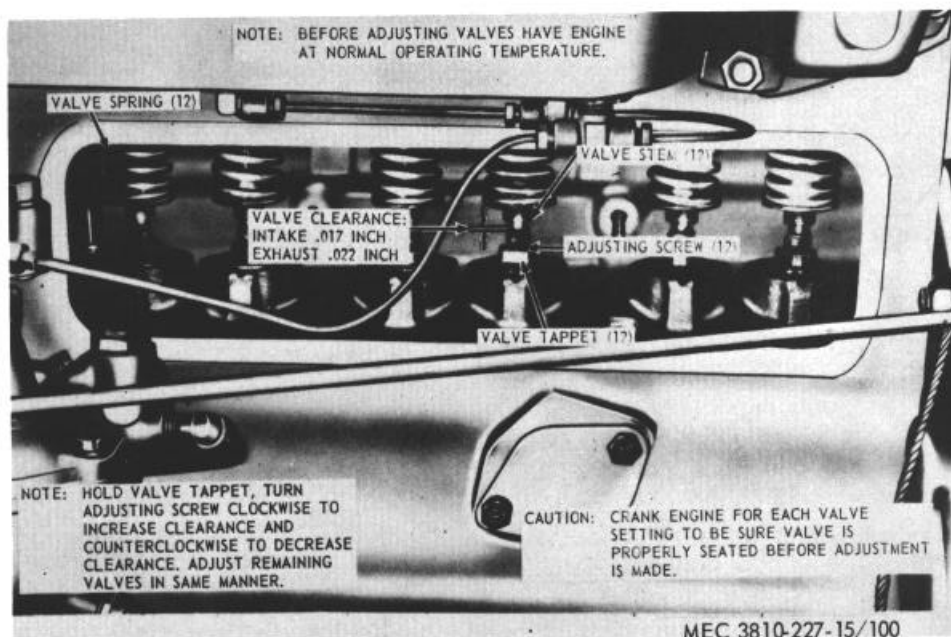

**Figure 100. Crane engine, valve adjustment.**

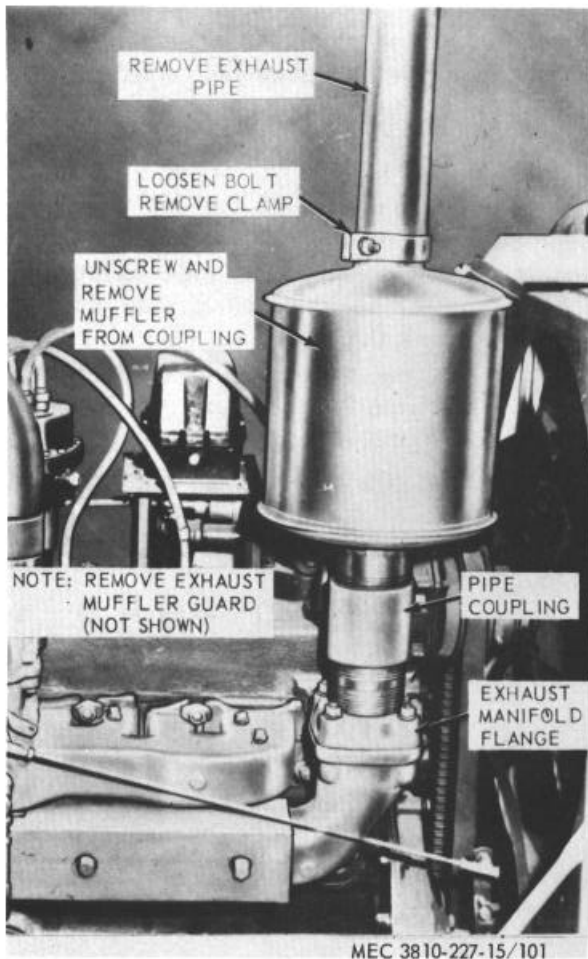

**Figure 101. Exhaust pipe and muffler, removal and installation.**

*c. Installation.* Install the muffler and exhaust pipe as illustrated on figure 101.

## 176. Intake and Exhaust Manifolds

### *a. Removal.*

- (1) Remove the exhaust pipe and muffler (para. 175).
- (2) Remove the carburetor (para. 93).

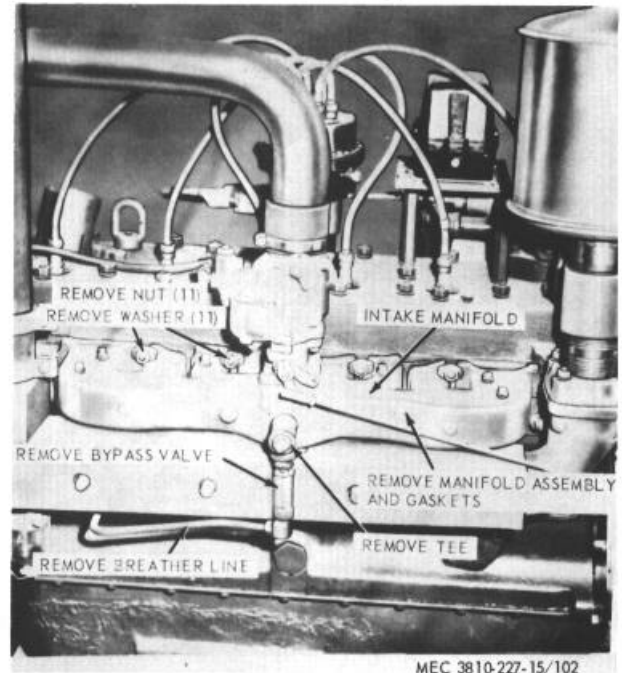

**Figure 102. Manifolds, removal and installation.**

- (3) Remove the intake and exhaust manifolds as instructed on figure 102.

### *b. Cleaning and Inspection.*

- (1) Clean the manifolds with a wire brush.
- (2) Inspect the manifolds for cracks, breaks, and other damage. Replace defective manifolds, gaskets, and mounting hardware.

### *c. Installation.*

- (1) Install the manifolds as illustrated on figure 102.
- (2) Install the carburetor (para. 93).
- (3) Install the muffler and exhaust pipe (para. 176).

## Section XV. CARRIER ENGINE CLUTCH ASSEMBLY

### 177. General

The carrier engine clutch is a double-plate, dry disc, adjustable, pull type, multiple lever design. No special tools are required for maintenance. Adjustment is

accomplished by turning the threaded adjusting ring to compensate for facing wear. The clutch is operated by mechanical linkage from the operator's cab. This mechanical linkage must be kept in adjustment.

**AGO 6819A**

## 178. Clutch Adjustment

### Note

**Make the internal clutch adjustment first and then check and reset external linkage, if required. Adjusting the external clutch linkage to restore the original free pedal movement will not compensate for an improperly adjusted clutch.**

#### a. Adjustment.

- (1) Remove the inspection cover at bottom of clutch housing (C, fig. 103).
- (2) Measure clearance between release bearing housing and spring plate hub (A, fig. 103). If clearance is more or less than specified ( $19/32$  inch  $\pm 1/32$  inch), readjust clutch as follows:
- (3) Rotate engine flywheel until adjusting ring lock (27 B, fig. 103) is exposed. Remove lock capscrew (26) and lock (27).
- (4) Release the clutch by locking the clutch pedal down in the depressed position.
- (5) Use a pry bar to turn adjusting ring (17). Turn adjusting ring counterclockwise to

move release bearing housing, toward flywheel; clockwise to move bearing housing away from flywheel. Rotation or movement of one lug position will move the release bearing housing approximately  $1/32$  inch.

- (6) Remove the clutch pedal block to reengage the clutch.
- (7) Recheck the clearance as outlined in (2) above.
- (8) After clutch has been properly adjusted, install lock (27) with lock screw (26) in notch provided in adjusting ring.
- (9) Check the clearance between release yoke fingers and release bearing housing pads. This clearance should be approximately  $1/8$  inch. It is important that  $1/8$  inch clearance be provided to allow for facing wear and clutch free pedal.

### Note.

**When clutch is properly adjusted, the free pedal should be approximately 1 1/2% inches.**

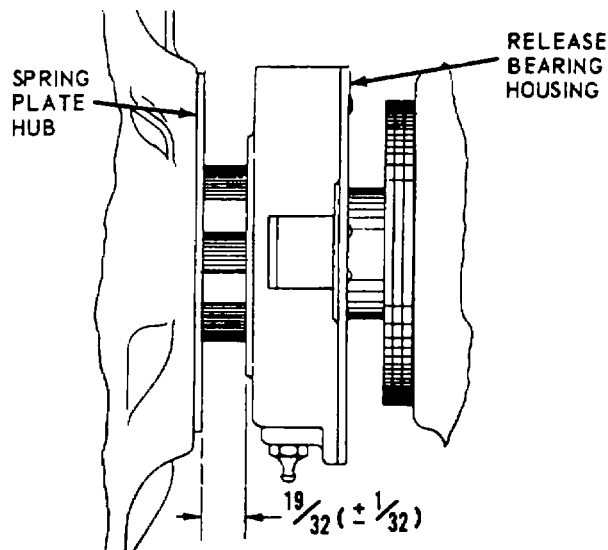

A - Clutch Adjustment Measurement

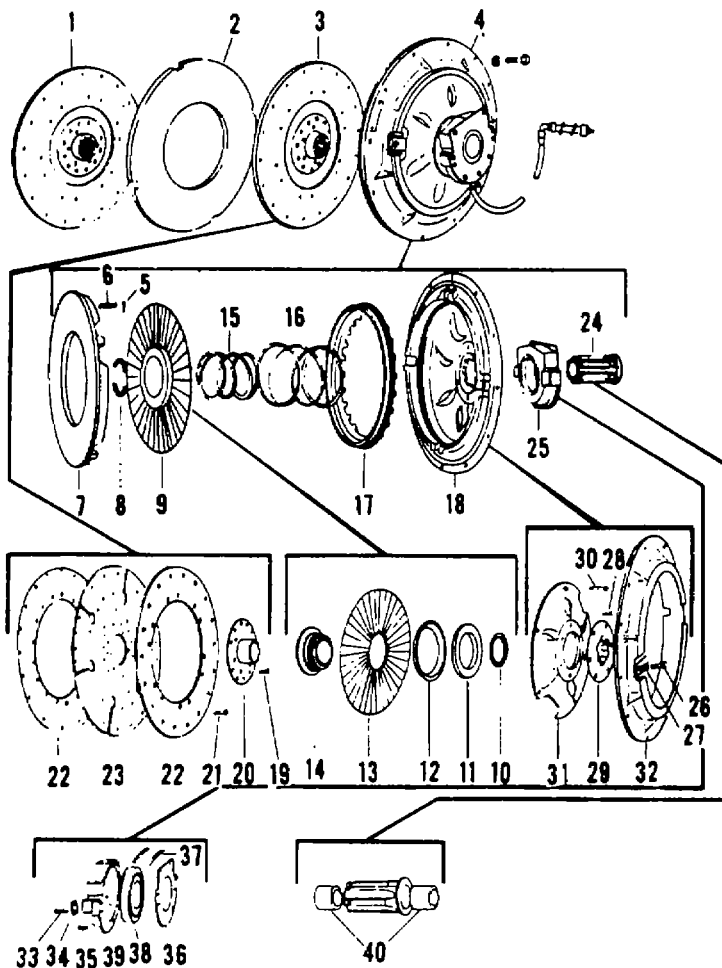

- 1 Driven disc ay. (front)
- 2 Intermediate pressure plate
- 3 Driven disc ay (rear)
- 4 Flywheel plate & hub ay
- 5 Pull-back spring anchor
- 6 Pull-back spring
- 7 Pressure plate
- 8 Split ring
- 9 Retainer & lever sub-ay
- 10 Spring ring retainer
- 11 Spring ring
- 12 Lever fulcrum ring
- 13 Clutch lever
- 14 Release sleeve retainer
- 15 Pressure spring (inner)
- 16 Pressure spring (outer)
- 17 Adjusting ring
- 18 Ring & plate sub-ay
- 19 Clutch hub rivet
- 20 Clutch hub
- 21 Clutch facing rivet
- 22 Clutch facing
- 23 Clutch disc
- 24 Release sleeve sub-ay
- 25 Release brg. & hsg. ay
- 26 Adjusting ring lock screw
- 27 Adjusting ring lock
- 28 Spring plate hub rivet
- 29 Spring plate hub
- 30 Spring plate rivet
- 31 Spring plate
- 32 Flywheel ring
- 33 Rivet (long)
- 34 Release yoke thrust plate
- 35 Rivet (short)
- 36 Release brg. hsg. cover
- 37 Release bearing spring
- 38 Release bearing
- 39 Release bearing housing
- 40 Release sleeve bushing

B - Clutch Assembly

MEC 3810-227-15/103 ①

Figure 103. Carrier engine clutch adjustment.

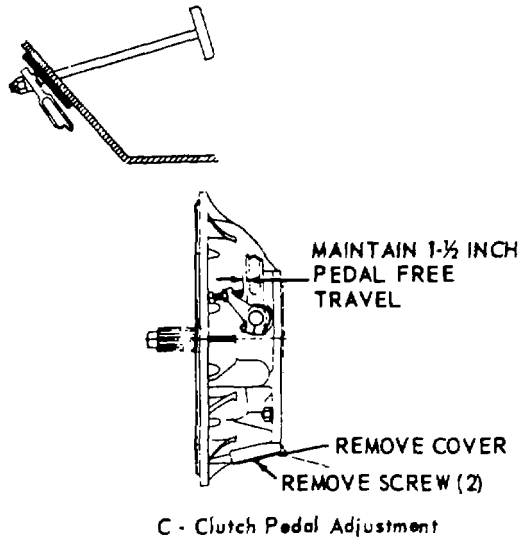

MEC 3810-227-15/103 ②

Figure 103. Continued.

## Section XVI. CRANE HYDRAULIC SYSTEM

### 179. General

Each hydraulic controller lever is mechanically connected to a master cylinder. Each master cylinder is connected to a hydraulic cylinder by a hydraulic line, and in turn each cylinder is connected to a clutch by a mechanical linkage. Movement of a lever actuates the position in the corresponding cylinder. Actuation of a piston in the cylinder causes hydraulic pressure in the connecting line and cylinder. As a result, a piston in the cylinder is actuated and in turn actuates the clutch through cylinder linkage. When pressure is released, a return spring causes the cylinder piston to return to its normal position, and fluid is returned through the connecting line to the master cylinder.

### 180. Master Cylinder

#### a. Removal.

- (1) Drain master cylinder.
- (2) Remove the master cylinder as instructed on figure 104.

#### b. Cleaning, Inspection, and Repair.

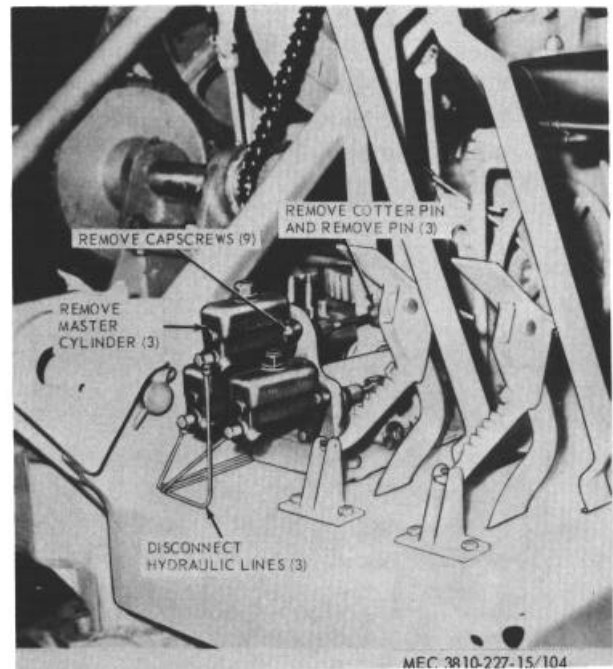

Figure 104. Hydraulic master cylinder, removal and installation.

#### Caution

Make sure the working area is clean and dust-free wherever hydraulics or their principles are involved. Cleanliness is



**the greatest factor of good hydraulic operation.**

- (1) Clean all parts with an approved cleaning solvent.
- (2) Inspect all parts for breaks, leaks, and other damage. Replace as necessary.

**c. Installation.**

- (1) Install the hydraulic master cylinder as illustrated on figure 104.
- (2) Fill the master cylinder with hydraulic oil to 1/4 inch from top.
- (3) Bleed the hydraulic system (para. 183).

**181. Hoist Drum Shaft Clutch Hydraulic Cylinders**

**a. Removal.**

- (1) Drain boom hoist clutch hydraulic cylinder.
- (2) Remove the boom hoist clutch hydraulic cylinder as instructed on figure 105.

**b. Cleaning, Inspection, and Repair.**

- (1) Clean all parts with an approved clearing solvent.
- (2) Inspect all parts for breaks, leaks, and other damage. Repair or replace all defective parts.

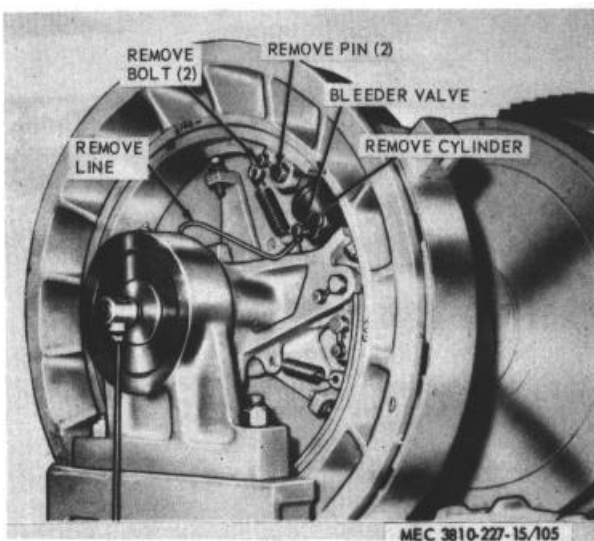

**Figure 105. Hoist drum shaft clutch hydraulic cylinder, removal and installation.**

**c. Installation.**

- (1) Install the boom hoist clutch hydraulic cylinder as illustrated on figure 105.
- (2) Add hydraulic fluid to master cylinder for boom hoist clutch to 1/4 inch from top.
- (3) Bleed the boom hoist clutch hydraulic cylinder and lines (para. 183).

**182. Shaft Packing Gland**

**a. Removal.** Remove the shaft packing gland as instructed on figure 106.

**b. Disassembly.** Disassemble the shaft packing gland as illustrated on figure 107.

**c. Cleaning, Inspection, and Repair.**

- (1) Clean all parts with an approved cleaning solvent.
- (2) Inspect all parts for cracks, leaks, excessive wear, and other damage. Repair or replace all defective parts.

**d. Reassembly.** Reassemble the shaft packing gland as illustrated on figure 107.

**e. Installation.**

- (1) Install the shaft packing gland as illustrated on figure 106.
- (2) Bleed packing gland and lines (para. 183).

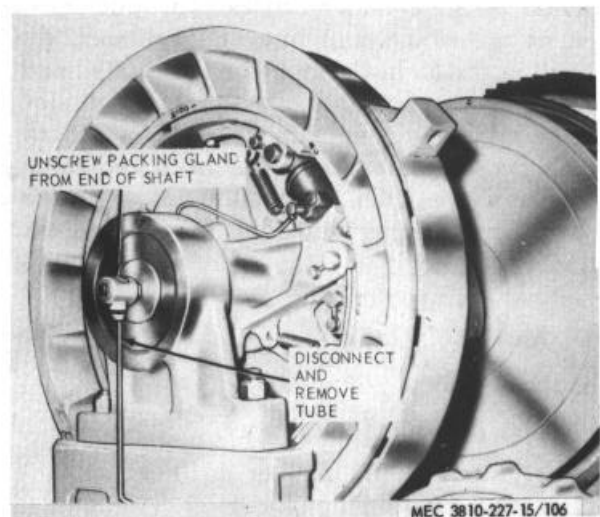

**Figure 106. Packing gland, removal and installation.**

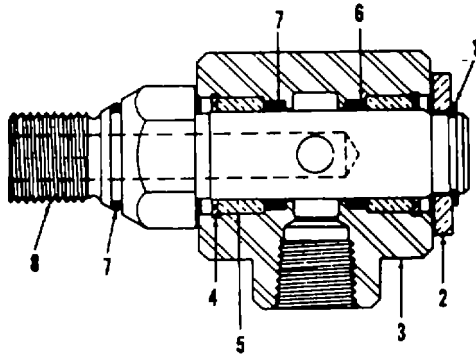

MEC 3810-227-15/107

- |                 |                  |
|-----------------|------------------|
| 1 Snap ring     | 5 Sleeve bearing |
| 2 Thrust washer | 6 Backup washer  |
| 3 Housing       | 7 O ring         |
| 4 Snap ring     | 8 Rotor          |

**Figure 107. Crane packing gland assembly.**

### 183. Hydraulic Tubes and Fittings

#### a. Removal.

- (1) Drain lines and master cylinder.
- (2) Remove the hydraulic tubes and fittings as instructed on figure 108.

#### b. Cleaning, Inspection, and Repair.

- (1) Clean all parts with an approved cleaning solvent.
- (2) Inspect all parts for cracks, breaks, leaks, and other damage. Replace all parts as necessary.

#### c. Installation.

- (1) Install the hydraulic tubes and fittings as illustrated on figure 108.
- (2) Bleed the hydraulic system as in *d* below.

#### d. Bleeding Hydraulic System.

- (1) Fill the master cylinder to 1/4 inch from top.
- (2) Fully engage the hand lever which is affected and leave it engaged.
- (3) Loosen bleeder valve on the hydraulic cylinder affected and allow air to escape.
- (4) Tighten the bleeder valve before releasing the hand lever, so no air will be drawn into the hydraulic cylinder.
- (5) Engage lever for proper operation.
- (6) Repeat (1) through (5) above until hydraulic line and cylinder are fully bled.
- (7) Repeat (1) through (6) above for bleeding all hydraulic cylinders and lines.

**Note. Recheck master cylinder and fill to proper level.**

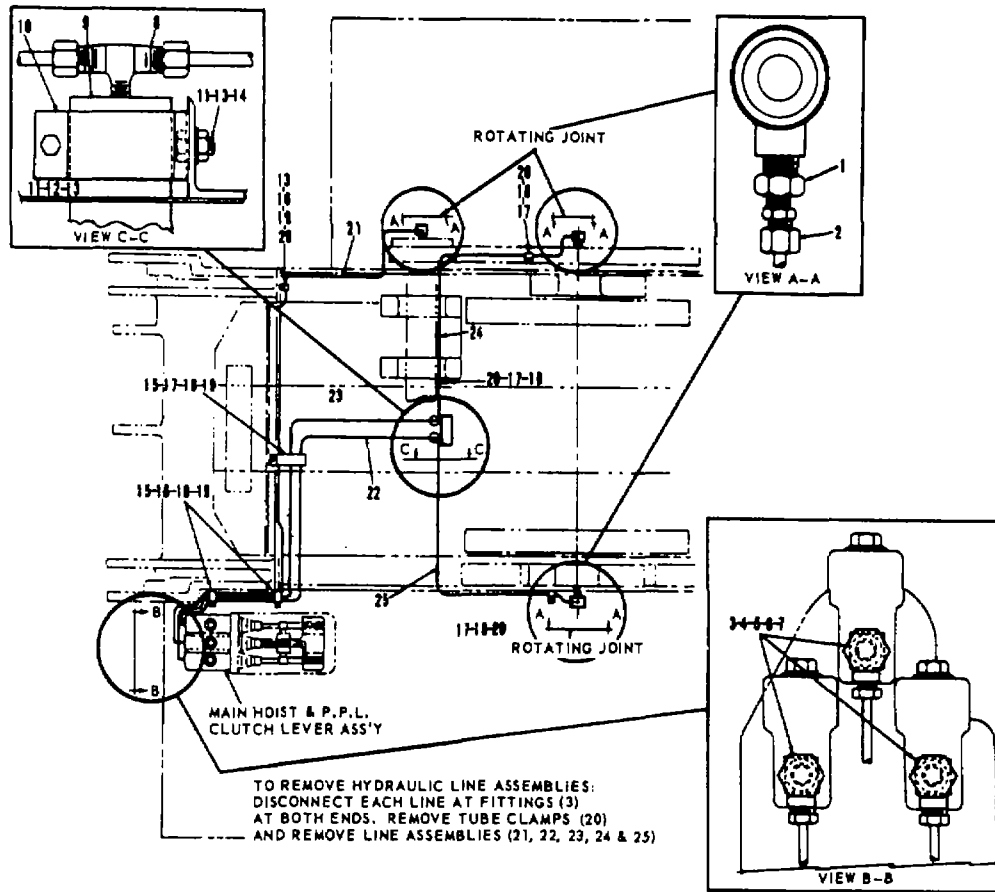

MEC 3810-227-15/108

1 Bushing	6 Copper washer	11 Nut	16 Screw	21 Tube
2 Union, tube half	7 Nut, tube	12 Capscrew	17 Screw	22 Tube
3 Connector bolt	8 Tee, tube	13 Lockwasher	18 Lockwasher	23 Tube
4 Connector	9 Accumulator	14 Capscrew	19 Screw	24 Tube
5 Copper washer	10 Hanger	15 Clamp, tube	20 Tube clamp	25 Tube

Figure 108. Hydraulic tubes and fittings, removal and installation.

## Section XVII. CRANE CLUTCH AND BRAKE ASSEMBLIES CONTROLS AND LINKAGE

### 184. General

The operating clutches are of the internal expanding type. The band assemblies are composed chiefly of a clutch shoe with lining, a clutch actuating arm and actuating arm retracting spring, and a band retracting spring. The brakes are of the external-contracting type mounted on the outside of the clutch drums. They consist chiefly of a two-part hinged-attached brake assembly with lining. One end of the band assembly is anchored and the other is actuated.

### 185. Crane Engine Clutch Adjustment

Adjust the engine clutch as shown in figure 109.

### 186. Boom Independent Hoist Shaft Clutch

#### a. Adjustment.

- (1) Loosen adjusting nut (33, A, fig. 110) nearest the end of the eyebolt, and run the other adjusting nut (34) tight against the swivel pin. Be sure nuts are tight after adjustment is made.

AGO 6819A

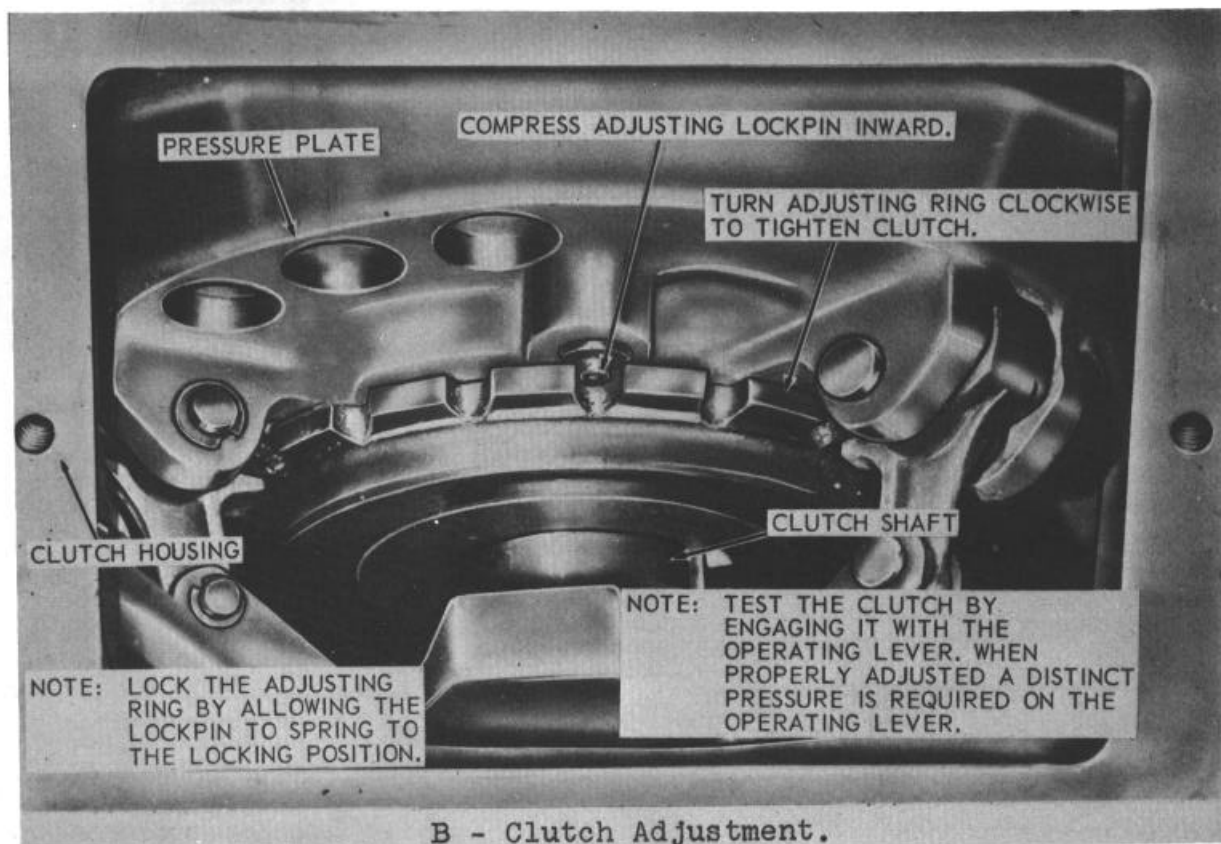
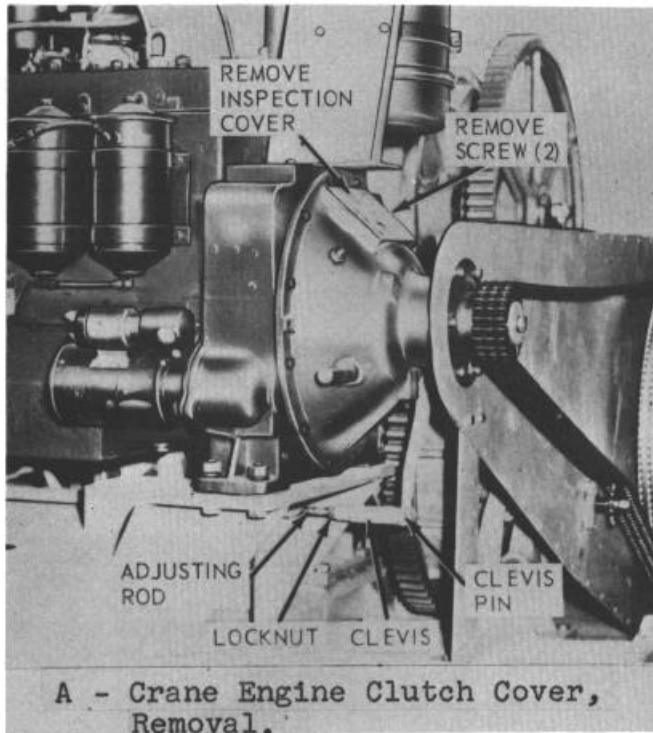

MEC 3810-227-15/109

Figure 109. Crane engine clutch adjustment.

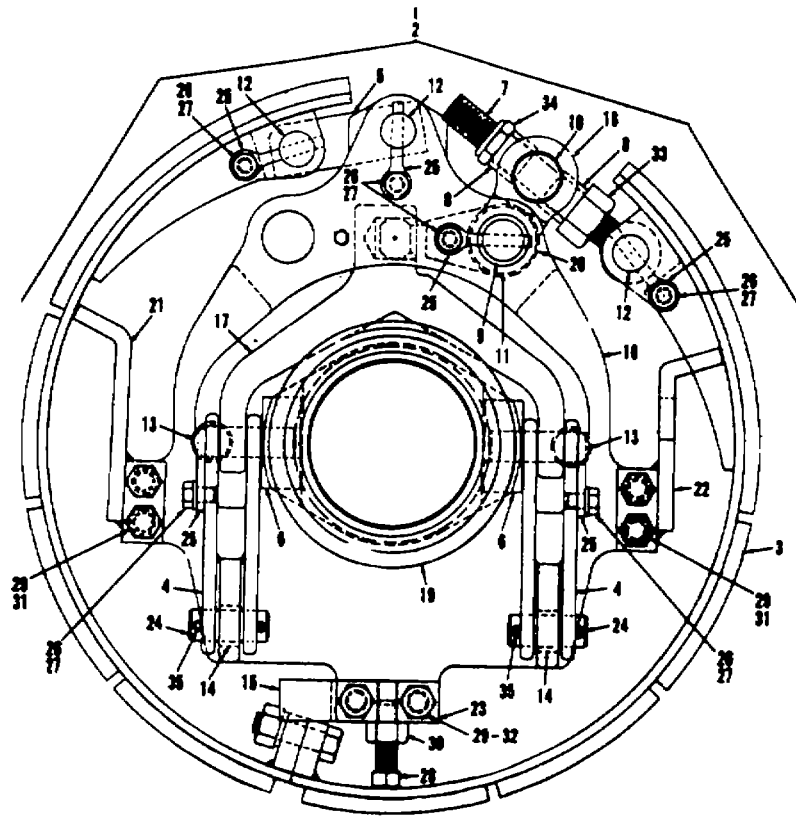

A - Toggle clutch

- 1 R. H. clutch assembly
- 2 L. H. clutch assembly
- 3 Band assembly
- 4 Toggle link
- 5 Dead link
- 6 Shifting shoe
- 7 Adjusting screw
- 8 Spacer
- 9 Lever bushing
- 10 Pivot pin
- 11 Lever pin
- 12 End pin
- 13 Yoke pin
- 14 Bushing
- 15 Keeper
- 16 Spider
- 17 Toggle yoke
- 18 Live lever
- 19 Shifting collar
- 20 Shim
- 21 Adj. bar
- 22 Adj. bar
- 23 Adj. bar
- 24 Pin
- 25 Lock pin
- 26 Capscrew, hex. hd.
- 27 Washer, lock
- 28 Setscrew, sq. hd.
- 29 Capscrew, hex. hd.
- 30 Nut
- 31 Washer, lock
- 32 Washer, lock
- 33 Nut
- 34 Nut
- 35 Pin, cotter

A—Toggle clutch

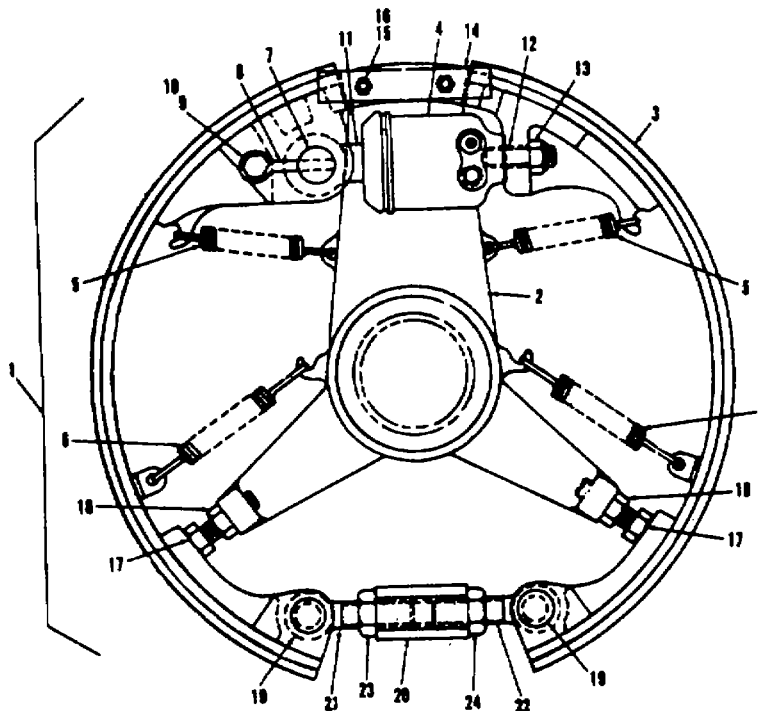

B - Clutch assembly

- 1 Clutch assembly
- 2 Spider
- 3 Clutch band assembly
- 4 Cylinder
- 5 Spring
- 6 Spring
- 7 Pin
- 8 Pin, lock
- 9 Capscrew, hex. hd.
- 10 Washer, lock
- 11 Rod, push
- 12 Stud
- 13 Nut, self locking
- 14 Bar
- 15 Capscrew, hex. hd.
- 16 Washer, lock
- 17 Capscrew, hex. hd.
- 18 Nut, jam
- 19 Yoke pin assembly
- 20 Bar, hex
- 21 Bolt, eye, LH thd.
- 22 Bolt, eye, RH thd.
- 23 Nut, jam
- 24 Nut, jam

B—Clutch assembly

MEC 3810-227-15/110 ①

Figure 110. Clutch band adjustment, removal and installation.

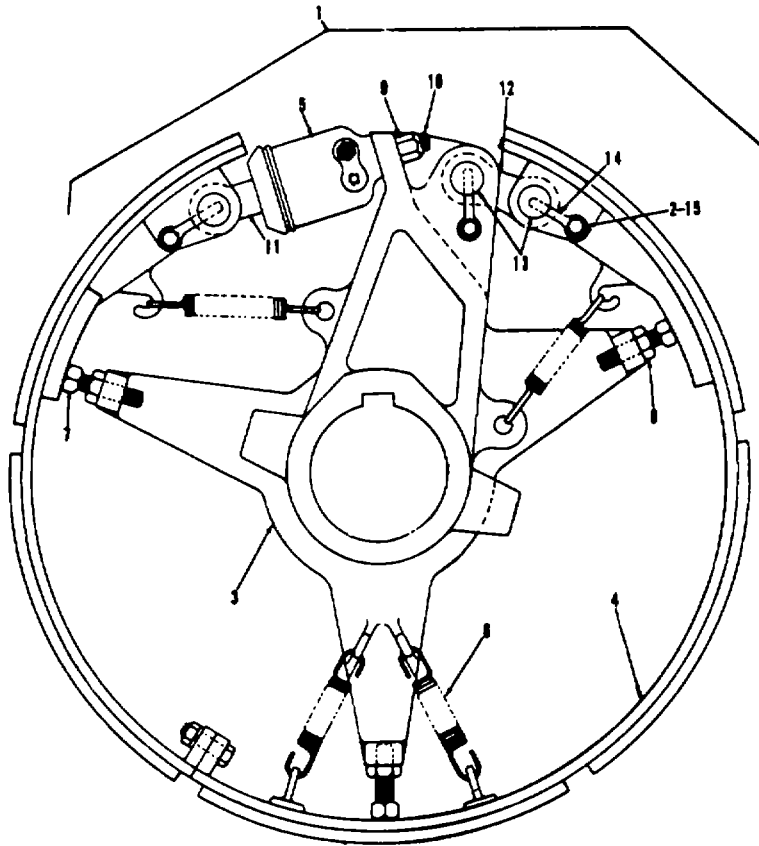

- 1 Clutch assembly
- 2 Lockwasher
- 3 Spider
- 4 Band assembly
- 5 Cylinder
- 6 Spring
- 7 Setscrew
- 8 Jam nut
- 9 Locking nut
- 10 Stud
- 11 Push rod
- 12 Link
- 13 Pin
- 14 Lock pin
- 15 Capscrew

C—Hoist Clutch Assembly

C - Hoist Clutch Assembly.

MEC 3810-227-15/110 ②

Figure 110 - Continued.

- (2) Adjust clutch band release stops (21, 22, and 30) to allow approximately  $\frac{1}{2}$  inch clearance between band and stops with clutch engaged.
- (3) The band lining should never be allowed to drag on the drums, when clutch is fully disengaged. Check clutch bands periodically.

b. *Removal.* Remove the clutch bands as shown in figure 110.

c. *Cleaning and Inspection.*

- (1) Clean all parts with an approved cleaning solvent and dry thoroughly.
- (2) Inspect clutch band lining for excessive wear and glazing. Remove glazing with a wire brush. Bands should be replaced before rivet heads rub against drum. Replace a clutch band having worn or

defective lining.

- (3) Inspect all other parts for breaks, cracks or other damage. Replace all defective parts.

d. *Installation.*

- (1) Install the clutch bands as shown in figure 110.
- (2) IMPORTANT, make sure the clutch is assembled correctly. When looking into the clutch with adjustment to the top, the dead end should be on the left-hand side.
- (3) Adjust clutches as in a above.

### 187. Left-Hand Horizontal Reversing Shaft Clutch

Adjust, remove and install the left-hand reversing clutch in the same manner as the boom independent hoist clutch (para. 186).

**Note.**

**When installing the clutch, looking into the clutch with the adjustment at the top, the dead end should be on the left-hand side.**

### 188. Right-Hand Horizontal Reversing Shaft Clutch

Adjust, remove and install the right-hand reversing clutch in the same manner as the boom hoist drum clutch (para. 186).

**Note.**

**When installing the clutch, looking into the clutch with the adjustment at the top, the dead end should be on the right-hand side.**

### 189. Hoist Drum Shaft Clutches (Left-Hand and Right-Hand)

*a. Adjustment.*

- (1) With control lever in neutral position, loosen the nuts (18, B, fig. 110) on the equalizer screws (17).
- (2) Adjust the equalizer screws until there is 1/32 inch clearance between the clutch drum and clutch lining at each point.
- (3) Tighten the lock nuts.

*b. Removal.*

- (1) Remove the hydraulic cylinder (para. 181).
- (2) Remove the clutch bands as instructed on figure 110.

*c. Cleaning and Inspection.*

- (1) Clean all parts with an approved cleaning solvent.
- (2) Inspect clutch band for excessive wear and glazing. Remove glazing with a wire brush. Replace a clutch band having worn or defective lining.
- (3) Inspect all other parts for breaks, cracks, and other damage. Replace all defective parts.

*d. Installation.*

- (1) Install the clutch bands as illustrated on figure 110.
- (2) Install the hydraulic cylinder (para. 181).

- (3) Adjust the clutch band as instructed in a above.

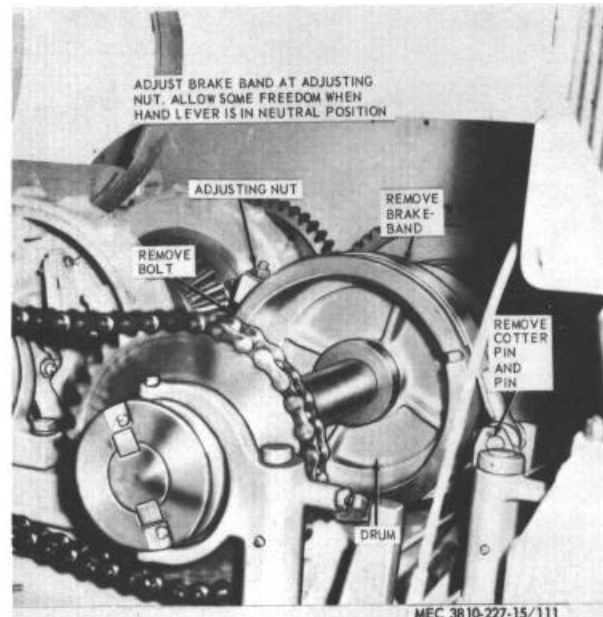

**Figure 111. Boom hoist brake band adjustment, removal and installation.**

### 190. Power Load Lowering Clutch

Adjust, remove and install the power load lowering clutch in the same manner as the hoist drum clutches (para. 189).

### 191. Boom Hoist Brakeband

*a. Adjustment.*

- (1) Adjust the boom hoist brakeband shown in figure 111.
- (2) As lining wears, make adjustment at the bolt on top of the brakeband.

*b. Removal and Installation.* Remove and install the brakeband as shown in figure 111.

*c. Cleaning and Inspection.*

- (1) Clean all parts with an approved cleaning solvent and dry thoroughly.
- (2) Inspect the lining for excessive wear, glazing, and other damage. Replace a brake band having a defective lining.
- (3) Inspect all other parts for excessive wear, breaks, and other damage. Replace parts and brakeband as necessary.

AGO 6819A

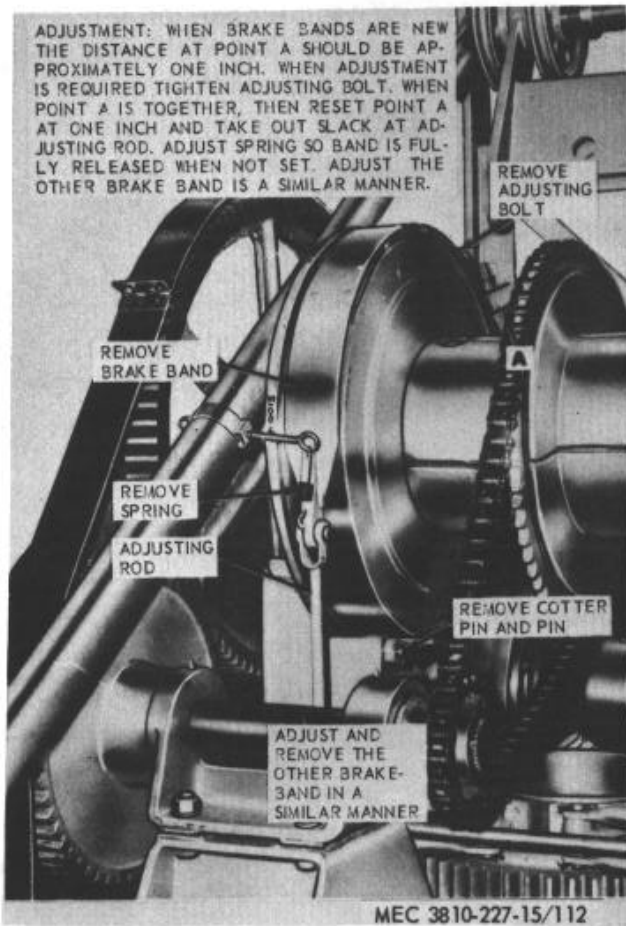

**Figure 112. Hoist brakeband adjustment, removal and installation.**

## 192. Hoist Brakebands

*a. Adjustment.* Adjust hoist brakebands as shown in figure 112.

*b. Removal and Installation.* Remove and install the brakebands as shown in figure 112.

*c. Cleaning and Inspection.*

- (1) Clean all parts in an approved cleaning solvent and dry thoroughly.
- (2) Inspect the lining for excessive wear, glazing and other damage. Replace a brakeband having defective lining.
- (3) Inspect all other parts for excessive wear, breaks, and other damage. Replace parts and brakeband as necessary.

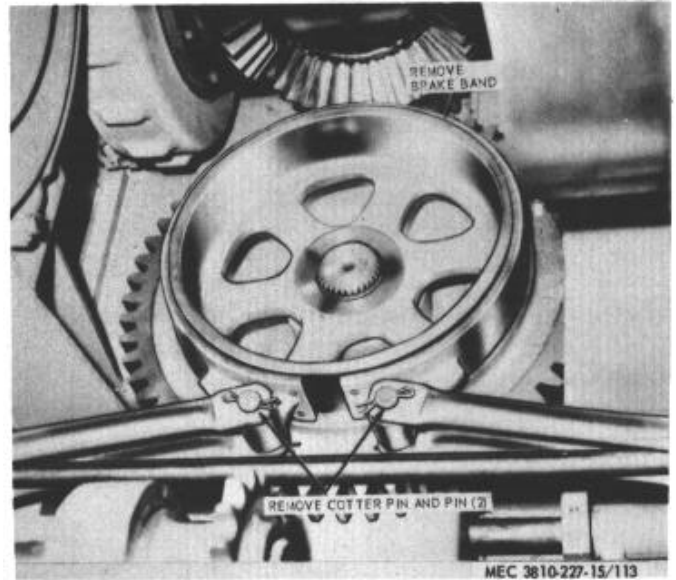

**Figure 113. Swing brake, removal and installation.**

## 193. Swing Brake and Linkage

*a. Adjustment.* The swing brake is not designed for adjustment.

*b. Removal and Installation.* Remove and install swing brake as shown in figure 113.

*c. Cleaning and Inspection.*

- (1) Clean all parts in an approved cleaning solvent.
- (2) Inspect brake lining for excessive wear, glazing, and other damage. Replace a brakeband having defective lining.
- (3) Inspect all parts for breaks, excessive wear, and other damage. Replace all defective parts.

## 194. Cab Lock Assembly

*a. Removal and Installation.* Remove and install cab lock assembly as instructed on figure 114.

*b. Cleaning, Inspection, and Repair.*

- (1) Clean all parts with an approved cleaning solvent.
- (2) Inspect all parts for breaks, bends, excessive wear, and other damage. Repair or replace parts as necessary.



## Section XVIII. PRIMARY DRIVE ASSEMBLY AND GEAR GUARDS

### 195. General

The primary drive chain assembly is inclosed by the drive chain case cover. The input sprocket and countershaft sprocket are connected by a multi-strand roller drive chain.

### 196. Primary Drive Chain Case Cover, Drive Chain, and Drive Gear

a. *Adjustment.* Adjust the drive chain as instructed in figure 115.

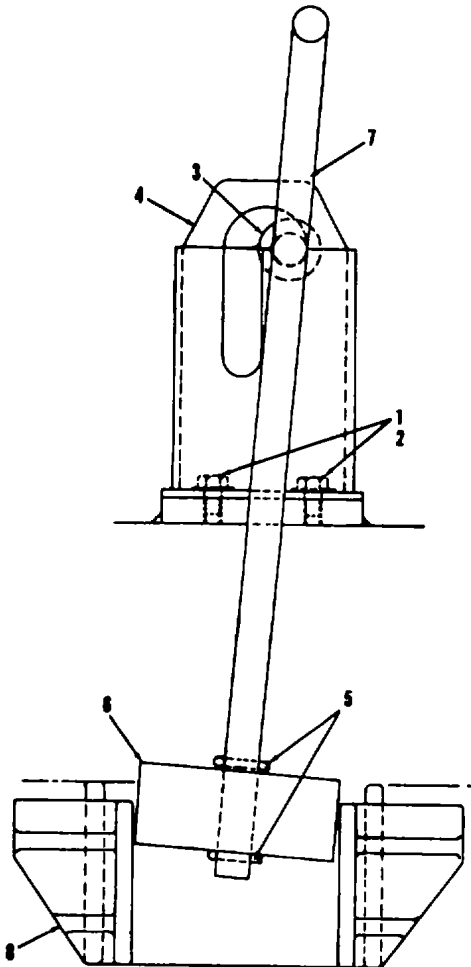

MEC 3810-227-15/114

- |                      |                  |
|----------------------|------------------|
| 1 Capscrew, hex. hd. | 5 Collar         |
| 2 Washer, lock       | 6 Bracket        |
| 3 Pin, cotter        | 7 Rod            |
| 4 Gear               | 8 Cab lock guide |

Figure 114. Cab lock assembly, removal and installation.

### Note.

**Before removal of drive chain case cover, drain the oil from the chain case.**

b. *Removal and Installation.* Remove and install the drive chain case cover, drive chain, and drive gear as instructed in figure 115.

c. *Cleaning and Inspection.*

- (1) Clean all parts with an approved cleaning solvent and dry thoroughly.
- (2) Inspect all parts for breaks, cracks, and other damage. Replace defective parts.

### 197. Gear Guards and Chain Guards

a. *Removal and Installation.* Remove and install guards as instructed in figure 116.

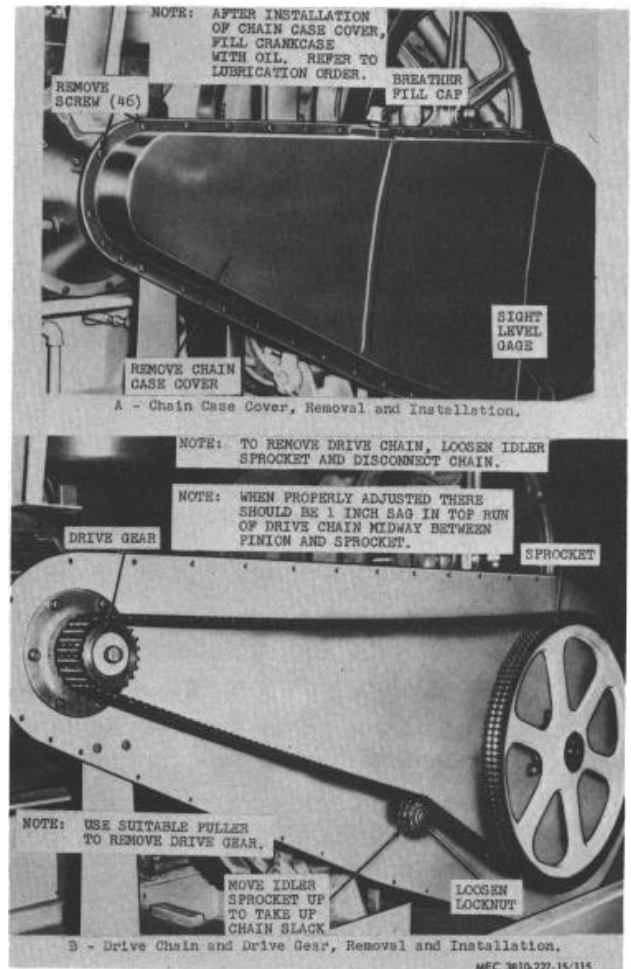

Figure 115. Primary drive chain case cover, drive chain, and drive gear, removal and installation.

AGO 6819A

b. *Cleaning and Inspection.*

- (1) Clean all parts with an approved cleaning solvent and dry thoroughly.

- (2) Inspect all parts for breaks, cracks, and other damage. Replace defective parts.

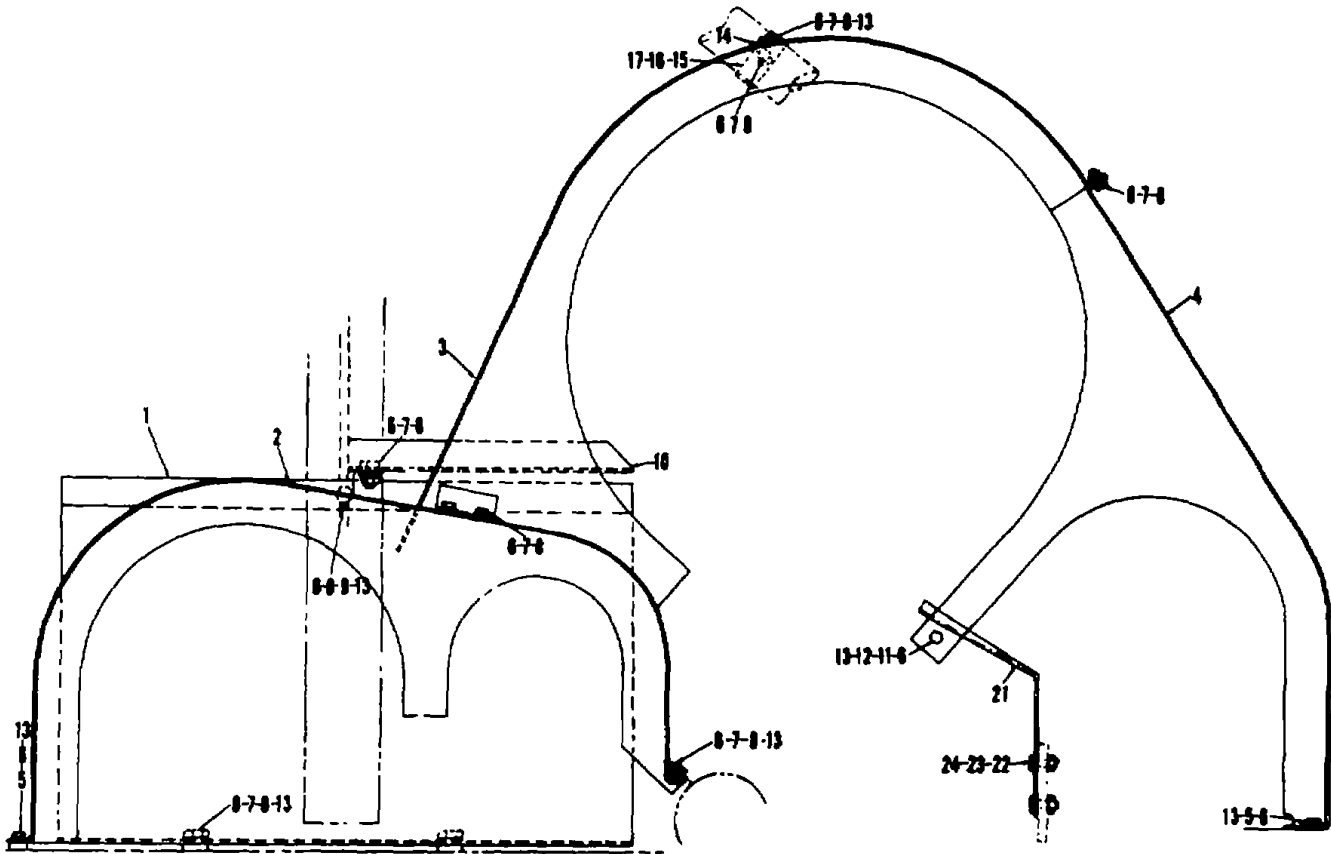

MEC 3810-227-15/116

- |   |                             |                                    |
|---|-----------------------------|------------------------------------|
| 1 Boom hoist guard                        | 9 Capscrew                  | 18 } Not used                      |
| 2 Reverse shaft and boom hoist gear guard | 10 Reverse bevel gear guard | 19 } Not used                      |
| 3 Main gear guard                         | 11 Capscrew                 | 20 } Not used                      |
| 4 Auxiliary gear guard                    | 12 Spacer                   | 21 Power load lowering chain guard |
| 5 Capscrew                                | 13 Washer                   | 22 Capscrew                        |
| 6 Lockwasher                              | 14 Bracket                  | 23 Lockwasher                      |
| 7 Capscrew                                | 15 Hanger                   | 24 Nut                             |
| 8 Nut                                     | 16 Capscrew                 |                                    |
|   | 17 Nut                      |                                    |

Figure 116. Gear and chain guards, removal and installation.

### Section XIX. LOAD ROLLER ASSEMBLY

#### 198. General

The crane is equipped with two sets of rollers. Two double rollers are mounted on the front of the revolving frame, and two single rollers are mounted in the rear. The rollers serve two functions, securing the crane assembly to the turntable and supporting the entire weight of the crane load.

#### 199. Front Load Rollers

##### a. Removal.

- (1) Place adequate cribbing between carrier frame and rear underside of main frame.
- (2) Remove the front load rollers as instructed on figure 117.

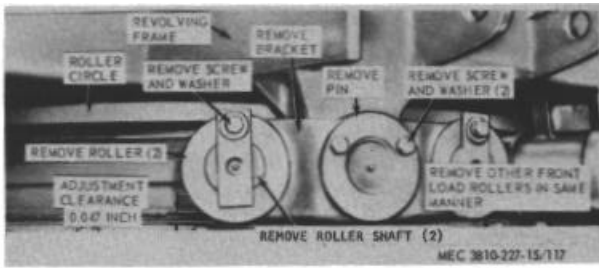
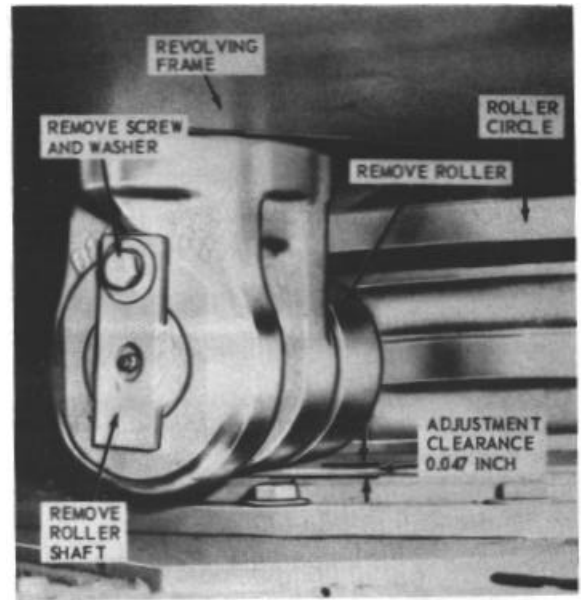
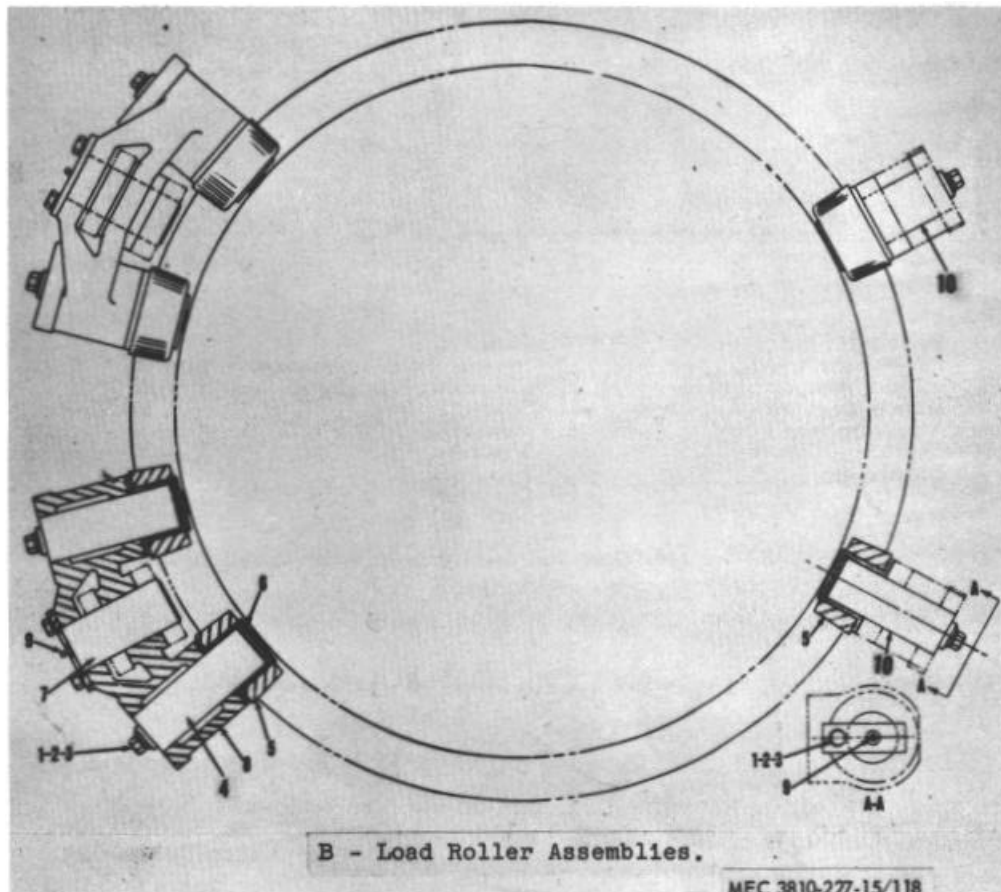

Figure 117. Front load rollers, removal, adjustment and installation.



A - Rear Load Rollers, Removal and Installation.



B - Load Roller Assemblies.

- |                    |                |               |                     |                 |
|--------------------|----------------|---------------|---------------------|-----------------|
| 1 Cap screw hex hd | 3 Washer plain | 5 Load roller | 7 Equalizer pin     | 9 Fitting lube  |
| 2 Washer lock      | 4 Roller shaft | 6 Bushing     | 8 Equalizer bracket | 10 Roller shaft |

Figure 118. Crane load rollers, removal, disassembly, reassembly, and installation.

AGO 6819A

b. *Disassembly.* Disassemble the front load rollers in numerical sequence as illustrated on figure 118.

c. *Cleaning and Inspection.*

- (1) Clean all parts with an approved cleaning solvent.
- (2) Inspect all parts for excessive wear, breaks, cracks, and other damage. Replace all defective parts.

d. *Reassembly.* Reassemble the front load rollers in the reverse sequence as illustrated on figure 118.

e. *Installation.* Install the front load rollers as illustrated on figure 117.

f. *Adjustment.* When installing the roller plates, install the required amount of shims to obtain 0.047 inch clearance between the rollers and roller circle.

## 200. Rear Load Rollers

a. *Removal.*

- (1) Place adequate cribbing between carrier

frame and rear underside of main frame.

- (2) Remove the rear load rollers as instructed on figure 118.

b. *Disassembly.* Disassemble the rear load rollers in numerical sequence as illustrated on figure 118.

c. *Cleaning and Inspection.*

- (1) Clean all parts with an approved cleaning solvent.
- (2) Inspect all parts for excessive wear, breaks, cracks, and other damage. Replace defective parts.

d. *Reassembly.* Reassemble the rear load rollers in the reverse sequence as illustrated on figure 118.

e. *Installation.* Install the rear load rollers as illustrated on figure 118.

f. *Adjustment.* Adjust rear load rollers in a manner similar to the adjustment of the front load rollers (para. 199).

## Section XX. SAFETY RATCHET AND JAW CLUTCH ASSEMBLIES

### 201. Safety Ratchet Assembly

a. *Removal and Installation.* Remove and install the safety ratchet and linkage as instructed in figure 119.

b. *Cleaning, Inspection, and Repair.*

- (1) Clean all parts with an approved cleaning solvent.
- (2) Inspect all parts for breaks, bends and other damage. Repair or replace defective parts as necessary.

### 202. Jaw Clutch Lever Linkage

a. *Removal and Installation.* Remove and install jaw clutch lever linkage as shown in figure 120.

b. *Cleaning, Inspection, and Repair.*

- (1) Clean all parts with an approved cleaning solvent.
- (2) Inspect the linkage for breaks, bends, and other damage. Repair or replace linkage as necessary.

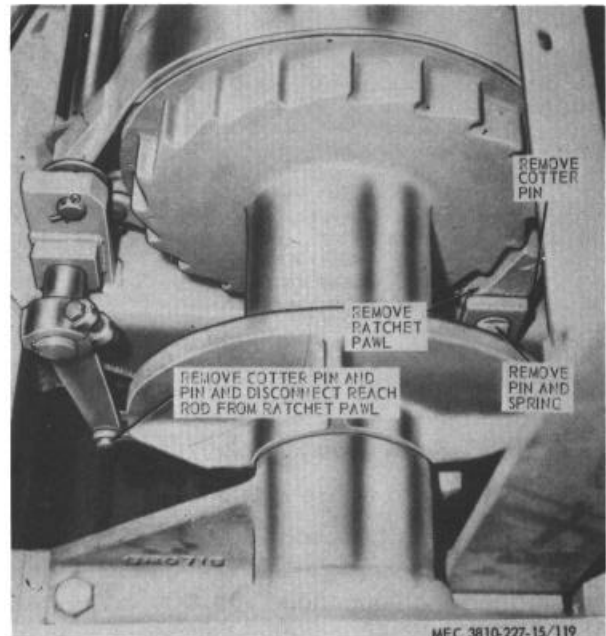
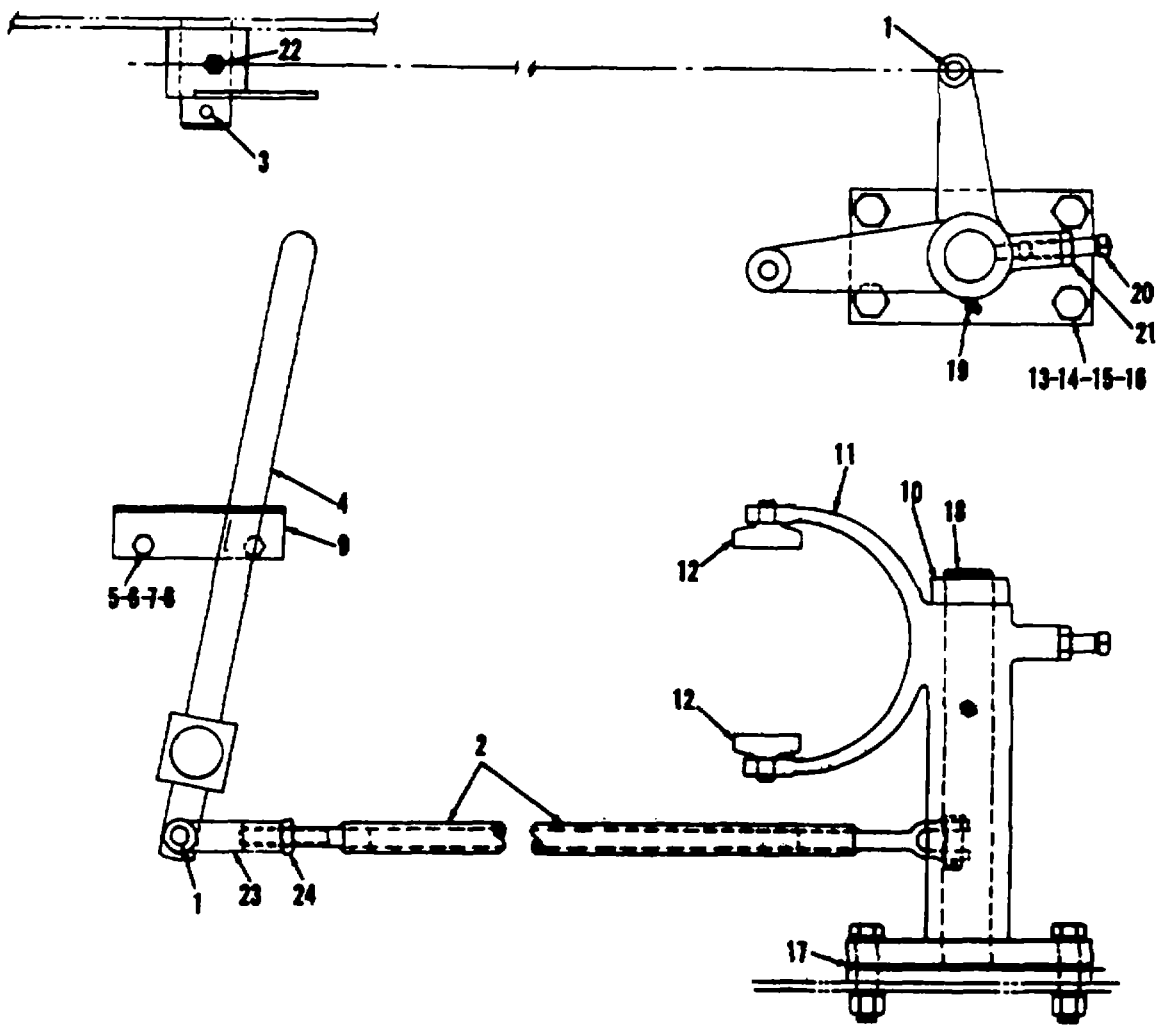

Figure 119. Safety ratchet assembly, removal and installation.



MEC 3810-227-15/120

- |                 |                 |                    |
|-----------------|-----------------|--------------------|
| 1 Clevis pin    | 9 Lever bracket | 17 Shim            |
| 2 Connector rod | 10 Collar       | 18 Shifter support |
| 3 Cotter pin    | 11 Shifter yoke | 19 Lube fitting    |
| 4 Lever         | 12 Shifter shoe | 20 Screw           |
| 5 Nut           | 13 Nut          | 21 Nut             |
| 6 Lockwasher    | 14 Lockwasher   | 22 Lube fitting    |
| 7 Capscrew      | 15 Capscrew     | 23 Clevis          |
| 8 Plain washer  | 16 Plain washer | 24 Nut             |

Figure 120. Jaw clutch lever linkage, removal and installation.

*c. Adjustment of Boom Hoist Control and Jaw Clutch-Boom Hot Brake Interlock.*

- (1) Refer to figure 121.
- (2) Engage the boom hoist safety ratchet and disengage the jaw clutch at left end of boom hoist shaft.
- (3) Adjust boom hoist brake band by tightening or loosening nut (7) so that pin (36) is only half visible from behind the supporting lug welded to the rotating deck.
- (4) Check spring (18) below the rotating deck to see that it is adjusted to 9 1/2 inch length.
- (5) Refer to figure 120 and adjust the stop screw (20) so that it just touches

AGO 6819A

the interlock lever (11, figure 121) on the boom hoist brake assembly. Be sure the lock nut (21, figure 120) is pulled up tight to hold the adjusting screw in position. The control system is now adjusted so

that the boom hoist brake, which is spring set, cannot be released and will keep the boom from falling when the jaw clutch is disengaged.

## Section XXI. CRANE BOOM, PULLEYS, AND PULLEY BUSHINGS

### 203. General

The boom for crane consists of two sections. The power boom section is connected by two footpins to the revolving frame. The upper boom section carries the boom point sheave assembly. The boom is of welded construction.

### 204. Crane Boom and Pulleys

#### a. Removal.

- (1) Remove all reeving from the crane boom.
- (2) Remove the crane boom from the revolving frame.

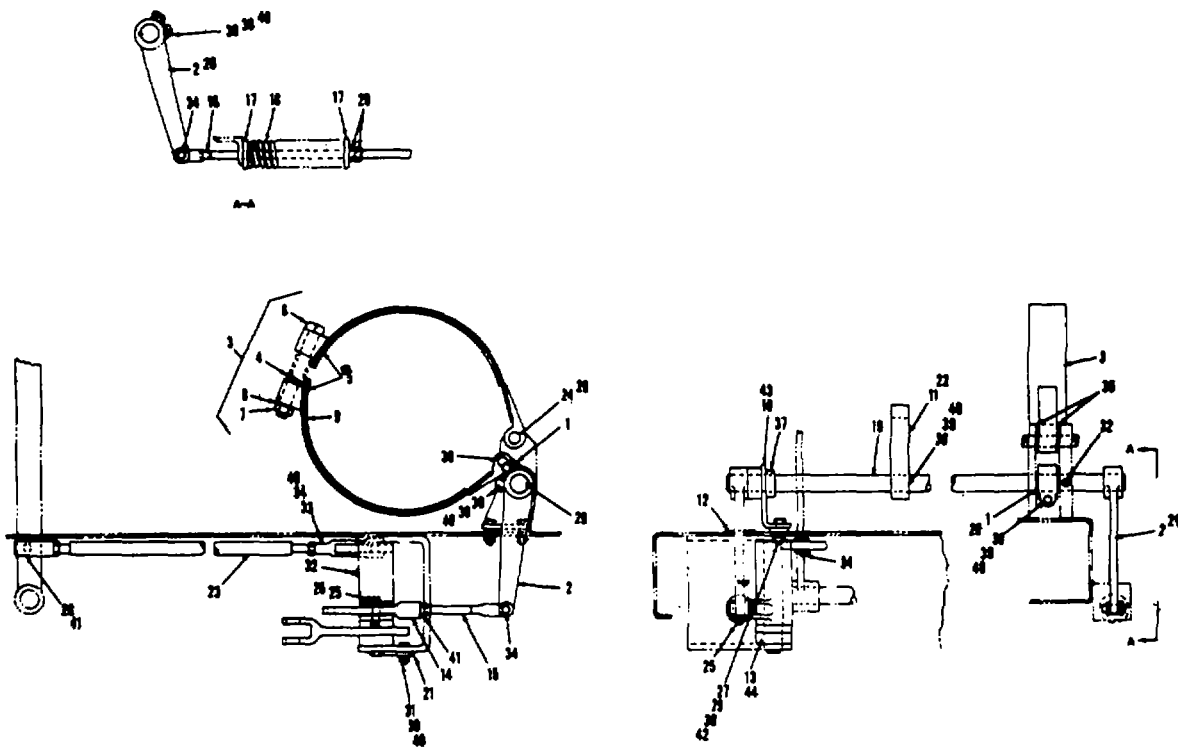

MEC 3810-227-15/120.1

1 Brake lever	12 Cover	23 Connecting rod weld.	34 Yoke pin assy
2 Brake lever	13 Bell crank	24 Pin	35 Washer, plain
3 Brake band assy	14 Shifter, yoke end	25 Pin	36 Pin
4 Spring	15 Brake release rod weld.	26 Pin	37 Collar
5 Lining	16 Brake spring rod weld.	27 Capscrew, hex hd.	38 Capscrew, hex hd
6 Bolt, sq. hd.	17 Spring seat	28 Ball joint	39 Nut, F
7 Hex nut	18 Spring	29 Nut, F	40 Washer, lock
8 Flat washer	19 Shaft	30 Washer, lock	41 Nut, F
9 Rivet #10-7	20 Key	31 Capscrew, hex hd	42 Washer, plain
10 Bearing bracket	21 Shaft weld.	32 Fitting, lube	43 Bushing
11 Interlock lever	22 Key	33 Clevis, rod end	44 Bushing

Figure 121. Boom hoist brake assembly.

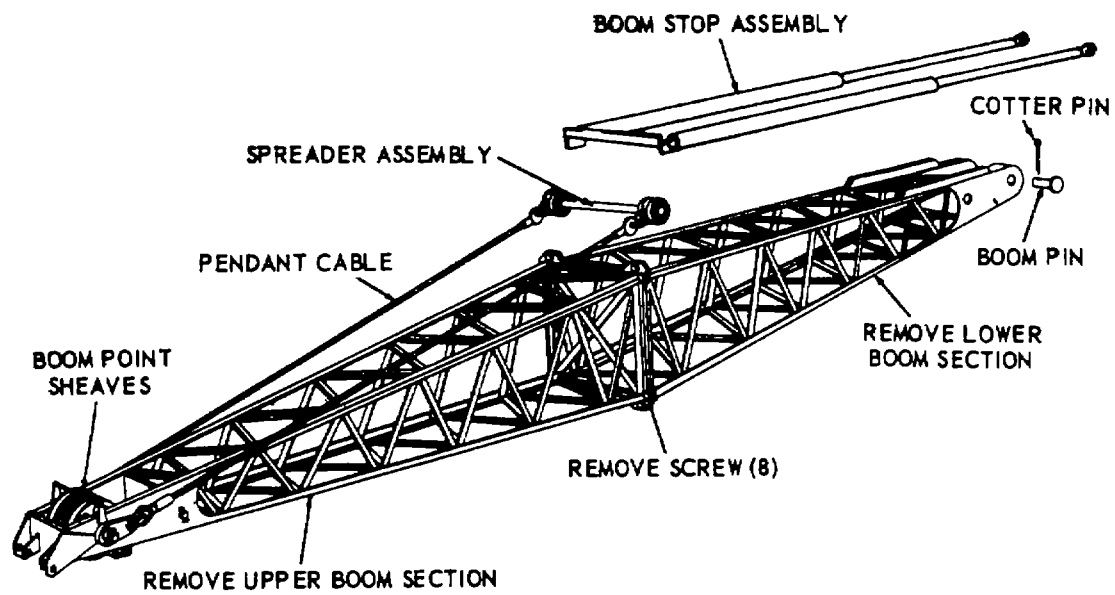

A - Crane boom

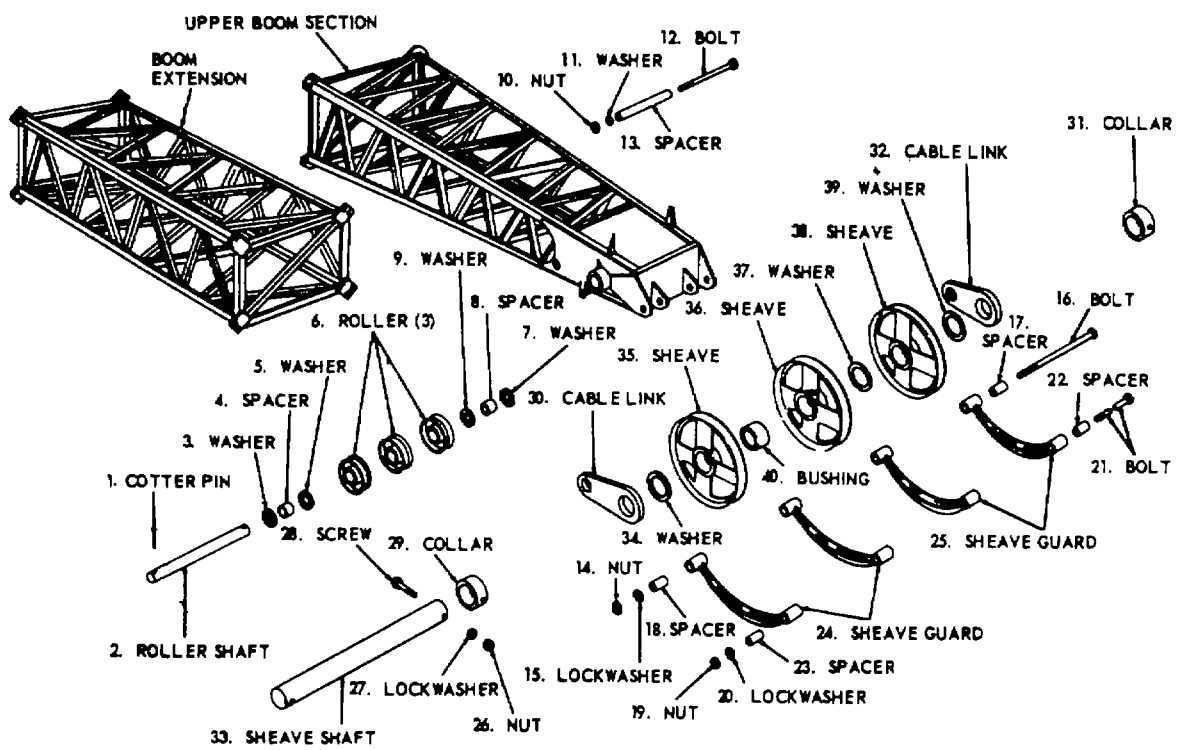

B - Crane boom, exploded view

MEC 3810-227-15/121

Figure 122. Crane boom, disassembly and reassembly.

AGO 6819A

b. *Disassembly.* Disassemble the crane boom as instructed on figure 122.

c. *Cleaning, Inspection, and Repair.*

- (1) Clean all parts of the crane boom with an approved cleaning solvent.
- (2) Inspect the crane boom for broken welds, bends, and other damage. Repair or replace the crane boom as necessary.
- (3) Inspect the boom point sheaves and pulleys and all other parts for breaks, excessive wear, and other damage. Repair or replace all defective parts as necessary.

d. *Reassembly.* Reassemble the crane boom as illustrated on figure 122.

e. *Installation.*

- (1) Install the crane boom on the revolving frame.
- (2) Install the reeving on the crane boom.

## 205. Bridle Assembly

a. *Removal.* Remove the bridle assembly from the crane boom.

b. *Disassembly.* Disassemble the bridle assembly as illustrated on figure 123.

c. *Cleaning, Inspection, and Repair.*

- (1) Clean all parts with an approved cleaning solvent.
- (2) Inspect all parts for breaks, bends, excessive wear, and other damage. Repair or replace defective parts as necessary.

d. *Reassembly.* Reassemble the bridle assembly as illustrated on figure 123.

e. *Installation.* Install the bridle assembly on the crane boom.

## 206. Boom Rack

a. *Removal.* Remove the boom rack as instructed on figure 124.

b. *Cleaning, Inspection, and Repair.*

- (1) Clean all parts with an approved cleaning solvent.
- (2) Inspect all parts for breaks, bends, excessive wear, and other damage. Repair or replace all parts as necessary.

AGO 6819A

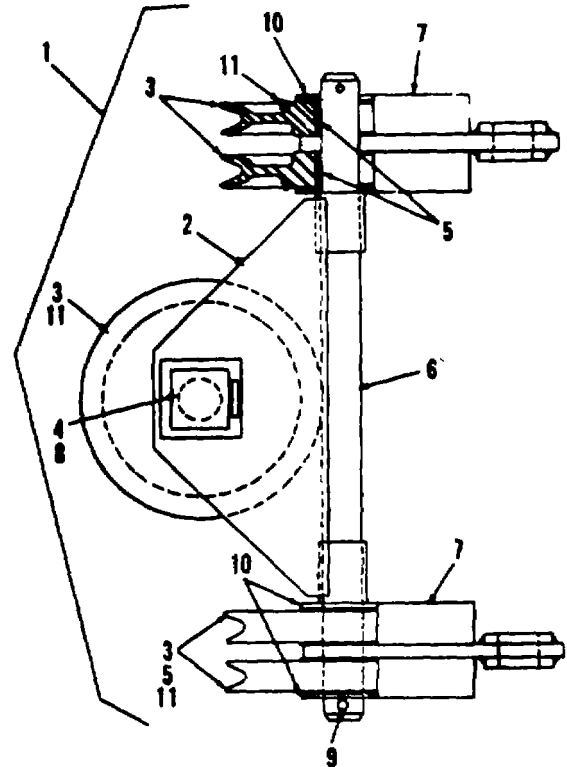

NOTE: TO DISASSEMBLE:  
REMOVE COTTER PINS (8 AND 9) AND STRIP  
SHAFT. PRESS BEARINGS (5) FROM SHEAVES.

MEC 3810-227-15/122

1	Bridle assembly	7	Bridle anchor
2	Sheave support	8	Pin, cotter
3	Sheave	9	Pin, cotter
4	Pin	10	Washer, plain
5	Bearing, sleeve	11	Fitting, lubrication
6	Shaft		

Figure 123. Bridle assembly.

c. *Installation.* Install the boom rack as illustrated on figure 124.

## 207. Boom Angle Indicator

a. *Removal and Disassembly.* Remove and disassemble the boom angle indicator in the numerical sequence as instructed on figure 125.

b. *Cleaning, inspection, and Repair.*

- (1) Clean all parts with an approved cleaning solvent.



- (2) Inspect all parts for breaks, excessive wear, and other damage. Repair or replace all defective parts as necessary.

- c. *Reassembly and Installation.* Reassemble and install the boom angle indicator in the reverse of the numerical sequence as illustrated on figure 125.

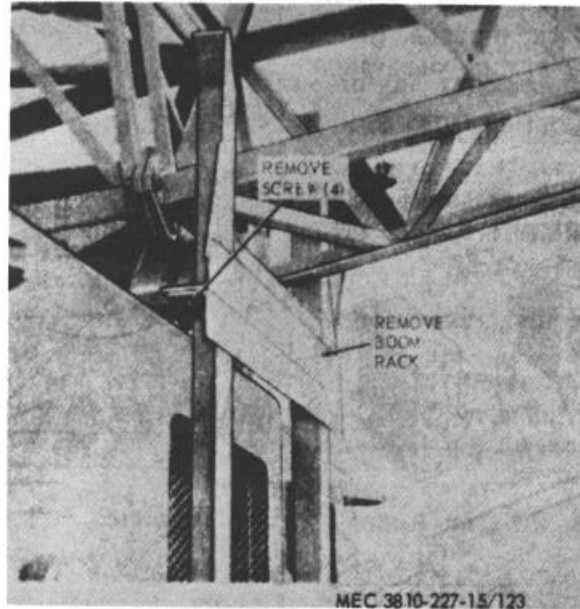

**Figure 124. Boom rack, removal and installation.**

## **Section XXII. CRANE CAB ASSEMBLY**

### **208. General**

The crane cab is located on the revolving frame and incloses the revolving frame shaft assemblies, A-frame, engine with accessories, and all levers, pedals, and linkage controls. It is constructed of sheet-steel welded panels and doors, has glass windows, and is fastened to the floor of the revolving frame with capscrews and lockwashers.

### **209. Operator's Door**

#### *a. Removal.*

- (1) Open the operator's door.
- (2) Remove the operator's door as instructed in figure 126.

#### *b. Cleaning and Inspection*

- (1) Clean the operator's door with an approved cleaning solvent.

- (2) Inspect the door for bends, broken glass, and other damage. Replace defective operator's door or glass.

- c. *Installation.* Install the operator's door as illustrated on figure 126.

### **210. Door Window and Windshield Glass**

#### *a. Removal.*

- (1) Insert the hook end of the rubber channel tool (fig. 127) in the rubber channel seal strip at the seam and slide tool around the channel to break the seal.
- (2) After seal has been broken, insert the straight end of the rubber channel tool between the rubber channel and the glass and move it slowly around the rubber channel to break the seal.
- (3) Press glass gently while breaking the seal and glass will slide out of the panel as

AGO 6819A

soon as the seal is completely broken.

- (4) To remove front window, repeat (1) through (3) above.

**b. Cleaning, Inspection, and Repair.**

- (1) Clean the edges of the window panel with an approved cleaning solvent.
- (2) Inspect the rubber channel for weather cracks and other damage. Replace defective rubber channel.
- (3) Inspect the panels for dents, bends, and other damage. Repair or replace as necessary.
- (4) Replace all cracked or broken glass.

**c. Installation.**

- (1) Start the rubber channel (fig. 127) along

the side of the window opening.

- (2) Fit the narrow edge of the rubber channel over the edge of the door panel and continue the strip around the window opening and back to the starting point with a 1/4 inch overlap.
- (3) Place the ends of the rubber channel together and press into place to obtain a tight, smooth joint.
- (4) Start the door glass in one of the lower corners of the rubber channel. Use the straight end of the rubber channel tool to lift the channel, allowing the glass panel to slip into position.
- (5) Insert the hooked end of the rubber

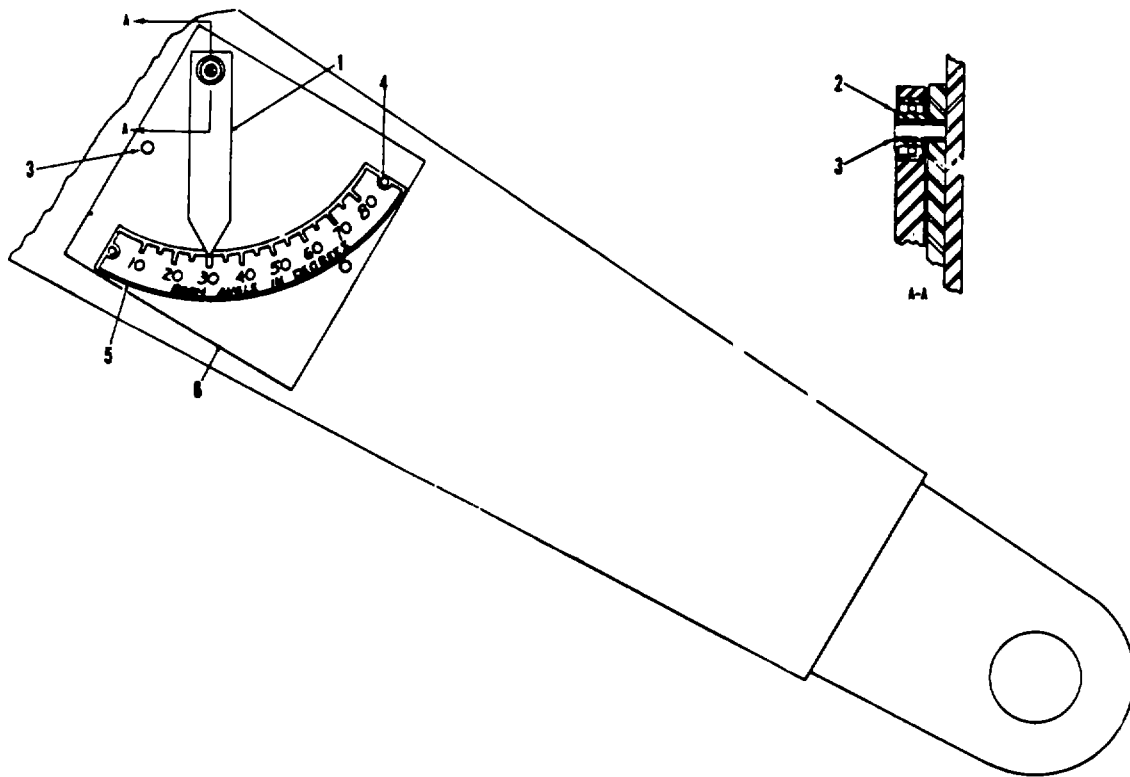

MEC 3810-227-15/124

- |                |               |                   |
|----------------|---------------|-------------------|
| 1 Indicator    | 3 Roll pin    | 5 Indicator plate |
| 2 Ball bearing | 4 Drive screw | 6 Base plate      |

**Figure 125. Boom angle indicator assembly.**

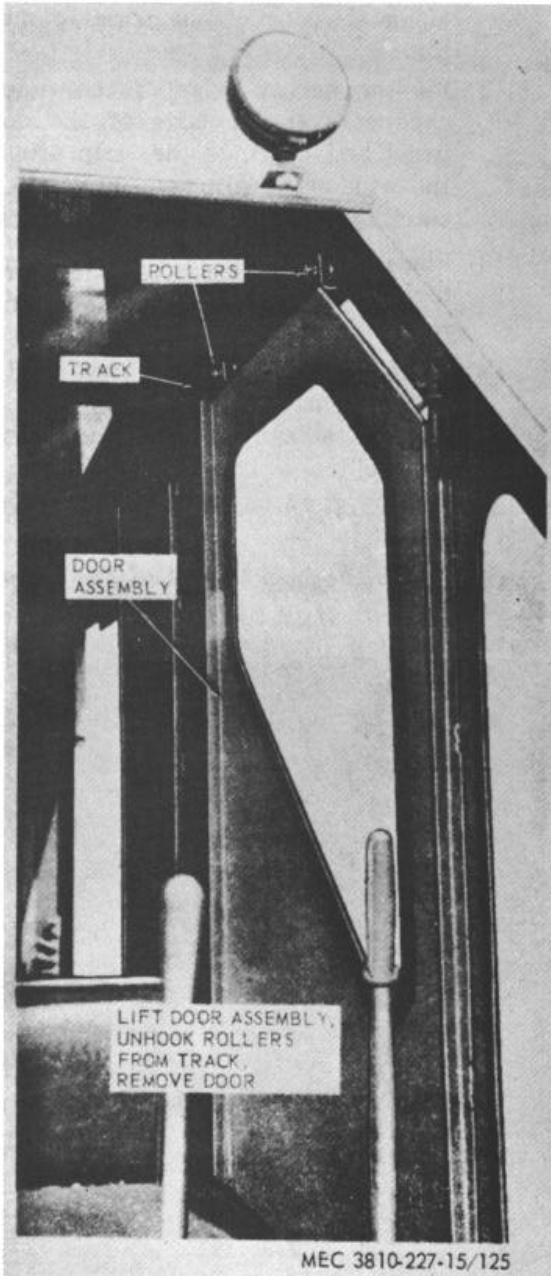

Figure 126. Operator's door, removal and installation.

channel tool in the rubber channel and force the locking strip into place.

**Note.**

Do not begin the locking operation at the strip joint. Start around the corners to avoid buckling or crimping the rubber channel.

- (6) To install front window, repeat (1) through (5) above.

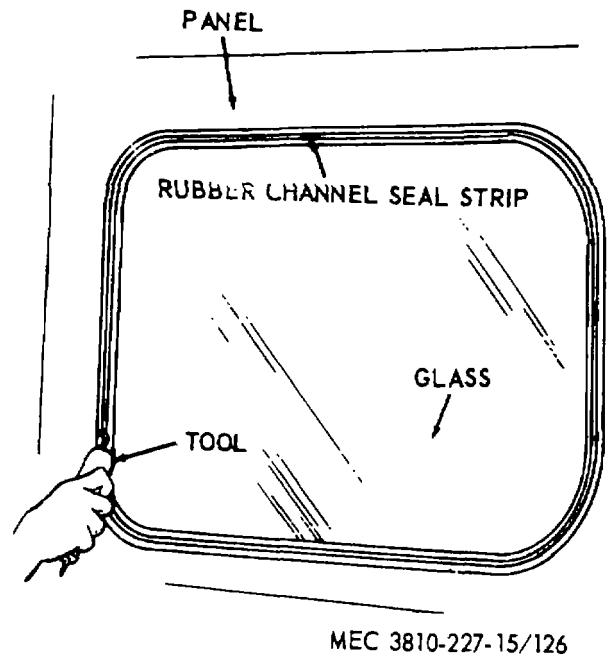

Figure 127. Door and window glass, replacement.

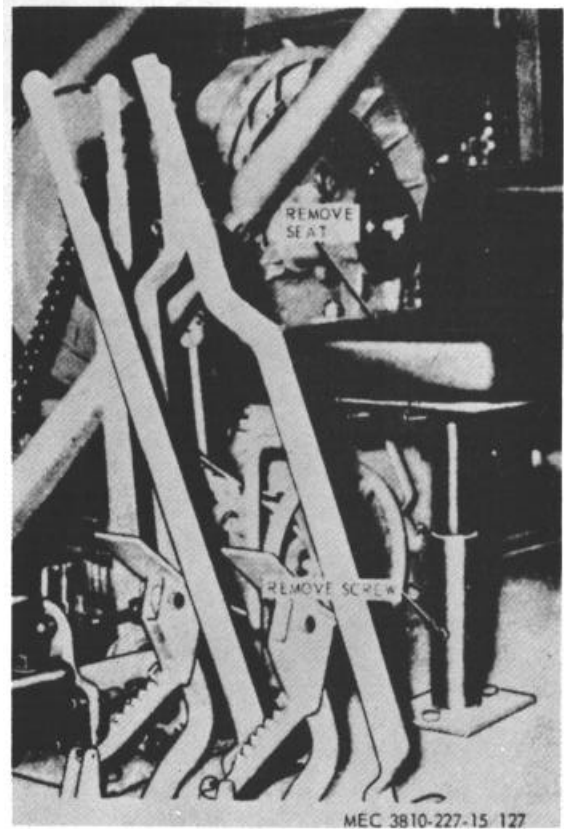

Figure 128. Operator's seat, removal and installation.

**211. Operator's Seat**

a. *Removal.* Remove the operator's seat as instructed on A, figure 128.

b. *Disassembly.* Disassemble the operator's seat as illustrated on B, figure 128.

c. *Cleaning, Inspection, and Repair.*

- (1) Clean all parts with an approved cleaning solvent.
- (2) Inspect the seat and backrest for torn,

bent, or broken conditions. Replace damaged seat or backrest.

- (3) Inspect all other parts for breaks, bends and other damage. Repair or replace as necessary.

d. *Reassembly.* Reassemble the operator's seat as illustrated on B, figure 128.

e. *Installation.* Install the operator's seat as illustrated on A, figure 128.

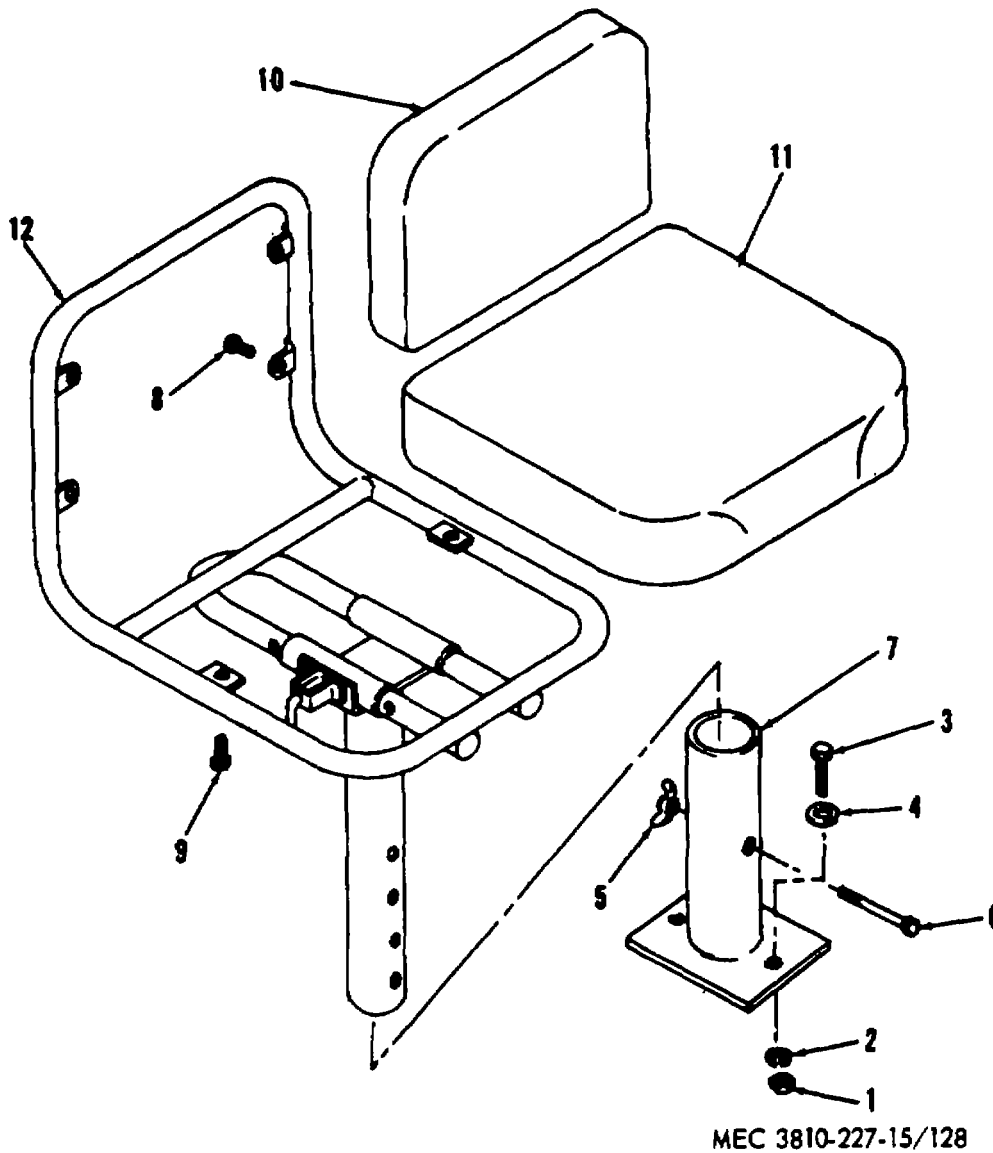

MEC 3810-227-15/128

- |                |                    |                    |               |              |            |
|----------------|--------------------|--------------------|---------------|--------------|------------|
| 1 Nut, F.      | 3 Capscrew, hex hd | 5 Nut, wing        | 7 Stand weld. | 9 Screw      | 11 Cushion |
| 2 Washer, lock | 4 Washer, plain    | 6 Capscrew, hex hd | 8 Screw       | 10 Back seat | 12 Frame   |

Figure 128. Operator's seat, exploded view.

## Section XXIII. CARRIER STEERING ASSEMBLY

### 212. General

The carrier hydropower steering gear is a cam and lever-gear design with a control valve to provide no-lag, fingertip control. It is a compact semi-integral assembly with a hydraulic cylinder installed in the linkage to apply the necessary power for steering.

### 213. Hydraulic Steering Pump

#### a. Test.

- (1) Disconnect the pressure hose from the steering valve.
- (2) Insert a pressure gage in the discharge hose. Pressure should be 700 to 900 pounds per square inch with the engine idling and wheels against stops.
- (3) Position the pressure hose on the steering valve and secure with the connector nut.

#### b. Removal.

- (1) Tag, disconnect, and drain pump lines.
- (2) Remove the hydraulic pump and drive belt (para. 149).

#### c. Cleaning and Inspection.

- (1) Clean all parts with an approved cleaning solvent.
- (2) Inspect the steering pump for breaks, leaks, and other damage. Replace defective pump.

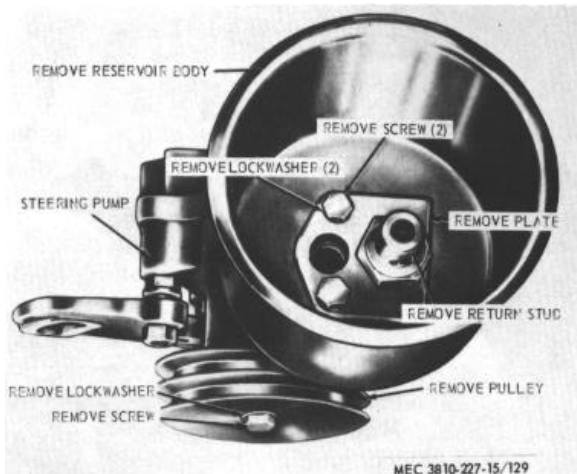

**Figure 129. Steering pump pulley and reservoir, removal and installation.**

- (3) Inspect the drive belt for breaks, fraying,

and other damage. Replace defective drive belt.

#### d. Installation.

- (1) Install the hydraulic pump and drive belt (para. 149).
- (2) Adjust drive belt. (fig. 53).
- (3) Install pump lines and replenish hydraulic oil (LO 5-3810-227-15).

### 214. Steering Pump Pulley

#### a. Removal.

- (1) Remove the steering pump drive belt (para. 145).
- (2) Remove the steering pump pulley as instructed on figure 129.

#### b. Cleaning and Inspection.

- (1) Clean the pulley with an approved cleaning solvent.
- (2) Inspect the pulley for breaks, cracks, and other damage. Replace defective pulley.

#### c. Installation.

- (1) Install the pump pulley as illustrated on figure 129.
- (2) Install the drive belt (para. 145).
- (3) Adjust the drive belt (fig. 53).

### 215. Steering Pump Reservoir

#### a. Removal.

- (1) Remove the cover and filter element from the reservoir.
- (2) Drain the reservoir.
- (3) Remove the steering pump reservoir as instructed on figure 129.

#### b. Cleaning, Inspection, and Repair.

- (1) Clean all parts with an approved cleaning solvent.
- (2) Inspect all parts for bends, cracks, and other damage. Replace or repair all defective parts.

#### c. Installation.

- (1) Install the steering pump reservoir as illustrated on figure 129.
- (2) Fill the reservoir to proper level (LO 5-3810-227-16).
- (3) Install the filter element and cover.

### 216. Steering Pump Relief Valve

a. *Removal.* Remove the steering pump relief valve as illustrated on figure 130.

AGO 6819A

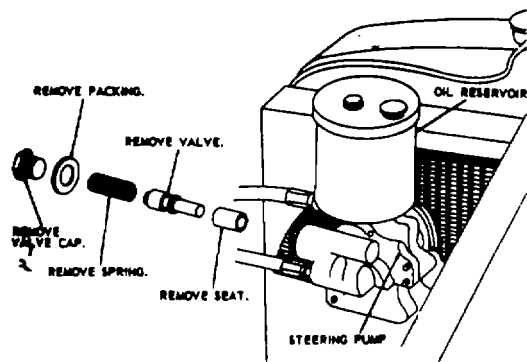

MEC 3810-227-15/130

**Figure 130. Carrier steering pump relief valve, removal and installation.**

*b. Cleaning and Inspection.*

- (1) Clean all parts of the relief valve with an approved cleaning solvent.
- (2) Inspect all parts for corrosion, breaks, excessive wear, and other damage. Replace defective parts.

*c. Installation.* Install the relief valve as illustrated on figure 130.

**217. Steering Valve**

*a. Removal.* Remove the steering valve as instructed on figure 131.

*b. Cleaning and Inspection.*

- (1) Clean all parts with an approved cleaning solvent.
- (2) Inspect the steering valve for leaks and proper operation. Replace defective valve.
- (3) Inspect the hose for frayed, cracked or broken condition. Replace defective hoses.

*c. Installation.* Install the steering valve as illustrated on figure 131.

**218. Steering Assembly Backlash Adjustment**

*a.* To adjust steering assembly backlash, loosen locknut (fig. 131) and tighten side cover adjusting screw until a very slight drag is felt when moving the steering wheel through mid-position.

*b.* Hold the adjusting screw and tighten locknut.

*c.* Check adjustment through full travel of the steering wheel.

**219. Steering Wheel**

*a. Removal.*

- (1) Remove the horn button assembly (para. 112).
- (2) Remove the steering wheel as instructed on figure 132.

*b. Cleaning and Inspection.*

- (1) Clean all parts with an approved cleaning solvent.
- (2) Inspect all parts for breaks, cracks, and other damage.

*c. Installation.*

- (1) Install the steering wheel as illustrated on figure 132.
- (2) Install the horn button assembly (para. 112).

**220. Drag Link**

*a. Removal.* Remove the drag link assembly as instructed on figure 133.

*b. Cleaning and Inspection*

- (1) Clean all parts with an approved cleaning solvent.
- (2) Inspect all parts for bends, breaks, excessive wear, and other damage. Replace defective parts as necessary.

*c. Installation.* Install the drag link assembly as illustrated on figure 133.

**221. Steering Arm**

*a. Removal.*

- (1) Remove the drag link (para. 220).
- (2) Remove the steering arm as instructed on figure 134.

*b. Cleaning and Inspection.*

- (1) Clean all parts with an approved cleaning solvent.
- (2) Inspect all parts for breaks, cracks or other damage. Replace defective parts as necessary.

*c. Installation.*

- (1) Install the steering arm as illustrated on figure 134.
- (2) Install the drag link (para. 220).

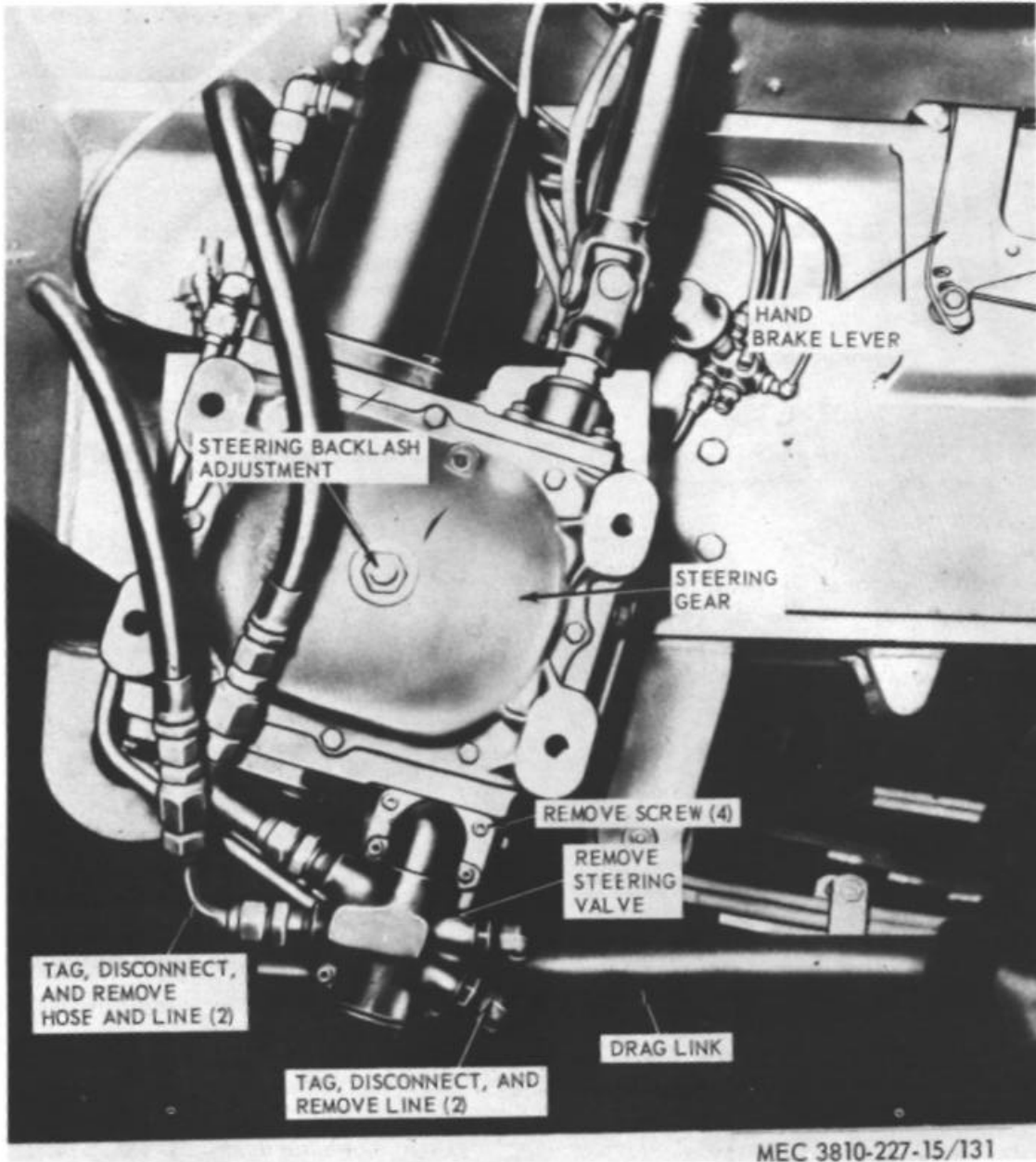

Figure 131. Carrier steering valve, removal and installation.

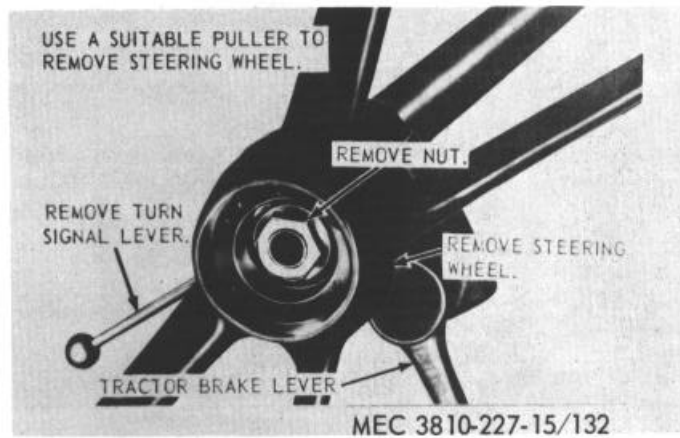

Figure 132. Steering wheel, removal and installation.

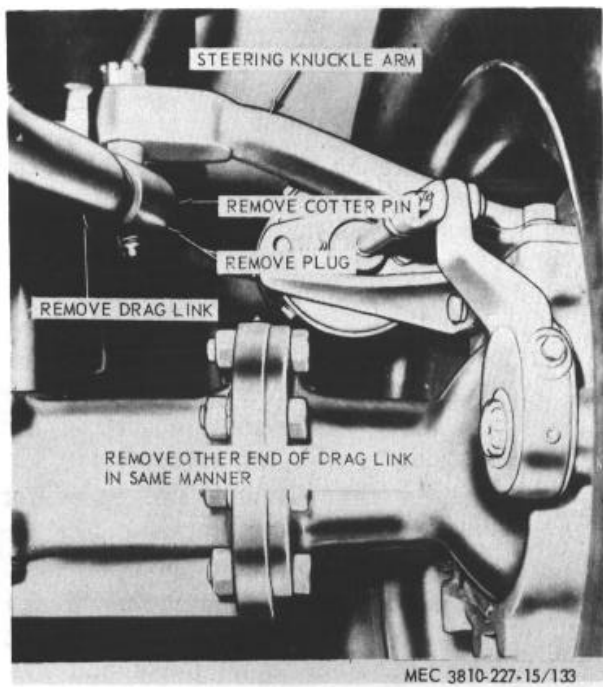

Figure 133. Drag link, removal and installation.

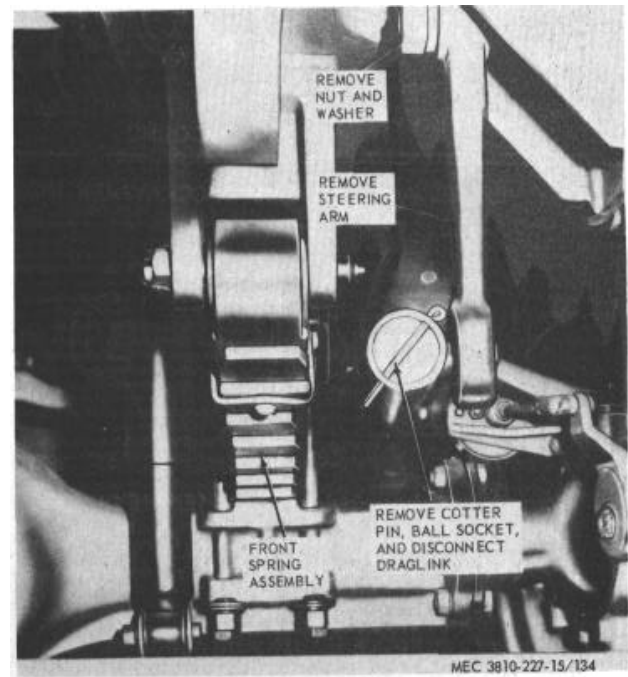

Figure 134. Steering arm, removal and installation.

## 222. Steering Tie Rod

a. *Removal.* Remove the tie rod as instructed on figure 135.

b. *Cleaning and Inspection.*

- (1) Clean all parts with an approved cleaning solvent.

- (2) Inspect the tie rod for breaks, bends, excessive wear, and other damage. Replace defective tie rod.

c. *Installation.* Install the tie rod as illustrated on figure 135.



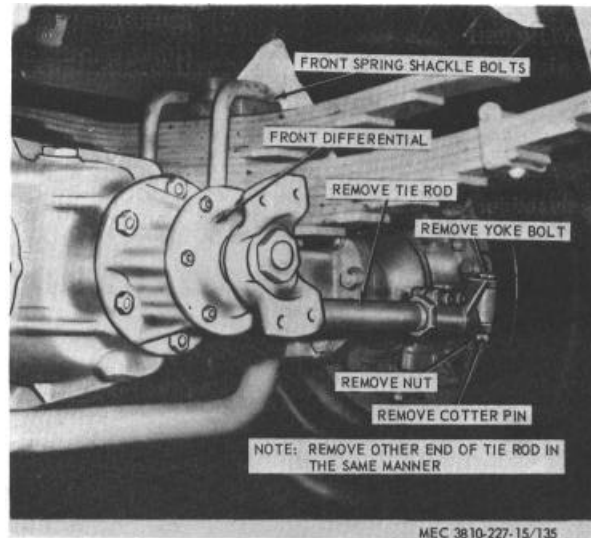

Figure 135. Steering tie rod assembly, removal and installation.

## Section XXIV. WHEELS, TIRES, AND STOCK ABSORBERS

### 223. General

The carrier is equipped with eleven 12:00 x 20, 14-ply rubber tires, eight on the rear, two on the front, and one spare. All wheels and tires on the carrier are interchangeable and can be mounted in any position on the axle. All studs and nuts are marked right or left and must be installed accordingly on the proper side of the carrier. The carrier has shock absorbers mounted on the front axle of the carrier frame.

### 224. Front Wheel

a. *Removal.* Remove the front wheel as instructed on figure 136.

b. *Cleaning, Inspection, and Repair.*

- (1) Clean the wheel assembly with an approved cleaning solvent.
- (2) Inspect the wheel assembly for bends, worn mounting holes, and other damage. Replace or repair defective wheel assemblies.

c. *Installation.* Install the front wheel as illustrated on figure 136.

### 225. Front Wheel Bearing, Hub, and Drum

a. *Removal.*

- (1) Remove the front wheel (para. 224).
- (2) Remove the front wheel hub, drum, and bearings in the numerical sequence as

instructed on figure 137.

b. *Cleaning and Inspection.*

- (1) Clean all parts with an approved cleaning solvent.
- (2) Inspect the locknut, lockring, key washer, and bearing adjusting nut for damage. Replace as necessary.
- (3) Inspect the bearings and races for damage and excessive wear (TM 9-214). Replace bearings as necessary..
- (4) Inspect all other parts for breaks, cracks, excessive heat, and, other damage. Replace all parts and gaskets as necessary.

c. *Installation.*

- (1) Pack the wheel bearings, using the prescribed lubricant ( LO 5-6810 227-15).
- (2) Install the wheel bearings, hub, and drum in the reverse of the numerical sequence as illustrated on figure 137.
- (3) Install front wheel (para. 224).

#### Note

When installing the bearing, tighten the bearing adjusting nut until the wheel locks; then back off on the adjusting nut until the wheel turns freely.

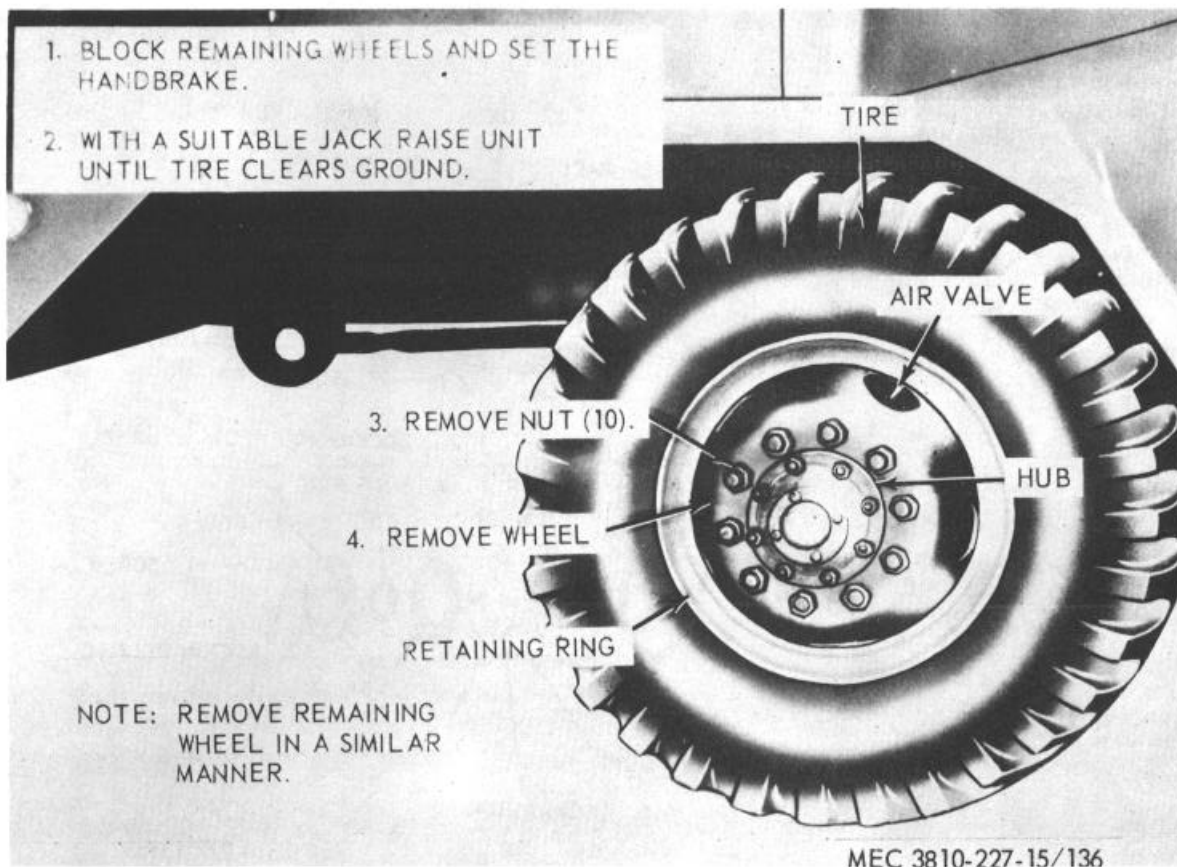

**Figure 16. Front wheel, removal and installation.**

**226. Rear Wheel**

*a. Removal.* Remove the rear wheels as instructed on figure 138.

*b. Cleaning and Inspection.*

- (1) Clean the rear wheels with an approved cleaning solvent.
- (2) Inspect the rear wheels for bent condition and other damage. Replace rear wheels as necessary.

*c. Installation.* Install the rear wheels as illustrated on figure 138.

**227. Rear Wheel Borings, Drum, Hub, and Axle Shaft**

*a. Removal.*

- (1) Remove the rear wheel (para. 226).

- (2) Remove the axle shaft, wheel bearings, drum, and hub in the numerical sequence as instructed on figure 139.

*b. Cleaning and Inspection.*

- (1) Clean all parts with an approved cleaning solvent.
- (2) Inspect the wheel bearings and races for excessive wear and other damage (TM 9-214).
- (3) Inspect all other parts for breaks, excessive wear, and other damage. Replace all defective parts as necessary.

*c. Installation.*

- (1) Pack the bearings using the prescribed lubricant (LO 5-3810-227-15).

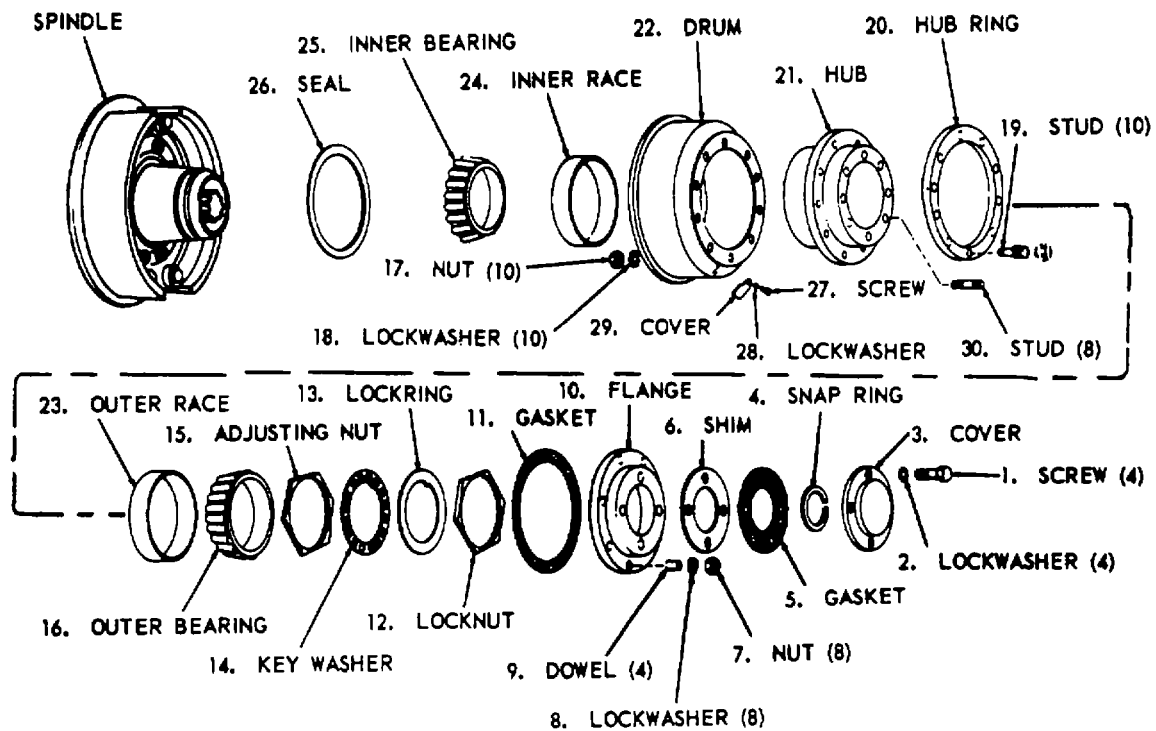

MEC 3810-227-15/137

Figure 137. Front wheel bearings, hub, drum, exploded view.

- (2) Install the wheel bearings, hub, drum, and axle shaft in the reverse of the numerical sequence as illustrated on figure 139.

**Note**

When installing the bearings, tighten the bearing adjusting nut until the wheel locks; then back off on the adjusting nut until the wheel turns freely.

- (3) Install the rear wheel (para. 226).

**228. Tires and Tubes**

*a. Removal.*

- (1) Remove the wheel from the carrier (para. 224 and/or 226).
- (2) Deflate tire by removing valve core. Insert pry bar in slot of retaining ring near split. Pry end of ring out over edge of rim,

and remove ring from rim.

**Caution**

**Do not attempt to remove tire retaining ring until tire is completely deflated.**

- (3) Remove the tire from the rim and remove the tube liner and tube from the tire.
- b. Cleaning, Inspection, and Repair.*
- (1) Clean the rim with an approved cleaning solvent.
  - (2) Inspect the tire for breaks, cuts, excessive wear, and other damage. Repair or replace tire as necessary.
  - (3) Inspect the tube and liner for cuts, punctures, and other damage. Repair or replace tube and liner as necessary.
  - (4) Inspect the retaining ring for bends and other damage. Replace defective retaining ring.
- c. Installation.*
- (1) Install the tube in the tire so the valve stem is in line with the balancing mark on the tire.

- (5) Install the wheel on the carrier (para. 244 and/or 226).

## 229. Front Shock Absorbers

### a. Removal.

- (1) Remove the shock absorber as instructed on figure 140.
- (2) Inspect the shock absorber for proper operation and other damage. Replace defective shock absorber.
- (3) Inspect the mounting hardware for breaks, excessive wear, and other damage. Replace defective hardware.

### b. Installation.

- (1) Install the right-front shock absorber as illustrated on figure 140.
- (2) Install the left-front shock absorber in a similar manner.

## 230. Ventilation Breathers

### a. Removal.

- (1) Remove the front differential breather as instructed on figure 140.
- (2) Remove rear differential breathers in a similar manner.
- (3) Remove the transfer case breather in a similar manner.

### b. Cleaning and Inspection.

- (1) Clean the breathers with an approved cleaning solvent.
- (2) Inspect the breathers for bends, breaks, and other damage. Replace defective breathers as necessary.

### c. Installation.

- (1) Install the front differential breather as illustrated on figure 140.
- (2) Install the remaining breathers in a similar manner.

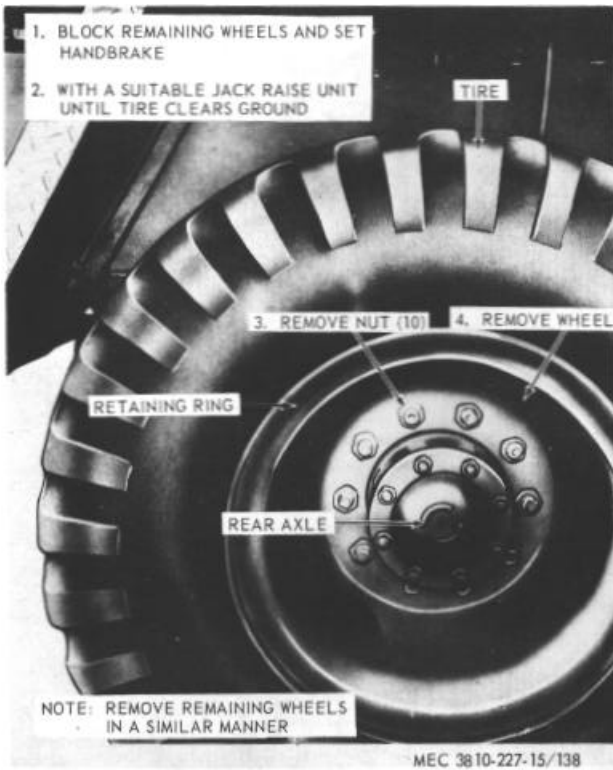
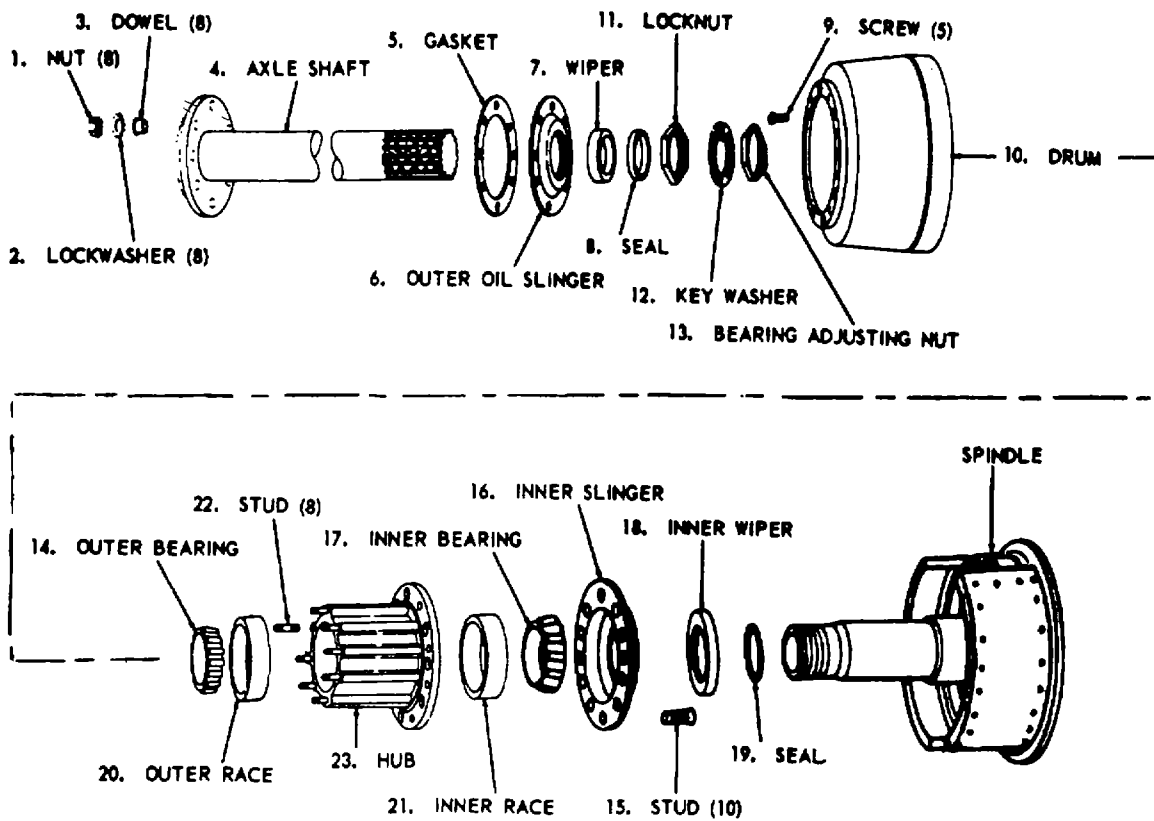

**Figure 138. Rear wheel, removal and installation.**

- (2) Install the liner in the tire and inflate tube slightly to prevent the liner from falling out and the tube from being pinched.
- (3) Install the tire on the rim and secure with the retaining ring.
- (4) Inflate the tire to 75 psi.

### **Caution**

**Lay tire with the retaining ring down and secure the wheel with a chain to a beam or other solid object while inflating tire to avoid injury.**



MEC 3810-227-15/139

Figure 139. Gear wheels bearings, axle, drum, and hub, exploded view.

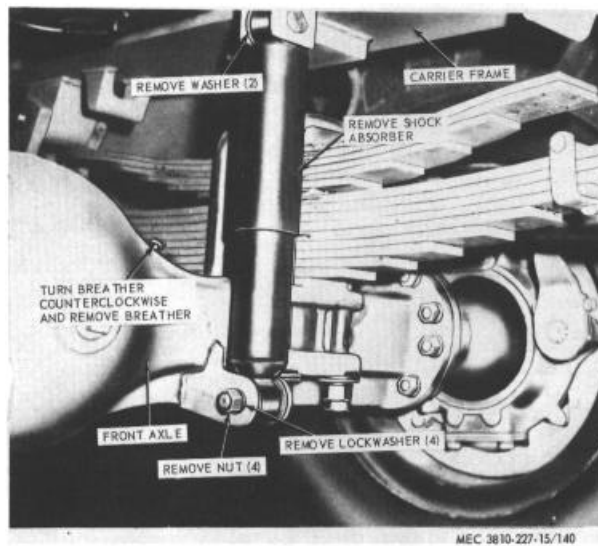

Figure 140. Right-front shock absorber and different breather, removal and installation.

## Section XXV. CARRIER AIRBRAKE SYSTEM

### 231. General

The carrier is equipped with service brakes on all six wheels, controlled by the airbrake system. In this airbrake system, the brakes are set by the power of

compressed air and set faster and more effectively than manual footbrakes. The air system consists of an air compressor, valves, reservoirs, brake chamber, and connecting hoses, tubes, and fittings. The air

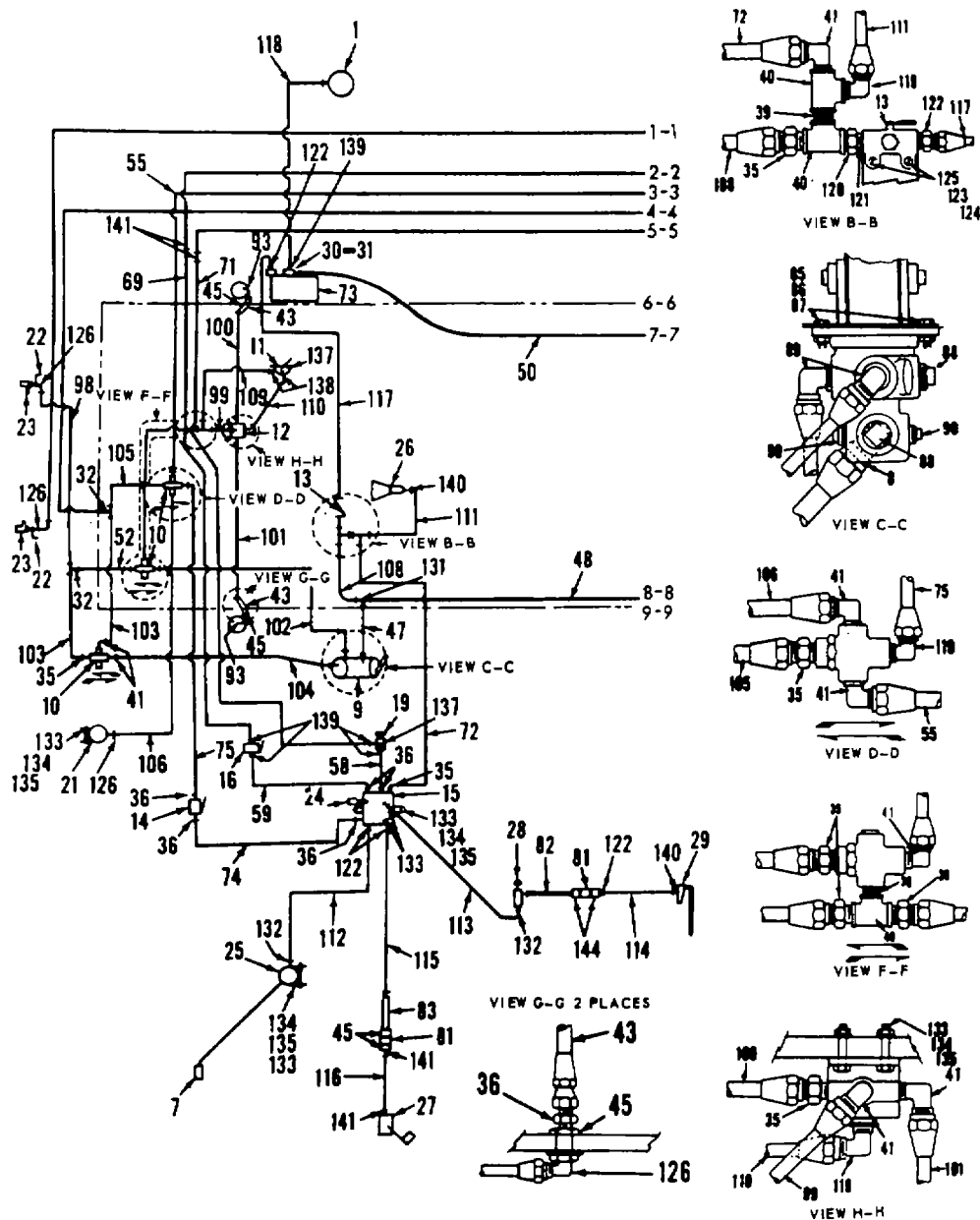

MEC 3810-227-15/141 ①

Figure 141. Carrier airbrake system, piping diagram.

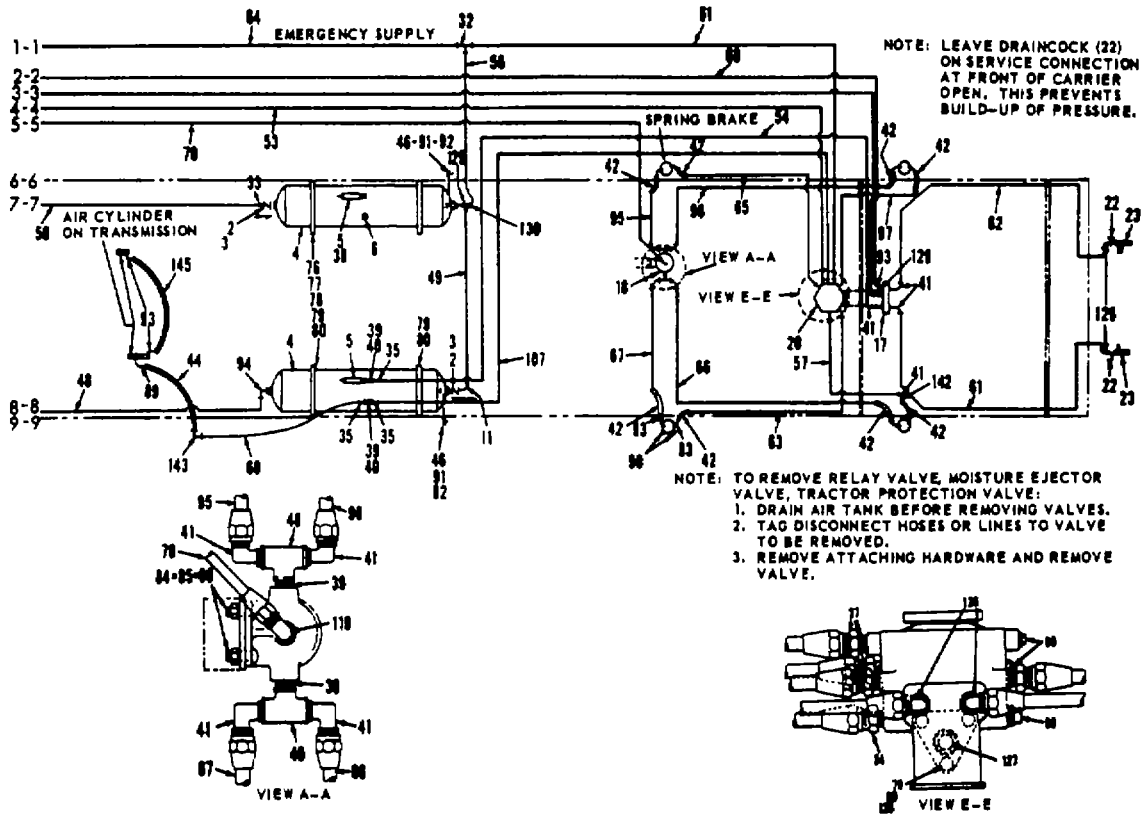

MEC 3810-227-15/141 ②

- |                                   |                          |
|-----------------------------------|--------------------------|
| 1 Alcohol evaporator              | 29 Wiper                 |
| 2 Single check valve              | 30 Discharge fitting     |
| 3 Bushing, pipe                   | 31 Discharge gasket      |
| 4 Reservoir                       | 32 Tee, tube             |
| 5 Safety valve                    | 33 Union, tube half      |
| 6 Plug, pipe                      | 34 Union, tube half      |
| 7 Buzzer                          | 35 Union, tube half      |
| 8 Elbow, tube                     | 36 Union, tube half      |
| 9 Treadle-valve                   | 37 Union, tube half      |
| 10 Double check valve             | 38 Street elbow          |
| 11 Two way control valve          | 39 Close nipple          |
| 12 Limiting & quick release valve | 40 Pipe Tee, brass       |
| 13 Air supply valve               | 41 Elbow, tube           |
| 14 Hand control valve             | 42 Hose Assy. 350"       |
| 15 Manifold                       | 43 Hose Assy. 240"       |
| 16 Tractor protective valve       | 44 Hose Assy. 180"       |
| 17 Tractor protection valve       | 45 Anchor coupling       |
| 18 Quick release valve            | 46 Drain cock            |
| 19 Push pull control valve        | 47 Tubing Assy. 119"     |
| 20 Relay emergency valve          | 48 Tubing Assy. 119"     |
| 21 Stop light switch              | 49 Tubing Assy. 19"      |
| 22 Shut off valve                 | 50 Tubing Assy. 98"      |
| 23 Hose coupling                  | 51 Tubing Assy. 84 1/4"  |
| 24 Pressure transmitter           | 52 Tubing Assy. 12"      |
| 25 Indicator switch               | 53 Tubing Assy. 284"     |
| 26 Air horn                       | 54 Tubing Assy. 160 1/2" |
| 27 Wig Wag                        | 55 Tubing Assy. 272"     |
| 28 Wiper regulator valve          | 56 Tubing Assy. 10"      |

Figure 141. - Continued.

57	Tubing Assy. 40"	104	Tubing Assy. 231-13/16"
58	Tubing Assy. 56"	105	Tubing Assy. 12"
59	Tubing Assy. 84"	106	Tubing Assy. 20 1/4"
60	Tubing Assy. 26"	107	Tubing Assy. 141 3/4"
61	Tubing Assy. 49"	108	Tubing Assy. 15 1/2"
62	Tubing Assy. 49"	109	Tubing Assy. 67 5/8"
63	Tubing Assy. 69 7/8"	110	Tubing Assy. 60 1/2"
64	Tubing Assy. 186"	111	Tubing Assy. 74"
65	Tubing Assy. 69 7/8"	112	Tubing Assy. 23 1/2" "
66	Tubing Assy. 78"	113	Tubing Assy. 70"
67	Tubing Assy. 32"	114	Tubing Assy. 59 1/4"
68	Tubing Assy. 174"	115	Tubing Assy. 60"
69	Tubing Assy. 113"	116	Tubing Assy. 46 1/2"
70	Tubing Assy. 131"	117	Tubing Assy. 76 5/8"
71	Tubing Assy. 90"	118	Tubing, Copper, 1/8" O.D. x 60
72	Tubing Assy. 28 1/2"	119	Elbow, tube
73	Air compressor	120	Bushing
74	Tubing, copper, 58"	121	Nipple, close
75	Tubing, copper, 83"	122	Union, tube half
76	Bracket-air tank	123	Screw
77	Capscrew	124	Washer, lock
78	Capscrew	125	Nut
79	Lockwasher	126	Elbow, tube
80	Nut	127	Plug
81	Quick disconnect coupling	128	Capscrew
82	Hose Assy. (Wiper)	129	Flare to Male Run Tee
83	Hose Assy. (Wig-Wag)	130	Female to Male Flare Conn.
84	Screw	131	Union, Tee
85	Washer, lock	132	Elbow, tube
86	Nut, F	133	Capscrew
87	Capscrew	134	Nut
88	Plug	135	Washer, lock
89	Elbow, tube	136	Elbow, pipe, street
90	Plug	137	Plug
91	Elbow	138	Elbow, tube
92	Nipple	139	Connector
93	Elbow, tube	140	Elbow, tube
94	Elbow, tube	141	Union, tube
95	Tubing Assy. 24"	142	Connector, tube
96	Tubing Assy. 78"	143	Elbow, tube
97	Tubing Assy. 40"	144	Coupling
98	Tubing Assy. 28 3/4"	146	Hose Assy.
99	Tubing Assy. 4 1/4"	146	Strap, cable (Not Illustrated)
100	Tubing Assy. 82"	147	Strap, cable (Not Illustrated)
101	Tubing Assy. 49 1/2"	148	Strap, Cable (Not Illustrated)
102	Tubing Assy. 28 1/4"	149	Washer, lock (Not Illustrated)
103	Tubing Assy. 4"	150	Nut (Not Illustrated)

**Figure 141. - Continued.**

compressor furnishes the compressed air needed to operate the brakes. The compressor is a two-cylinder, engine-lubricated, watercooled, single-acting, reciprocating type located on the right-front side of the engine, and driven by a V-belt from the engine crankshaft.

### **232. Air Lines, Hoses, and Fittings**

#### *a. Removal*

- (1) Remove the screws and clamps securing airhoses and lines to carrier frame.
- (2) Disconnect the air hoses and lines from the valves, brake chambers, and air compressor; remove lines and hoses. Refer to the carrier airbrake system piping diagram (fig. 141).

#### *b. Cleaning and Inspection.*

- (1) Clean all lines and hoses with an approved cleaning solvent.
- (2) Inspect the lines for dents, breaks and wear.
- (3) Inspect the airhoses for cracks, breaks, and deterioration.
- (4) Inspect the line and hose fittings for damaged threads. Replace all defective lines, hoses, and fittings as necessary.

#### *c. Installation.*

- (1) Install and connect lines and airhoses to the compressor, valves, and brake chambers.



- (2) Secure the lines and airhoses to the carrier frame with the clamps and screws.

### 233. Air Pressure Gage

a. *Removal.* Remove the air pressure gage as instructed on figure 57.

b. *Cleaning and Inspection.*

- (1) Clean all parts with an approved cleaning solvent.
- (2) Inspect the air pressure gage for cracked or broken glass. Replace as necessary.
- (3) Inspect the air pressure gage for proper operation. Replace an inoperative air pressure gage.
- (4) Inspect all mounting hardware for stripped or damaged threads. Replace as necessary.

c. *Installation.* Install the air pressure gage as illustrated on figure 67.

### 234. Front and Rear Brake Chambers

a. *Removal.*

- (1) Disconnect the brake chamber rod from slack adjuster (para 241).

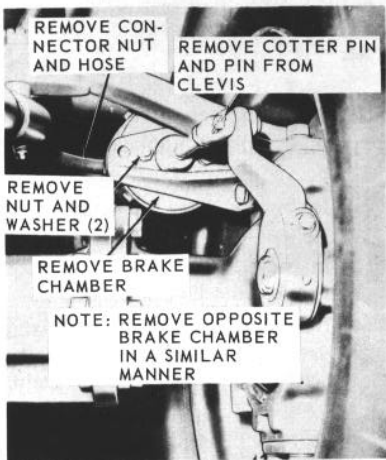

A – Front Brake Chamber, Installed View.

- (2) Remove the front and rear brake chambers as instructed on figure 142.

b. *Cleaning and Inspection.*

- (1) Clean all parts with an approved cleaning solvent.
- (2) Inspect the brake chamber for proper working condition. Replace a defective brake chamber as necessary.
- (3) Inspect brake chamber and hose for cracks, holes, and deterioration of hose.
- (4) Replace all defective parts as necessary.

c. *Installation.*

- (1) Install the front and rear brake chambers as illustrated on figure 142.
- (2) Connect the brake chamber rod to the slack adjuster (para. 241).

### 235. Quick Release Valve

a. *Removal.* Remove the quick release valve as instructed on figure 148.

b. *Cleaning and Installation.*

- (1) Clean the quick release valve with an approved leaning solvent.

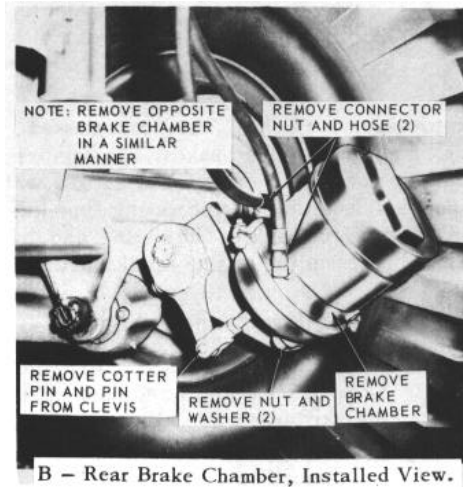

B – Rear Brake Chamber, Installed View.

Figure 142. Front and rear break chambers, removal and installation.

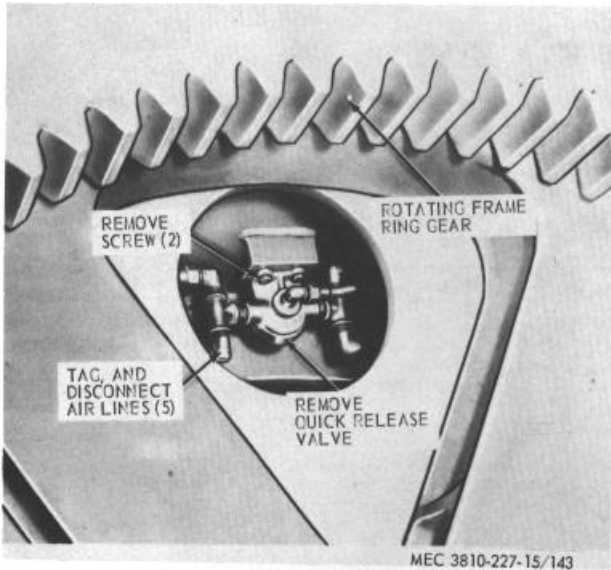

**Figure 143. Quick release valve, removal and installation.**

- (2) Inspect the quick release valve for breaks, damaged threads, proper operation, and other damage. Replace defective quick release valve and mounting hardware.

*c. Installation.* Install the quick release valve as illustrated on figure 143.

### **236. Tractor Protection Valve**

*a. Removal.* Remove the tractor protection valve as instructed on figure 141.

*b. Cleaning and Inspection.*

- (1) Clean the protection valve with an approved cleaning solvent.
- (2) Inspect the protection valve for damaged thread holes and proper operation. Replace a damaged or defective protection valve as necessary.
- (3) Inspect all mounting hardware for stripped or damaged threads.
- (4) Replace all defective parts as necessary.

*c. Installation.* Install the tractor protection valve as illustrated on figure 141.

### **237. Moisture Ejector Valve**

*a. Removal.* Remove the moisture ejector valve

as instructed on figure 141.

*b. Cleaning and Installation.*

- (1) Clean the moisture ejector valve with an approved cleaning solvent and dry thoroughly.
- (2) Inspect the moisture ejector valve for proper operation. Replace a defective moisture valve as necessary.
- (3) Inspect all fittings and mounting hardware for stripped or damaged threads. Replace all parts as necessary.

*c. Installation.* Install the moisture ejector valve as illustrated on figure 141.

### **238. Relay Valve**

*a. Removal.* Remove the relay valve as instructed on figure 141.

*b. Cleaning and Inspection.*

- (1) Clean the relay valve with an approved cleaning solvent.
- (2) Inspect the relay valve for proper operation. Replace a defective relay valve as necessary.
- (3) Inspect all fittings and mounting hardware for stripped or damaged threads. Replace all parts as necessary.

*c. Installation.* Install the relay valve as illustrated on figure 141.

### **239. Wet and Dry Air Tank**

*a. Removal.* Remove the wet and dry air tanks as instructed on figure 144.

*b. Cleaning and Inspection.*

- (1) Clean all parts with an approved cleaning solvent.
- (2) Inspect the wet and dry tanks for cracks, holes, or other damage. Replace a defective wet or dry tank.
- (3) Inspect all fittings and mounting hardware for stripped or damaged threads. Replace as necessary.
- (4) Inspect all hoses for cracks, breaks, and deterioration. Replace all defective hoses as necessary.

*c. Installation.* Install the wet and dry air tanks as illustrated on figure 144.

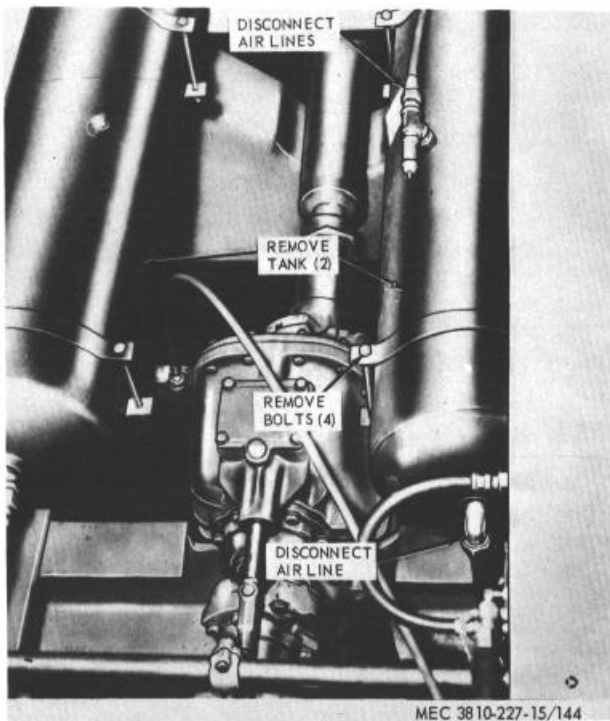

**Figure 144. Wet and dry air tank, removal and installation.**

#### 240. Air Emergency and Service Shutoff Valves

*a. Removal.* Remove the air emergency and service shutoff valves as instructed on figure 145.

*b. Cleaning and Inspection.*

- (1) Clean all parts with an approved cleaning solvent.
- (2) Inspect the air emergency and service valves for proper operation. Replace defective valves as necessary.
- (3) Inspect all nipples and mounting hardware for stripped or damaged threads. Replace all defective parts as necessary.
- (4) Inspect the coupling for breaks and other damage. Replace coupling and defective parts.

*c. Installation.* Install the air emergency and service shutoff valves as illustrated on figure 145.

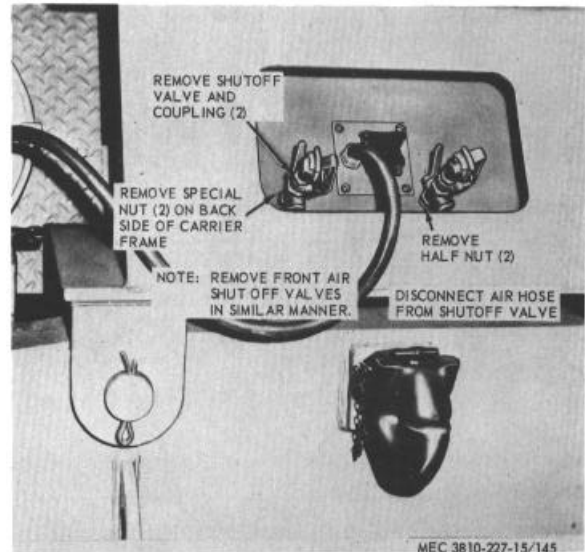

**Figure 145. Rear air shutoff valves and air manifold, removal and installation.**

#### 241. Front Brakeshoes

*a. Brakeshoe Removal.*

- (1) Remove the wheel and drum from brakeshoe assembly (para. 224).
- (2) Remove the front brakeshoes as instructed on figure 146.

*b. Slack Adjuster Removal.* Remove the slack adjuster as instructed on figure 147.

*c. Cleaning and Inspection.*

- (1) Clean all parts with an approved cleaning solvent except the brake lining and dry thoroughly.
- (2) Inspect the brake lining for excessive wear and glazing. Remove glazing by brushing with a wire brush.
- (3) Inspect the brakeshoes for cracks, breaks, and excessive pinhole wear. Replace damaged brakeshoes as necessary.
- (4) Inspect the springs for broken or weak tension and inspect all pins for wear. Replace all mounting hardware as necessary.
- (5) Inspect the slack adjuster for breaks, excessive wear, and other damage. Replace defective slack adjusters.

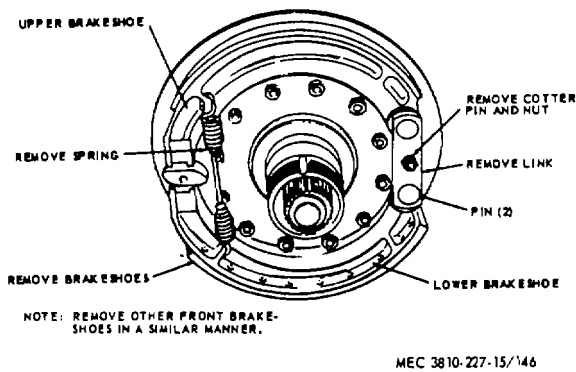

**Figure 146. Front brakeshoe, removal and installation.**

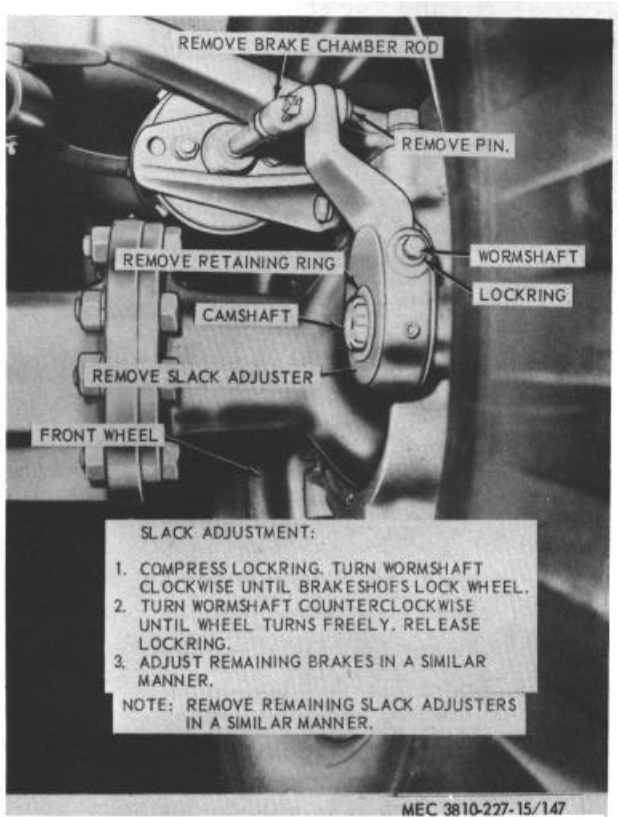
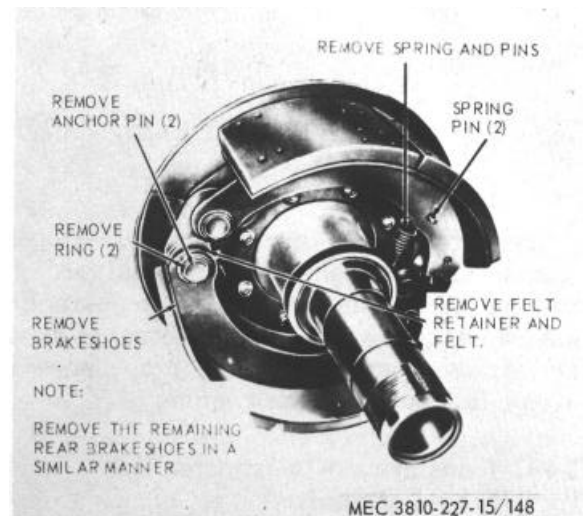

**Figure 147. Slack adjuster removal, installation, and adjustment.**

*d. Installation.*

- (1) Install the brakeshoes as illustrated as figure 146.
- (2) Install the drum and wheel (para. 224).

- (3) Install the slack adjusters as illustrated on figure 147.



**Figure 148. Rear brakeshoe, removal and installation.**

- e. Brake Adjustment.* Adjust the brakes as instructed on figure 147.

**242. Rear Brakeshoes**

*a. Removal.*

- (1) Remove the wheel and drum from brake assembly (para. 226).
- (2) Remove the rear brakeshoes as instructed on figure 148.

*b. Cleaning and Inspection.*

- (1) Clean all parts with an approved - cleaning solvent except the brake lining, and dry thoroughly.
- (2) Inspect the brake lining for excessive wear and glazing. Remove the glazing by brushing with a wire brush.
- (3) Inspect the brakeshoes for cracks, breaks, and excessive pinhole wear. Replace damaged brakeshoes as necessary.
- (4) Inspect the spring for tension and inspect all pins for wear. Replace all mounting hardware as necessary.

*c. Installation.*

- (1) Install the rear brakeshoes as illustrated on figure 148.

- (2) Install the drum and wheel (para. 226).

*d. Adjustment.* Adjust the rear brakeshoes in a similar manner as for front brakeshoes (para. 241).

## Section XXVI. PROPELLER SHAFTS AND CONTROLS

### 243. General

The carrier is equipped with four propeller shafts. Each propeller shaft is equipped with two universal joints and one slip joint. Each has two flanged yokes for connecting to driving and driven components. The propeller shafts are of tubular-type construction.

### 244. Transmission-To-Transfer Case Prop Her Shaft

#### *a. Removal.*

- (1) Remove the transmission-to-transfer case propeller shaft in the numerical sequences as instructed on figure 149.
- (2) Remove the rear axle, the tandem, and the front axle propeller shafts in a similar manner.

#### *b. Cleaning, Inspection, and Repair.*

- (1) Clean all parts with an approved cleaning solvent.
- (2) Inspect the spider bearings for excessive wear and other damage. Replace spider bearings as necessary.

#### *c. Installation.*

- (1) Install the transmission-to-transfer case propeller shaft in the reverse of the numerical sequence as illustrated on figure 149.

- (2) Install the front axle the tandem, and the rear axle propeller shaft in a similar manner.

### 245. Transmission Control Rod

*a. Removal and Disassembly.* Remove and disassemble the transmission control rod as illustrated on figure 160.

#### *b. Cleaning, Inspection, and Repair.*

- (1) Clean all parts with an approved cleaning solvent.
- (2) Inspect all parts for excessive wear, bends, breaks, and other damage. Replace or repair all defective parts as necessary.

*c. Reassembly and Installation.* Reassemble and install the control rod assembly as illustrated on figure 150.

### 246. Transfer Case Shifter Levers and Controls

*a. Removal.* Remove the shifter levers and controls as instructed on figure 151.

#### *b. Cleaning, Inspection, and Repair.*

- (1) Clean all parts with an approved cleaning solvent.
- (2) Inspect-all parts for breaks, bends, and other damage. Repair or replace all parts as necessary.

*c. Installation.* Install the shifter levers and controls as illustrated on figure 151.

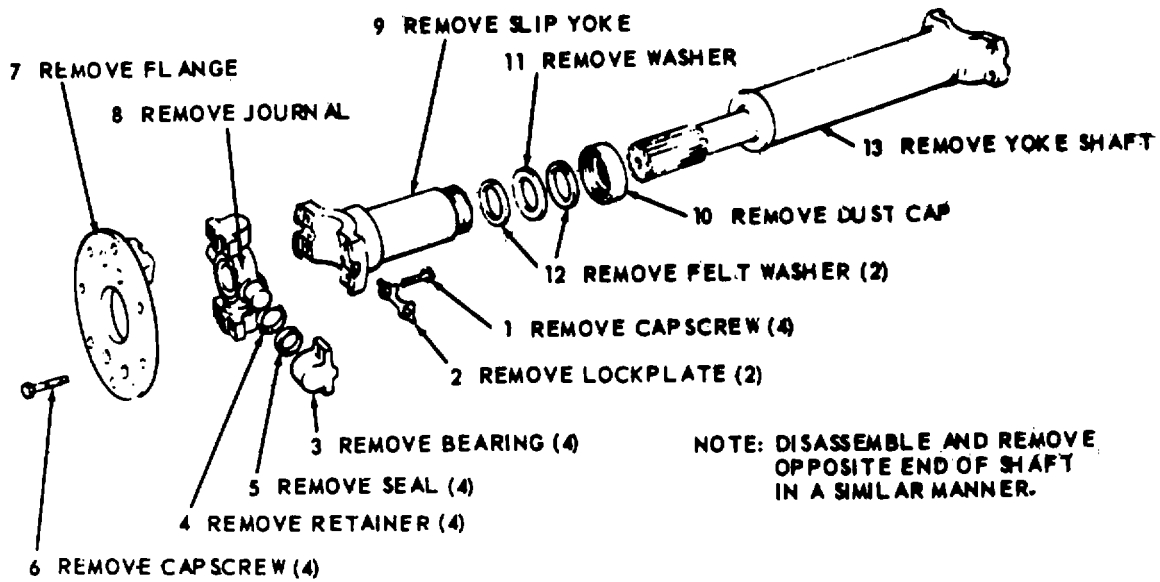

MEC 3810-227-15/149

Figure 149. Propeller shaft and universal joint, removal disassembly, exploded view.

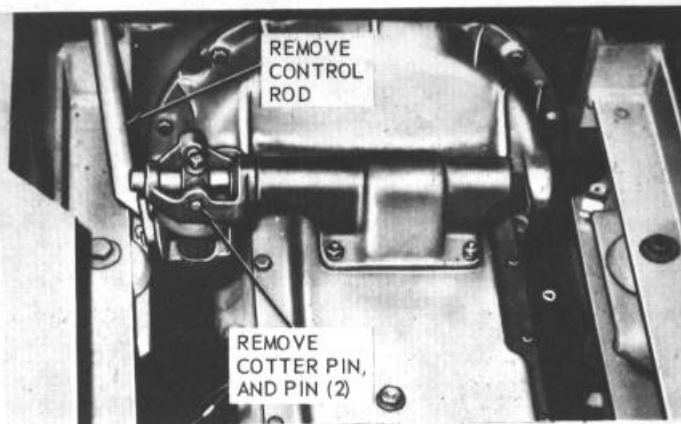

A - Control Rod Removal.

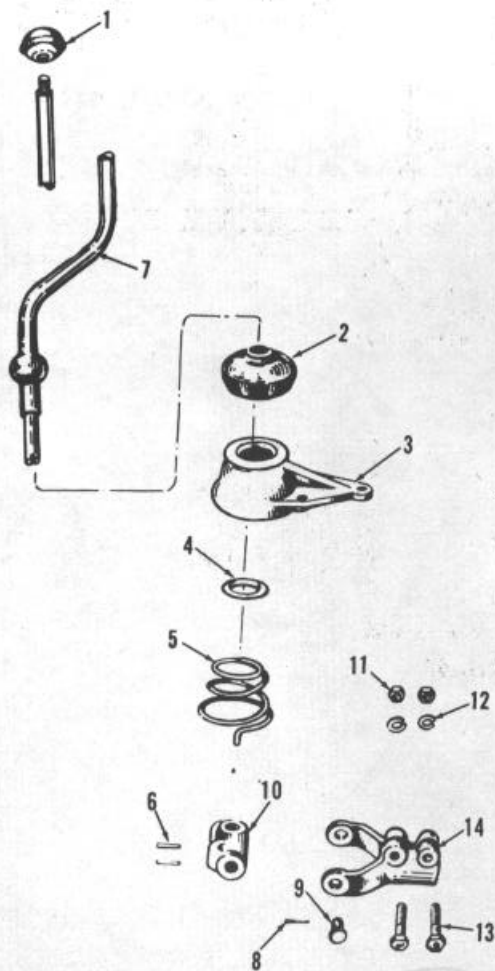

- 1 Knob
- 2 Cover
- 3 Bracket
- 4 Washer
- 5 Spring
- 6 Pin
- 7 Lever
- 8 Cotter pin
- 9 Pin
- 10 Lever end
- 11 Nut
- 12 Lockwasher
- 13 Capscrew
- 14 Bracket

B—Shift Lever Assembly

MEC 3810-227-15/150 ①

Figure 150. Transmission control rod assemble., removal and installation.

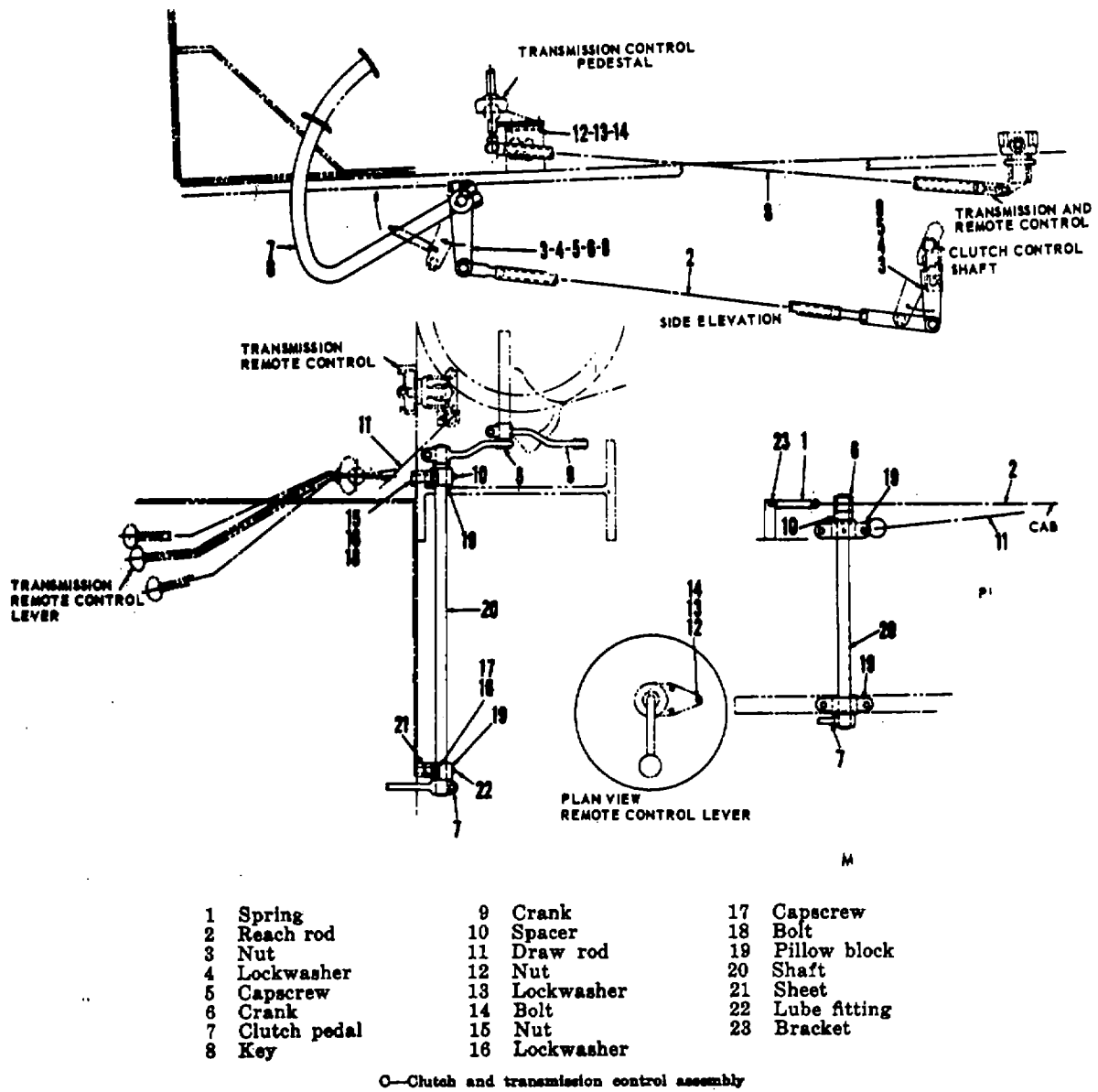
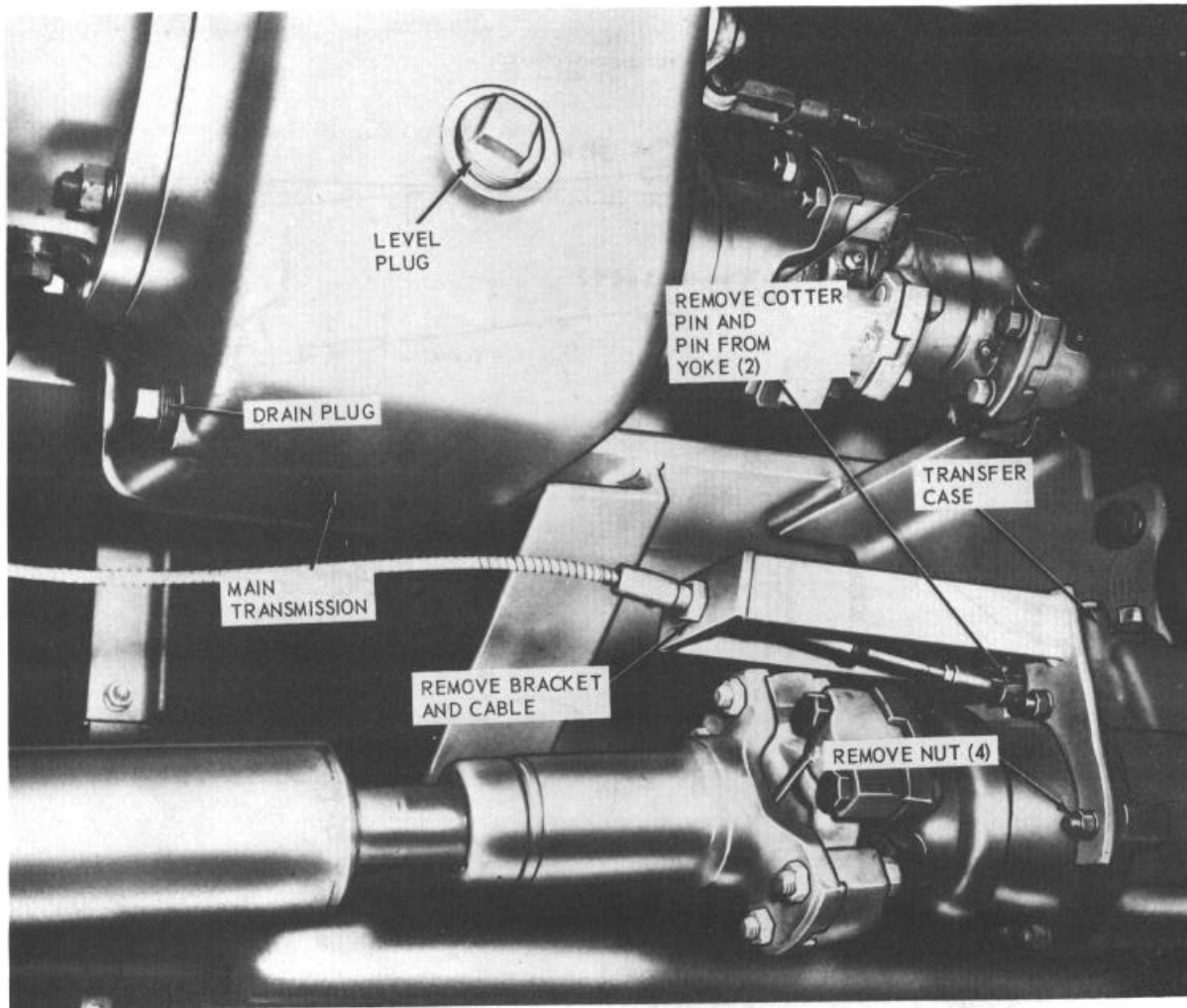

Figure 150. - Continued.





MEC 3810-227-15/151

Figure 151. Transfer case levers, and control rods, removal and installation.

## Section XXVII. CARRIER FRAME

### 247. General

The carrier frame is a welded-steel structure with crossmembers, supporting brackets, and front outrigger frame welded integrally with the frame. The rear outrigger assembly is mounted at the back of the frame and is removable. The carrier frame supports and carries the crane and all components. A pintle hook is mounted on the rear outrigger assembly for towing purposes.

### 248. Pintle Hook

a. *Removal and Disassembly.* Remove and disassemble the pintle hook in the numerical sequence as instructed on figure 152.

b. *Cleaning, Inspection, and Repair.*

- (1) Clean all parts with an approved cleaning solvent.
- (2) Inspect all parts for defective conditions.
- (3) Repair or replace damaged parts as necessary.

c. *Reassembly and Installation.* Reassemble and install the pintle hook in the reverse of the numerical sequence as illustrated on figure 152.

#### 249. Outrigger Assemblies

##### a. *Removal.*

- (1) Remove the floats from the outrigger assembly.
- (2) Remove the outrigger assembly from the frame.

b. *Disassembly.* Disassemble the outrigger assembly and the outrigger beams as instructed on figure 153.

##### c. *Cleaning, Inspection, and Repair.*

- (1) Clean all parts with an approved cleaning solvent.
- (2) Inspect all parts for defective conditions.
- (3) Repair or replace damaged parts as necessary.

d. *Reassembly.* Reassemble the outrigger beams and the outrigger assembly as illustrated on figure 153.

##### e. *Installation.*

- (1) Install the outrigger assembly on the carrier frame.
- (2) Install the floats on the outrigger assembly.

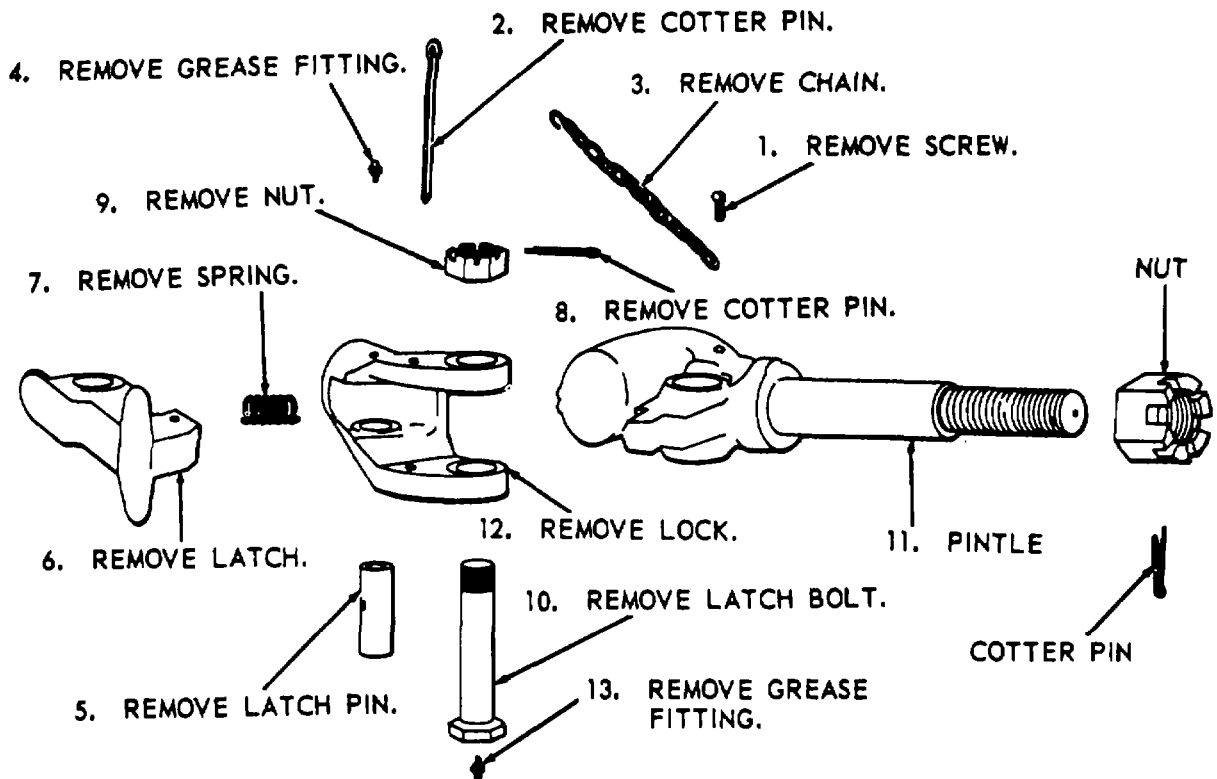

MEC 3810-227-15/152

Figure 152. Pintle hook assembly.

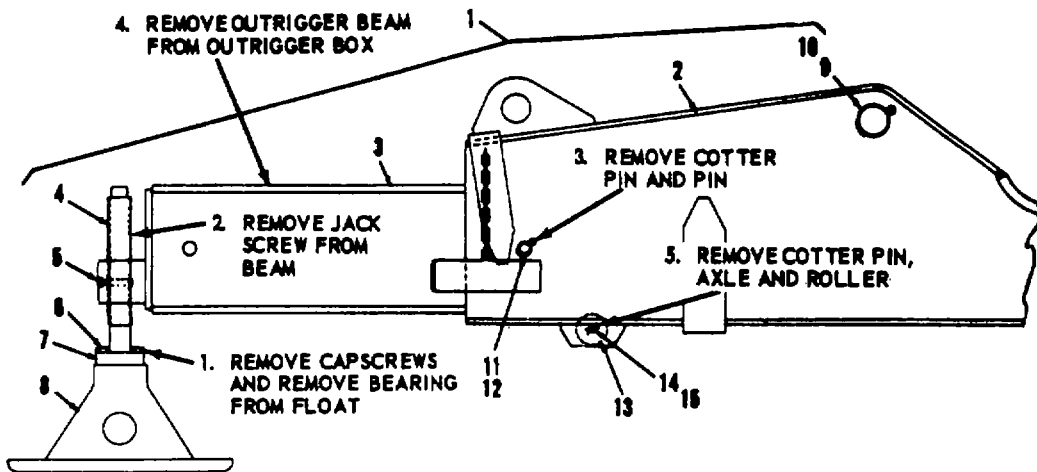
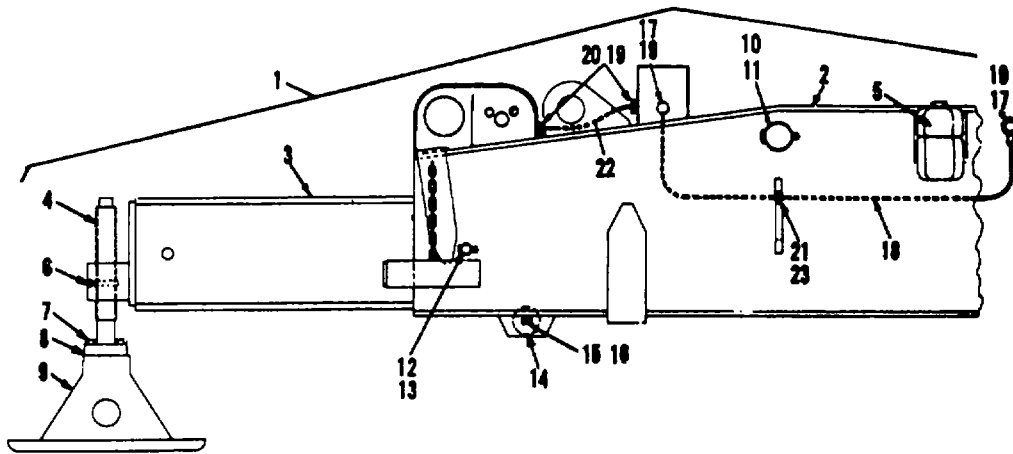

MEC 3810-227-15/153

- |                           |                            |                  |
|---------------------------|----------------------------|------------------|
| 1 Rear outrigger assembly | 9 Float                    | 17 Conduit elbow |
| 2 Outrigger box           | 10 Pin                     | 18 Conduit       |
| 3 Outrigger beam          | 11 Cotter pin              | 19 Locknut       |
| 4 Jackscrew               | 12 Pin                     | 20 Bushing       |
| 5 Pintle assembly         | 13 Cotter pin              | 21 Strap         |
| 6 Lube fitting            | 14 Roller assembly         | 22 Conduit       |
| 7 Capscrew                | 15 Axle                    | 23 Nut           |
| 8 Bearing plate           | 16 Cotter pin              |                  |
|                           | A—Rear outrigger           |                  |
| 1 Outrigger assembly      | 6 Capscrew                 | 11 Pin           |
| 2 Outrigger box           | 7 Bearing plate            | 12 Cotter pin    |
| 3 Outrigger beam          | 8 Float                    | 13 Roller        |
| 4 Jackscrew               | 9 Pin                      | 14 Axle          |
| 5 Lube fitting            | 10 Cotter pin              | 15 Cotter pin    |
|                           | B—Front Outrigger Assembly |                  |

Figure 153. Outrigger assembly, front and rear.

## Section XXVII. CARRIER CAB AND FENDERS

### 250. General

The pressed steel-constructed carrier cab is mounted on the left-front side of the carrier frame. It is designed to accommodate only the driver. It can be removed as a complete unit. The front fenders are bolted in place and can be removed, if necessary, to facilitate overhaul of the carrier. The rear fenders are bolted to the side rails.

### 251. Windshield and Small Side Glasses

*a. Removal.* The windshield, small side glasses, are removed in the same manner as the door window and windshield glass in the crane (para. 210).

*b. Installation.* The windshield, small side glasses, are installed in the same manner as the door window and windshield glass in the crane (para. 210).

### 252. Side Window Glass, and Rear Window Glass

*a. Removal.* Remove the side window glass, and rear window glass, as instructed on figure 154.

*b. Cleaning and Inspection.*

- (1) Clean all parts with an approved cleaning solvent.

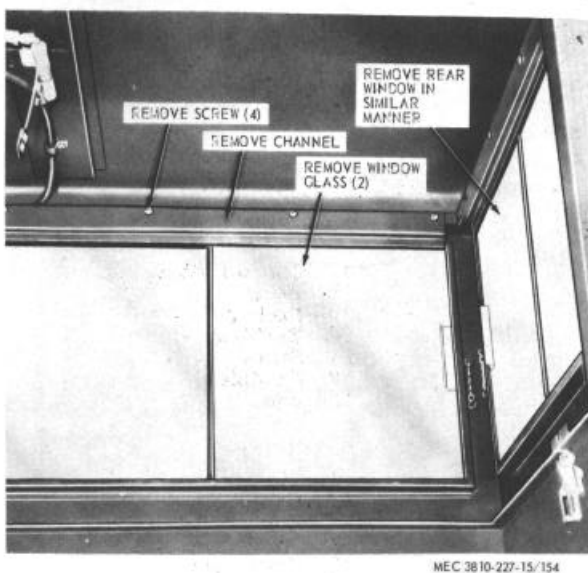

Figure 154. Side window glass, and rear window glass, removal and installation.

- (2) Inspect the window mounting gasket for damage and inspect glass for cracks and chipped edges.
- (3) Replace damaged parts as necessary.

*c. Installation.* Install the side window glass, and the rear window glass, as illustrated on figure 154.

### 253. Engine Access Panel

*a. Removal.* Remove the engine access panel as instructed on figure 155.

*b. Cleaning, Inspection, and Repair.*

- (1) Clean all parts with an approved cleaning solvent.
- (2) Inspect the access panel for cracks, bends, and dents. Weld all cracks. Replace an unrepairable panel.
- (3) Repair or replace damaged parts as necessary.

*c. Installation.* Install the engine access panel as illustrated on figure 155.

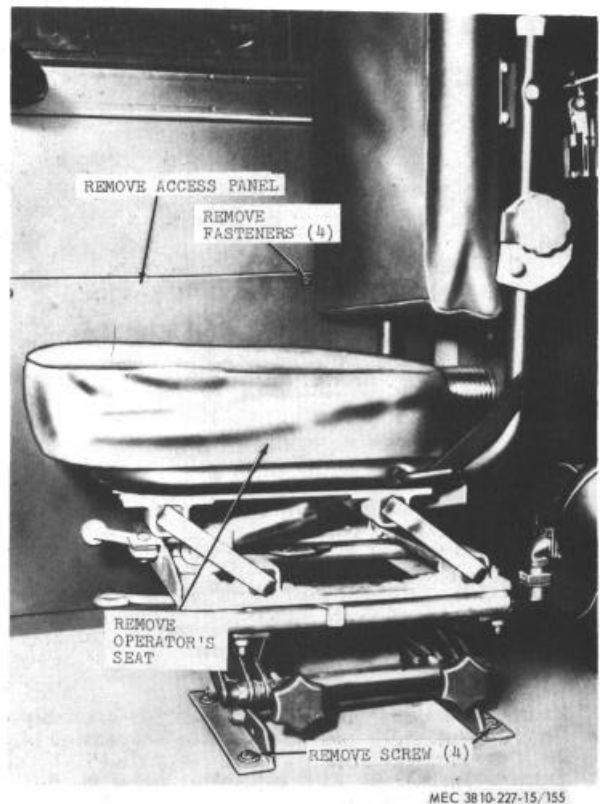

Figure 155. Engine access panel and operator's seat, removal and installation.

## 254. Operator's Seat

a. *Removal.* Remove the operator's seat from the cab as illustrated on figure 155.

b. *Disassembly.* Disassemble the operator's seat in the numerical sequence as instructed on figure 156.

c. *Cleaning, Inspection, and Repair.*

- (1) Clean all parts with an approved cleaning solvent, except the cushions. Use soap and water for cleaning cushions.

- (2) Inspect the cushions for torn or ripped covers and broken springs. Replace a damaged cushion as necessary.

- (3) Inspect the seat frame and suspension for cracks, breaks, and bends. Straighten bends and weld all cracks or breaks.

- (4) Repair or replace all defective parts as necessary.

d. *Reassembly.* Reassemble the operator's seat in the reverse of the numerical sequence as illustrated on figure 156.

e. *Installation.* Install the operator's seat as illustrated on figure 155.

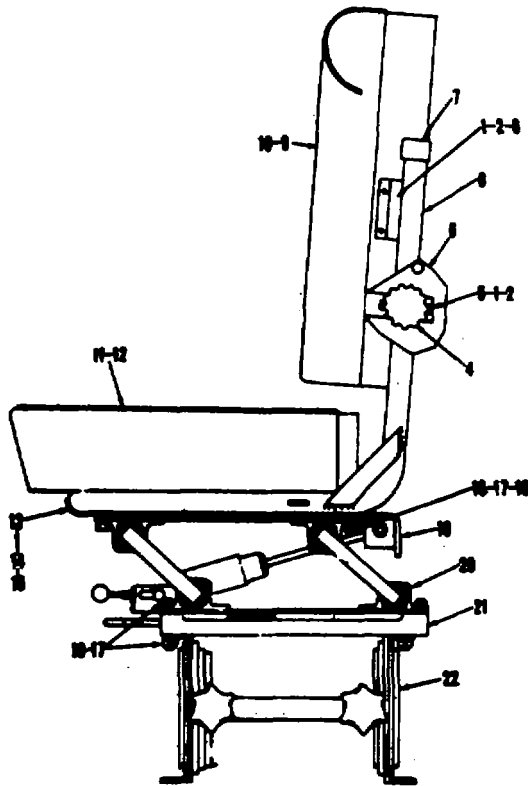

MEC 3810-227-15/156

1 Screw	13 Seat cover
2 Lockwasher	14 Bracket
3 Bracket	15 Lockwasher
4 Knob	16 Flat washer
5 Bracket	17 Capscrew
6 Locking plate	18 Lockwasher
7 Boot	19 Nut
8 Frame assembly	20 Shock absorber assembly
9 Back assembly	21 Shock free suspension
10 Back cover	22 Twin locking slide
11 Seat assembly	23 Adjustable pedestal

Figure 156. Operator's seat, disassembly and reassembly.

## 255. Cab Operator's Door

a. *Removal.* Remove the carrier cab operator's door as instructed on figure 157.

b. *Cleaning, Inspection, and Repair.*

- (1) Clean all parts with an approved cleaning solvent.

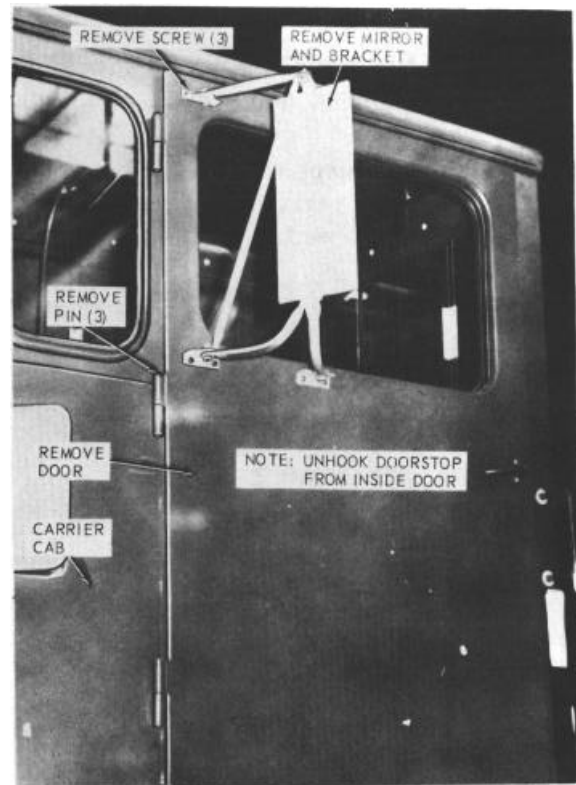

MEC 3810-227-15/157

Figure 157. Carrier cab door, removal and installation.

- (2) Inspect door for bends, dents, or broken hinges. Replace a defective door as necessary.
- (3) Repair or replace damaged parts as necessary.

c. *Installations.* Install the carrier cab operator's door as illustrated on figure 157.

## 256. Cab Floorboard

### a. Removal

- (1) Remove floor mat.
- (2) Remove the screws mounting the floorboard to the frame.
- (3) Remove the floorboard from the frame.

### b. Cleaning, Inspection, and Repair.

- (1) Clean all parts with an approved cleaning solvent.
- (2) Inspect floorboard for bends, cracks, rust, and other damage.
- (3) Replace or repair all defective parts as necessary.

### c. Installation.

- (1) Position the floorboard on the frame.
- (2) Install the screws in the floorboard, securing the floorboard to the frame.
- (3) Install the floormat.

## 257. Windshield Wiper Motor and Automatic Low-Pressure Signal

### a. Removal and Installation.

- (1) Remove and install windshield wiper motor assembly as instructed in figure 158.
- (2) Remove and install low-pressure Wig-Wag signal as instructed in figure 158.

### b. Cleaning and Inspection.

- (1) Clean all parts with an approved cleaning solvent and dry thoroughly.
- (2) Inspect for cracks, breaks, and proper operation.
- (3) Replace a damaged or defective windshield wiper motor or low-pressure signal as necessary,

## 258. Engine Hood and Side Panel

### a. Removal.

- (1) Remove the battery cables and box (para. 103).

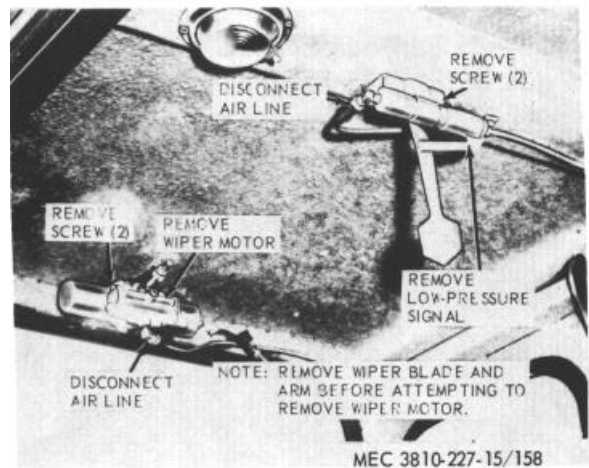

Figure 158. Windshield wiper motor and low-pressure signal, removal and installation.

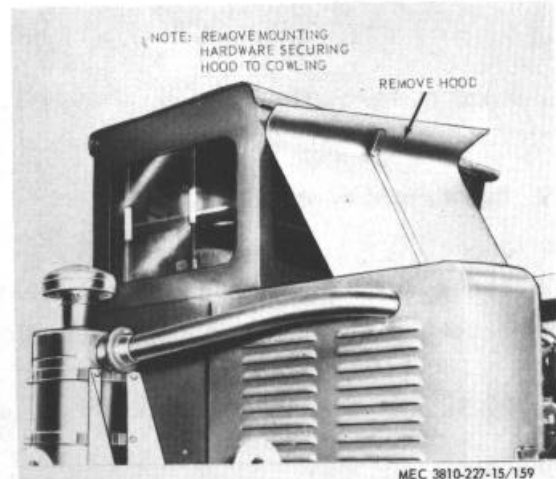

Figure 159. Engine hood and side panel, removal and installation.

- (2) Remove the engine hood and side panel as instructed in figure 159.

### b. Cleaning, Inspection, and Repair.

- (1) Clean all parts with an approved cleaning solvent.
- (2) Inspect the hood panels for cracks or dents. Pound out dents and weld all cracks as necessary.
- (3) Repair or replace damaged parts as necessary.

### c. Installation.

- (1) Install the engine hood and side panel as illustrated on figure 159.
- (2) Install the battery box and cables (para. 103).

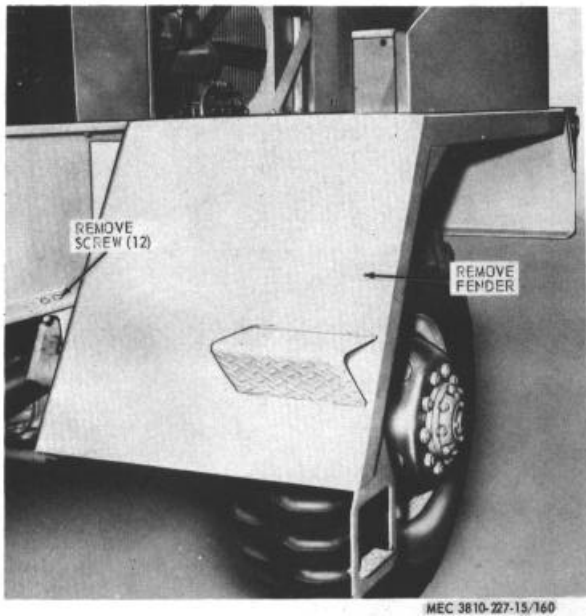

**Figure 160. Carrier right-front fender, removal and installation.**

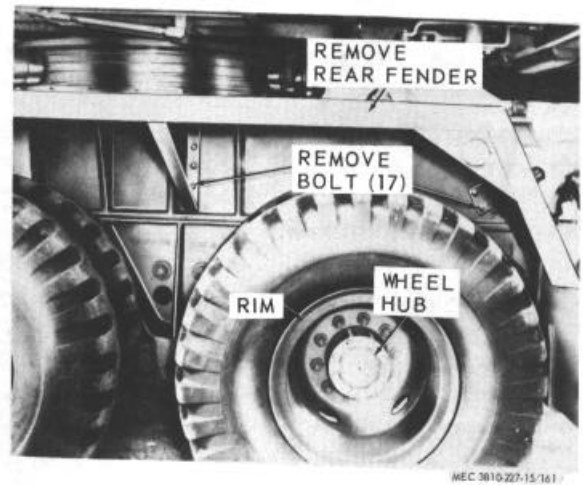

**Figure 161. Carrier rear fender, removal and installation.**

- (2) Install the engine hood and side panel (para. 258).
- (3) Install the battery box (para 103).

## 259. Right-Front Fender

### a. Removal.

- (1) Remove the battery box (para. 103).
- (2) Remove the engine hood and side panel (para. 258).
- (3) Remove the right-front fender as instructed on figure 160.

### b. Cleaning, Inspection, and Repair.

- (1) Clean all parts with an approved cleaning solvent.
- (2) Inspect the fender for damage. Replace a damaged fender.
- (3) Inspect the braces for cracks or breaks. Replace a damaged brace.
- (4) Repair or replace damaged parts as necessary.

### Note

**Minor bends or dents may be straightened and breaks welded.**

### c. Installation.

- (1) Install the right-front fender as illustrated on figure 160.

## 260. Rear Fenders

a. *Removal.* Remove the carrier rear fenders as instructed on figure 161.

### b. Cleaning, Inspection, and Repair.

- (1) Clean all parts with an approved cleaning solvent.
- (2) Inspect the fender for cracks, breaks, or bends.
- (3) Repair or replace damaged parts as necessary.

c. *Installation.* Install the carrier rear fenders as illustrated on figure 161.

## 261. Cab and Left-Front Fender

a. *Inspection.* Inspect the cab and left-front fender for breaks, cracks, dents, holes, rust, and broken braces.

b. *Repair.* Weld all cracks, breaks, holes and broken braces of the cab and left-front fender. Remove all dents and refer to TB ENG 60 for painting a repaired cab or fender.

## Section XXIX. CARRIER WINTERIZATION EQUIPMENT

### 262. General

The gas-fired liquid heater (A, fig. 16) mounted to the front crossmember just in front of the right front wheel, is used as a cold-weather engine starting aid by use of an electric powered circulating pump, heats and circulates the engine coolant throughout the engine cooling system and the jacket on the oil pan. The gas-fired fresh air heater, mounted to the rear of the carrier engine housing heats the operator's cab, battery box and window defrosters. A fuel pump, lines, filter and fittings furnish fuel for the heater assemblies. A radiator shutter is supplied and is also used as a cold-weather engine starting aid.

### 263. Heater Fuel Pump Filter Element Service

Service both heater fuel pump filter elements as instructed in figure 162.

### 264. Heater Fuel Pump Screen Service

Service both heater fuel pump screens as instructed in figure 162.

### 265. Heater Fuel Pump and Filter

a. *Removal and Installation.* Remove and install the fuel pump and filters as instructed on figure 166.

b. *Cleaning and Inspection.*

- (1) Clean all parts with an approved cleaning solvent and dry thoroughly.
- (2) Inspect all mounting hardware for damage. Replace damaged mounting hardware as necessary.
- (3) Inspect the fuel pumps and filters for breaks, leaks, and other damage. Replace fuel pumps and filters as necessary.
- (4) Inspect the fuel pump for proper operation. Replace a defective fuel pump.

### 266. Heater Control Boxes

a. *General.*

- (1) The control boxes for both the engine liquid heater and the cab fresh air

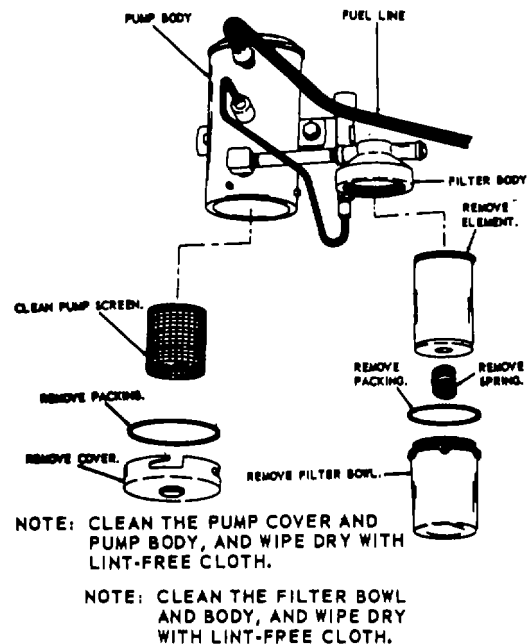

MEC 3810-227-15/162

Figure 162. Carrier heater fuel pump screen and fuel pump filter service.

heater are identical and maintenance instructions are the same for both units.

- (2) Remove the two screws (1 figure 163) on each side of the name plate (3) and separate the box assembly (4) from the control box panel (24). Inspect the assembly Visually for wiring defects and faulty parts. Check the circuits, using the wiring diagram (fig. 164). Replace any units that are obviously faulty. Disassemble and test the control box components as follows.

b. *Circuit Breaker.*

- (1) To remove the circuit breaker (12, fig. 163) disconnect the electrical leads from the terminals. Tag leads to facilitate reassembly. Remove the two mounting screws (2) from the panel and remove the circuit breaker.
- (2) To test, connect the circuit breaker to a test circuit which will supply 200 percent rated current. Press in the



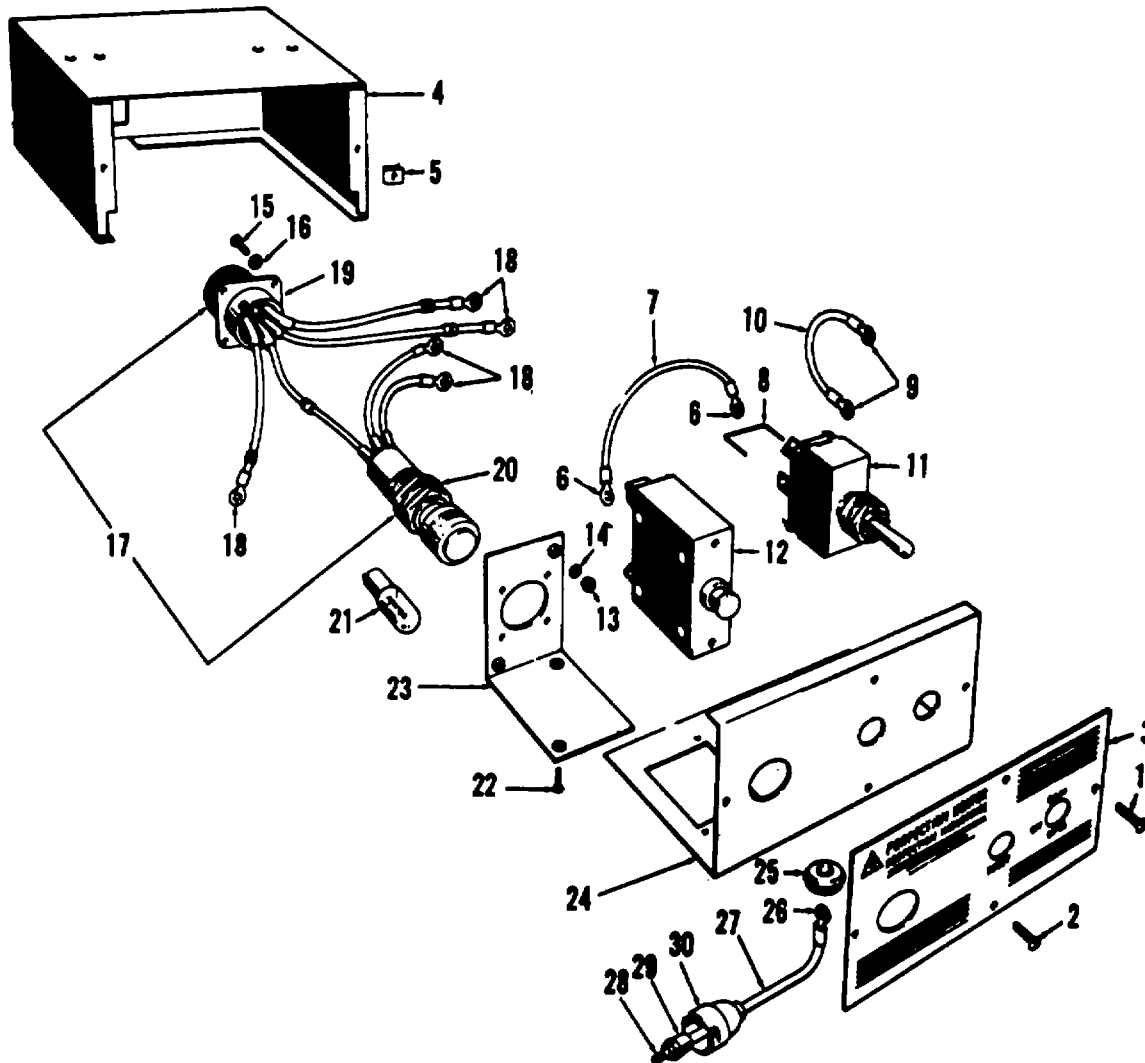

MEC 3810-227-15/163

- |                         |                        |                   |
|-------------------------|------------------------|-------------------|
| 1 Screw, mach.          | 11 Switch, control     | 21 Lamp           |
| 2 Screw, mach.          | 12 Circuit breaker     | 22 Screw, rd-hd   |
| 3 Plate, name           | 13 Nut, hex            | 23 Bracket, angle |
| 4 Box assembly, control | 14 Washer, lock        | 24 Panel          |
| 5 Clip                  | 15 Screw, mach.        | 25 Grommet        |
| 6 Terminal              | 16 Washer, lock        | 26 Terminal       |
| 7 Wire assembly         | 17 Receptacle terminal | 27 Wire assembly  |
| 8 Wire, jumper          | 18 Terminal            | 28 Terminal       |
| 9 Terminal              | 19 Receptacle          | 29 Grommet        |
| 10 Wire assembly        | 20 Socket, light       | 30 Shell          |

Figure 185. Control box assembly.

reset button; the circuit breaker should open within 10 to 125 seconds. If it fails to meet this requirement, replace the circuit breaker.

- (3) To install the circuit breaker, position it on the panel and fasten in place with the two mounting screws. Connect the leads as

indicated in the wiring diagram (fig. 164).

c. *Control Switch.*

- (1) To replace the control switch (11, fig. 168), disconnect the electrical leads. Tag leads-to facilitate reassembly. Remove the mounting nut from the

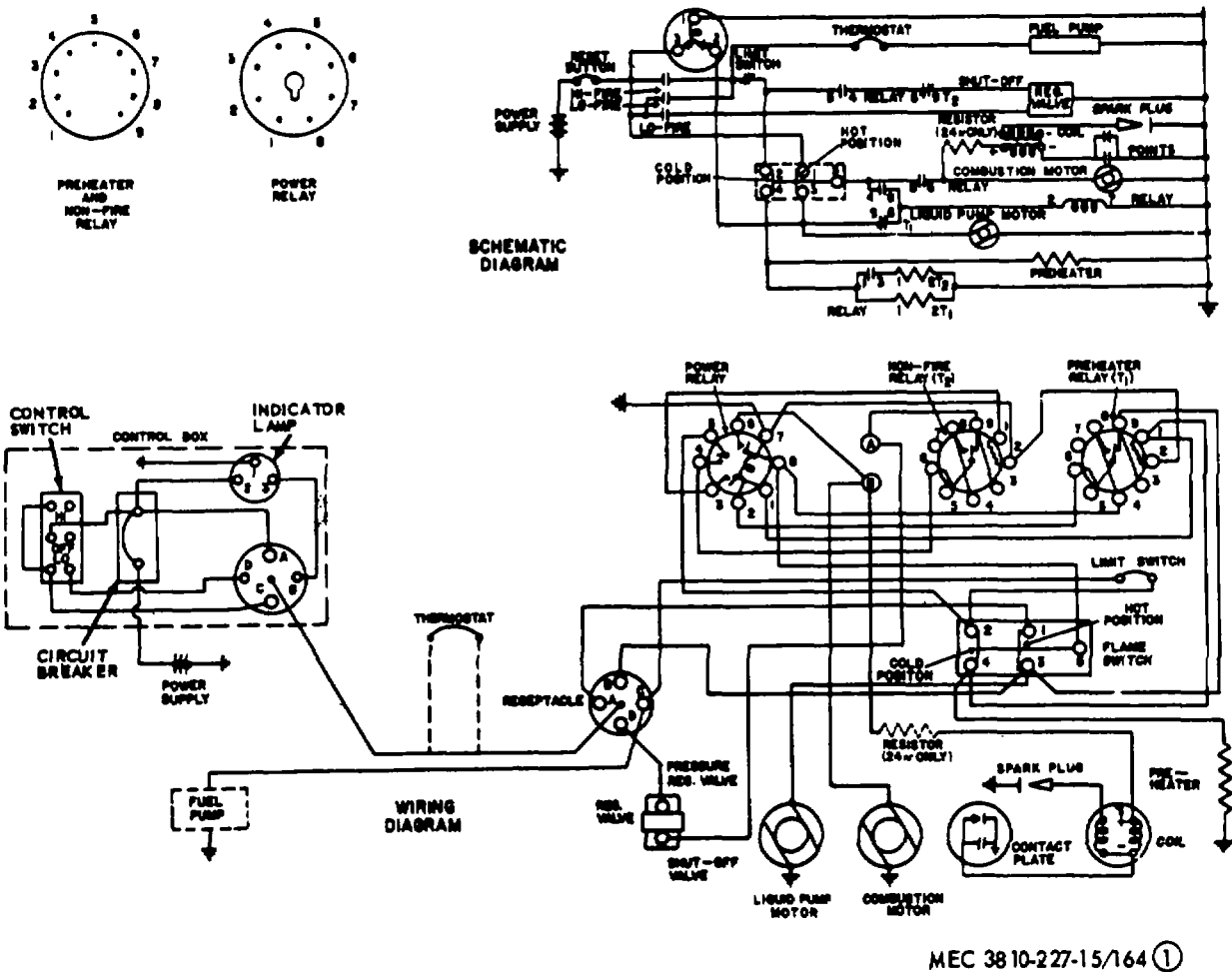

Figure 164. Engine liquid coolant heater wiring diagram.

threaded lever lug. Remove the control switch from the panel (24).

- (2) Check switch continuity with an ohmmeter in all positions. Make sure the switch operates freely. Replace if faulty.
- (3) To install the control switch, position on the panel and secure with the mounting nut. (Make certain the switch lever correctly indicates "ON-HI, OFF, ON-LO" operation on the plate). Connect the leads as indicated in the wiring diagram (fig. 164).

d. Indicator Lamp.

- (1) To replace the indicator lamp (21, fig. 163), remove the lamp button from the

light socket (20) then remove lamp.

- (2) To replace the light socket (20) or the box receptacle (19) remove both as an assembly (17). Disconnect the wires leading to the control switch, circuit breaker, and ground. To remove receptacle, remove the screws (15), washers (14 and 16), and nuts (13) fastening the receptacle to the angle bracket (23). Remove the light socket by removing the lamp button and the external mounting nut. Inspect the indicator light socket and receptacle for broken leads or worn or damaged threads. If any parts are faulty, replace the entire assembly.

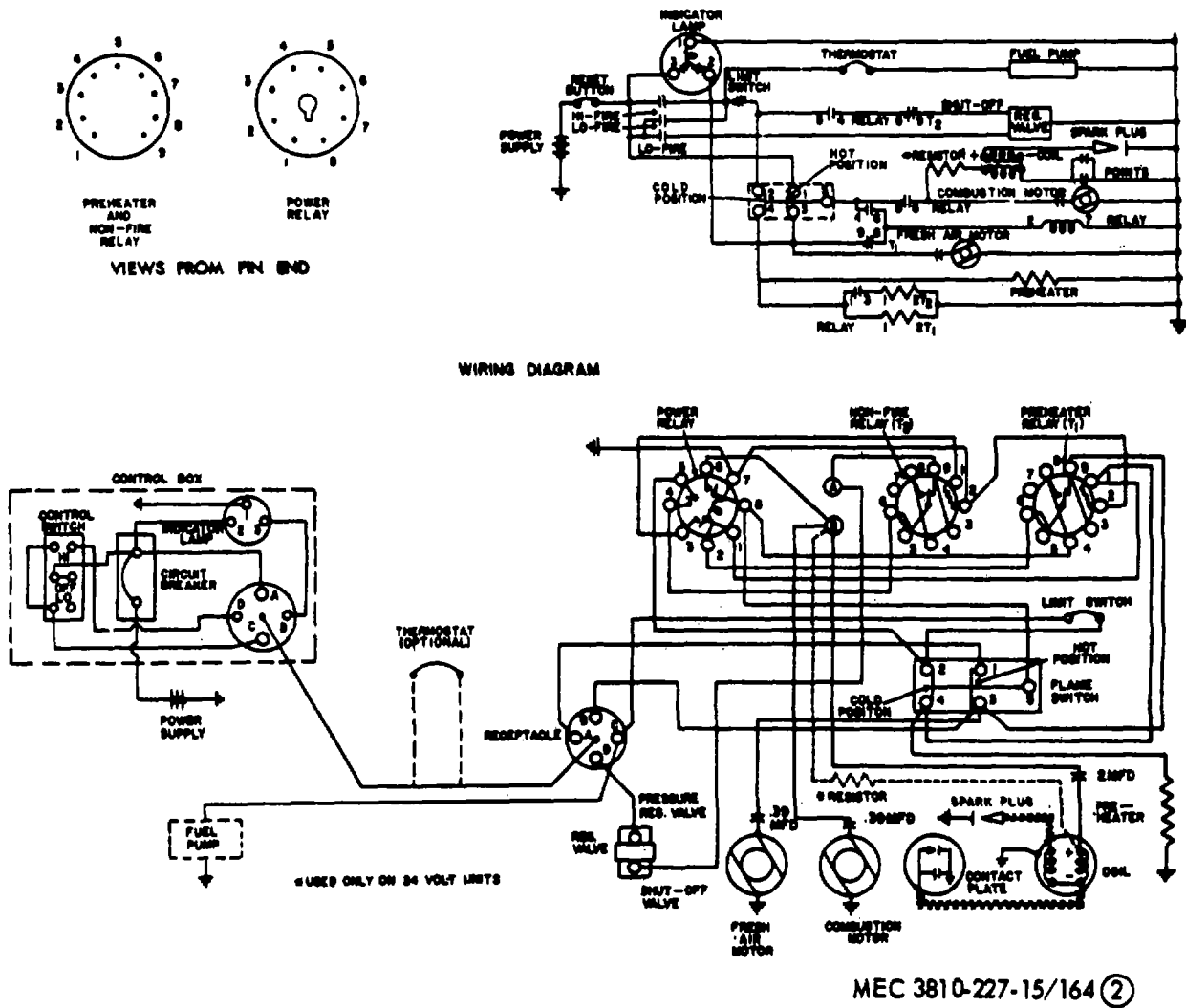

Figure 164. Continued.

- (3) To install the light socket and receptacle assembly, insert the light socket through the hole in the angle bracket (28) and install the internal mounting nut. Place the light socket in mounting position on the panel and fasten with the external mounting nut. Allow for "press-to-test" button movement by adjusting the light socket mounting position. Install the lamp and button.
- (4) Fasten the receptacle to the angle bracket with the mounting screws, washers, and nuts. Connect the wires according to the wiring diagram (fig. 164). The ground

wire from the lamp connects to a receptacle mounting nut.

### 267. Engine Heater Assembly

a. *Removal and Installation.* Remove and install carrier engine heater assembly as instructed on figure 165.

b. *Cleaning and Inspection.*

- (1) Clean the heater and mounting hard

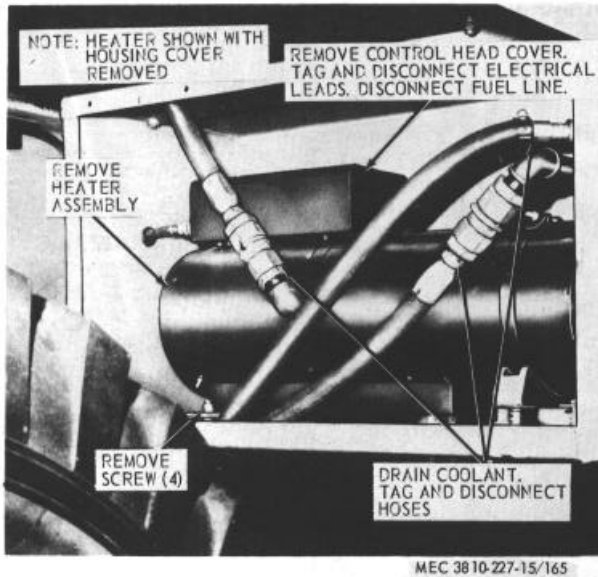

**Figure 165. Carrier engine liquid heater assembly, removal and installation.**

ware with an approved cleaning solvent and dry thoroughly.

- (2) Inspect the heater and mounting hardware for breaks, or other damage.
- (3) Inspect the heater for proper operation.
- (4) Replace or repair mounting hardware as necessary.
- (5) Replace a defective heater as necessary.

#### **268. Engine Heater Electric Coolant Pump**

*a. Removal and Installations.* Remove and install electric coolant pump as instructed on figure 166.

*b. Cleaning and Inspection.*

- (1) Clean the coolant pump and mounting hardware with an approved cleaning solvent and dry thoroughly.
- (2) Inspect the pump and mounting hardware for breaks or other damage.
- (3) Replace a defective pump or damaged hardware.

#### **269. Engine Heater Coolant Lines, Hoses and Fittings**

*a. Removal and Installation.* Remove and install engine heater coolant hoses and fittings as shown in figures 165 and 166.

*b. Cleaning and Inspection.*

- (1) Clean all hoses, lines, and fittings with an approved cleaning solvent and dry thoroughly.
- (2) Inspect the hoses, lines, and fittings for damaged threads, wear, signs of leakage or other damage.
- (3) Replace any damaged or defective parts.

#### **270. Cab and Components Heater Assembly**

*a. Removal and Installation.* Remove and install cab heater as instructed on figure 166.

*b. Cleaning and Inspection.*

- (1) Clean the heater and mounting hardware with an approved cleaning solvent and dry thoroughly.
- (2) Inspect the heater and mounting hardware for breaks, or other damage.
- (3) Inspect heater for proper operation.
- (4) Replace or repair mounting hardware as necessary.
- (5) Replace a defective or damaged heater.

#### **271. Cab Heater Duds and Defrosters**

*a. Removal and Installation.* Remove and install heat ducts and defrosters as instructed on figure 167.

*b. Cleaning and Inspection.*

- (1) Clean all parts in an approved cleaning solvent and dry thoroughly.
- (2) Inspect the defroster boxes for bends, breaks and other damage. Repair or replace a defective defroster box as necessary.
- (3) Inspect all duct work and hardware for damage. Replace damaged or defective parts as necessary.
- (4) Replace a damaged or defective heat control.

#### **272. Radiator Shutter Assembly**

*a. Removal and Installation.* Remove and install carrier radiator shutter assembly as instructed on figure 168.

*b. Cleaning and Inspections*

- (1) Clean the radiator shutter with an approved cleaning solution.
- (2) Inspect the radiator shutter for breaks, bends, and other damage. Repair or replace damaged radiator shutter and mounting hardware as necessary.

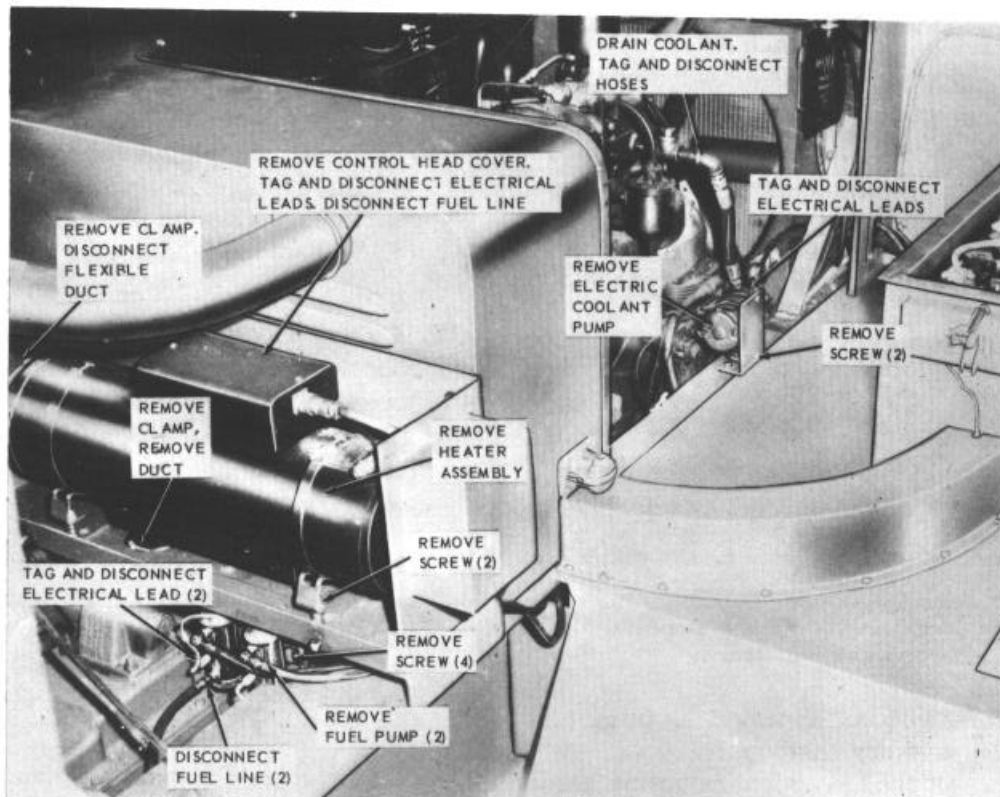

A - Cab Heater Components.

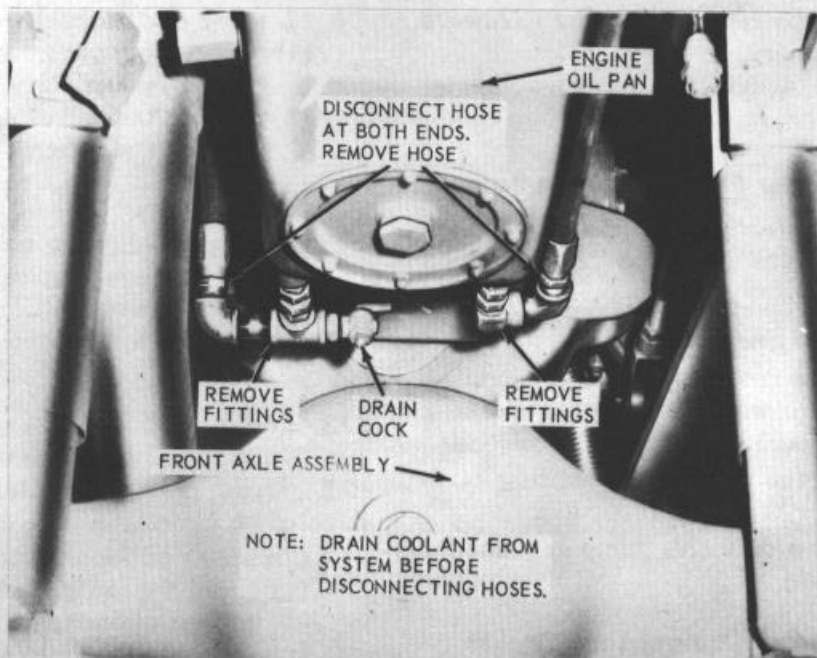

B - Oil Pan Heater Coolant Lines.

MEC 3810-227-15/166

Figure 166. Carrier cab heater and engine heater components, removal and installation.

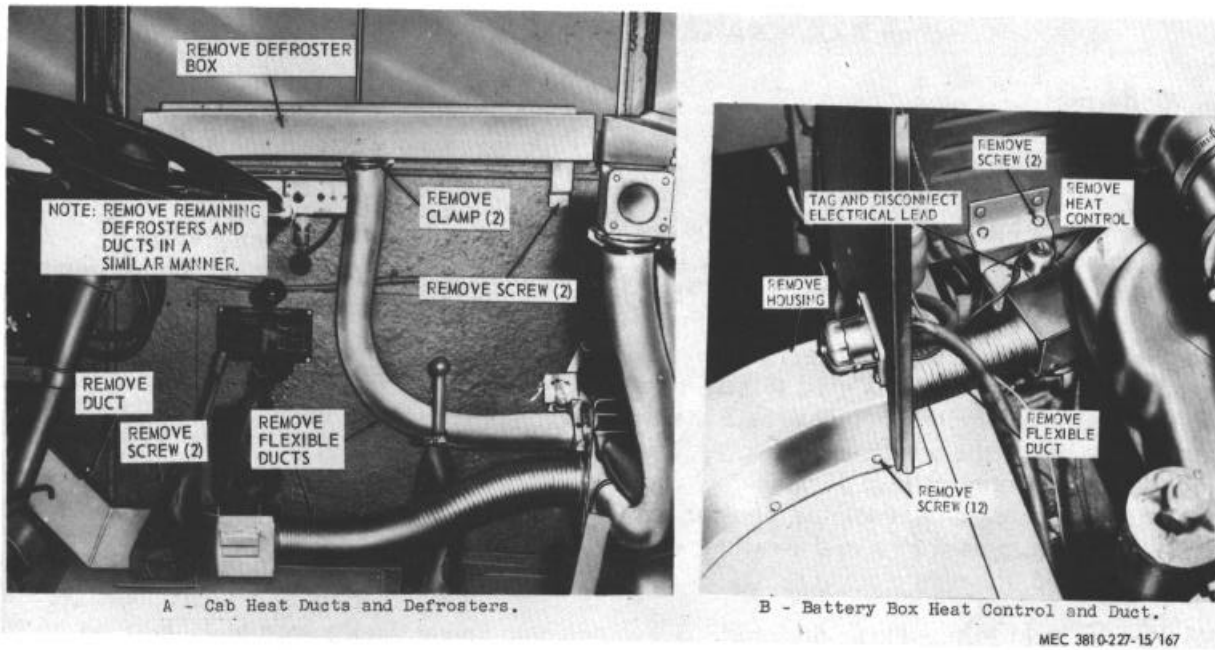

Figure 167. Carrier cab heat duct and defrosters, removal and installation.

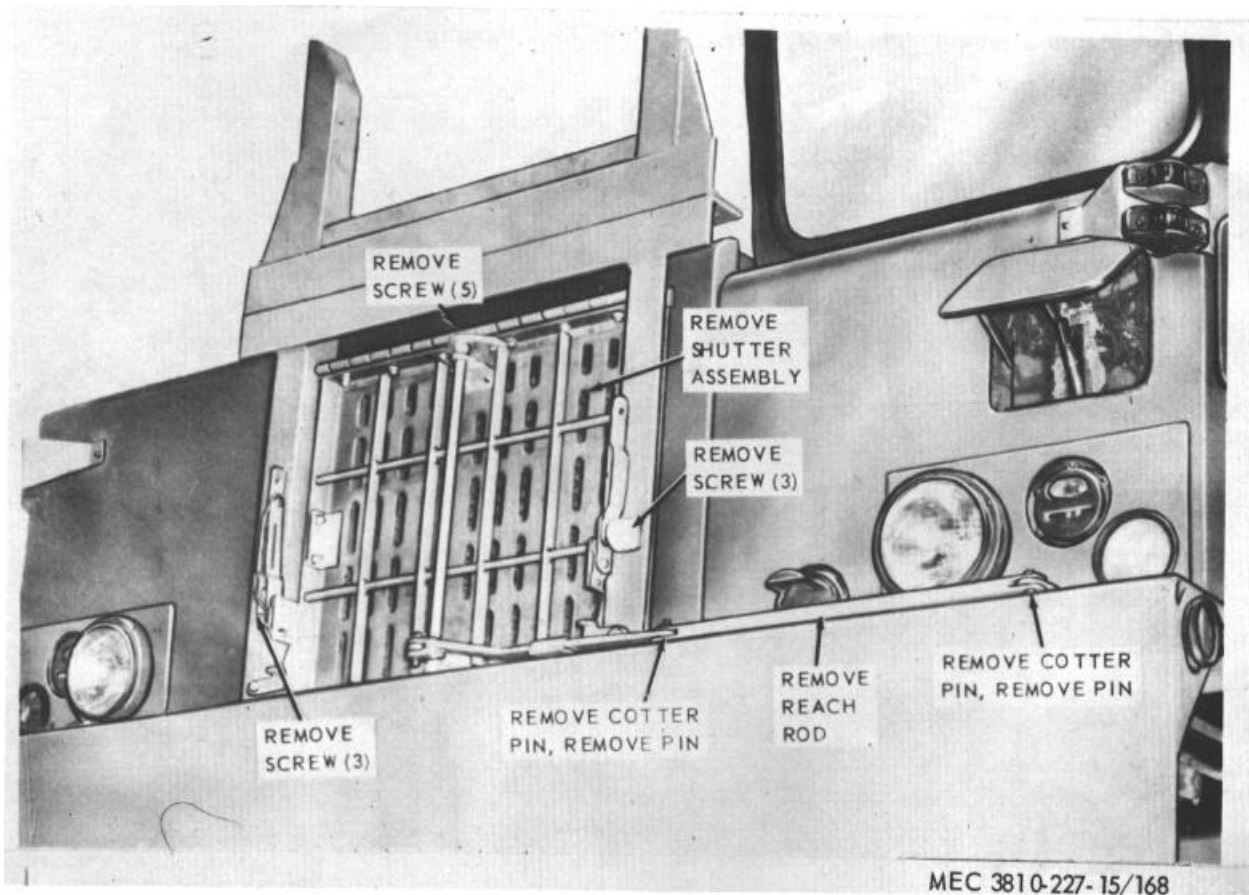

Figure 168. Carrier radiator shutter assembly, removal and installation.

## Section XXX. CRANE WINTERIZATION EQUIPMENT.

### 273. General

The gas-fired liquid heater, mounted at the right rear of the crane-shovel cab under the machinery deck is used as a cold-weather engine starting aid, by use of an electric powered circulating pump, heats and circulates the engine coolant throughout the engine cooling system and the jacket on the oil pan. The gas-fired fresh air heater, mounted on the right hand side of the crane-shovel cab is used to heat the operator's cab, battery box, window defrosters and heat box below the machinery deck. A fuel pump, lines, filter, and fittings furnish fuel for the heater assemblies. A radiator shutter is supplied and is also used as a cold-weather, engine starting aid.

### 274. Heater Fuel Pump Filter Element Service

Service the crane heater fuel pump filters in the same manner as instructed for carrier heater fuel pump filter service (para. 263).

### 275. Heater Fuel Pump Screen Service

Service the crane heater fuel pump screens in the same manner as instructed for carrier heater fuel pump screens (para. 264).

### 276. Heater Fuel Pump and Filter

a. *Removal and Installation.* Remove and install the fuel pumps and filters as instructed on figure 169.

b. *Cleaning and Inspection.*

- (1) Clean all parts with an approved cleaning solvent and dry thoroughly.
- (2) Inspect all mounting hardware for damage. Replace damaged mounting hardware as necessary.
- (3) Inspect the fuel pumps and filters for breaks, leaks and other damage. Replace fuel pumps and filters as necessary.
- (4) Inspect the fuel pumps for proper operation. Replace a defective fuel pump.

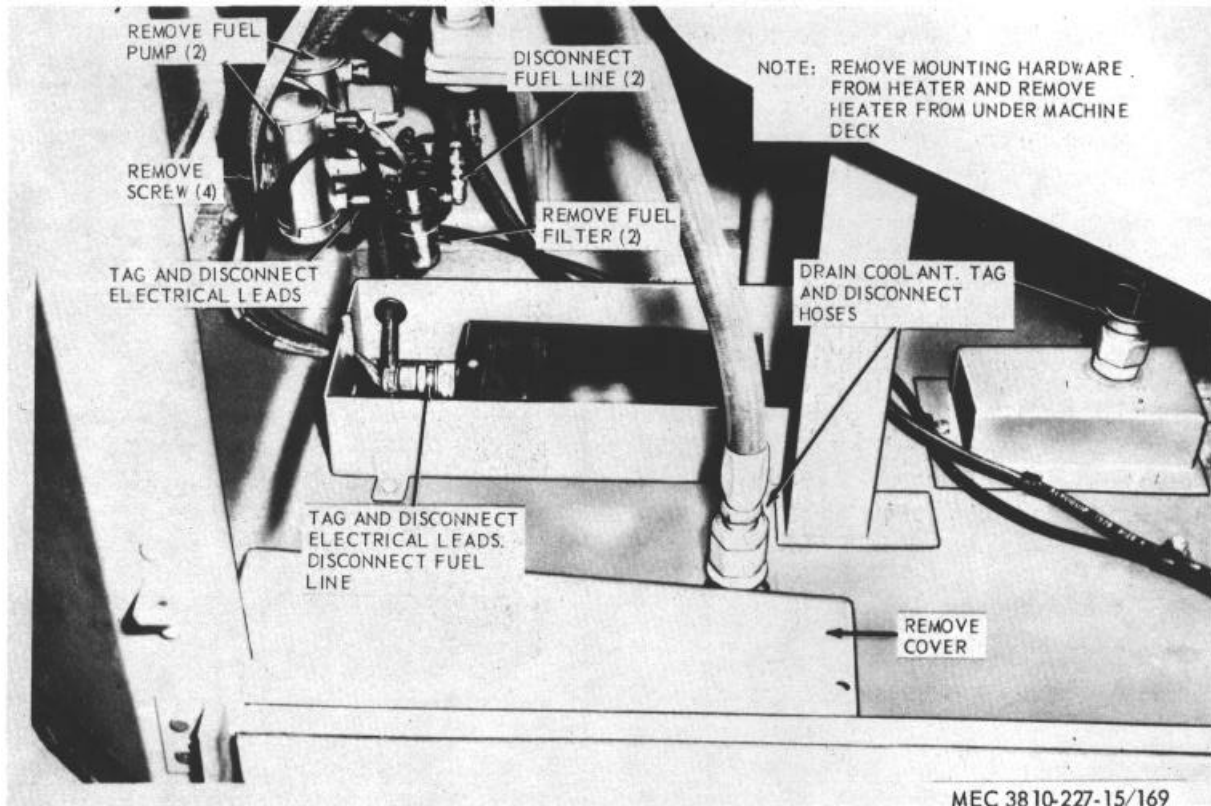

Figure 169. Crane engine liquid heater assembly, fuel pumps and filters, removal and installation.

## 277. Heater Control Boxes

The control boxes for both the engine liquid heater and the cab fresh air heater are identical and maintenance instructions are the same for both units. Service the crane heater control boxes in the same manner as instructed for carrier heater control boxes (para. 266).

## 278. Engine Heater Assembly

### a. Removal and Installation

- (1) Disconnect coolant hoses and electrical leads as instructed on figure 169.
- (2) Remove mounting screws in a similar manner as instructed for carrier engine heater figure 165, and remove heater from under machine deck.

### b. Cleaning and Inspection

- (1) Clean the heater and mounting hardware with an approved cleaning solvent and dry thoroughly.
- (2) Inspect the heater and mounting hardware for breaks or other damage.
- (3) Inspect the heater for proper operation.
- (4) Replace or repair mounting hardware as necessary.
- (5) Replace a defective heater as necessary.

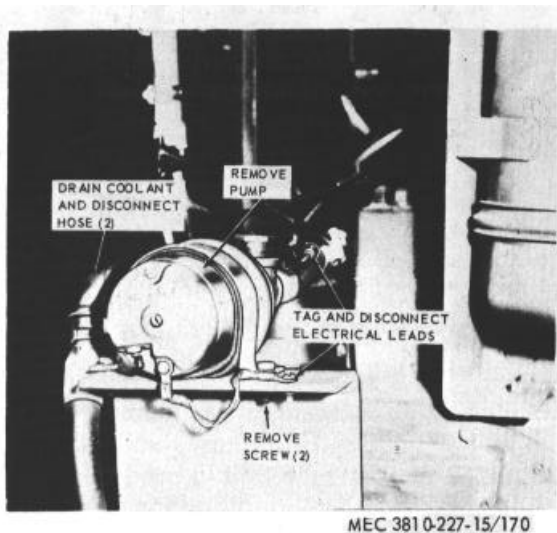

Figure 170. Crane engine heater electric coolant pump, removal and installation.

## 279. Engine Heater Electric Coolant Pump

a. *Removal and Installation.* Remove and install electric coolant pumps as instructed on figure 170.

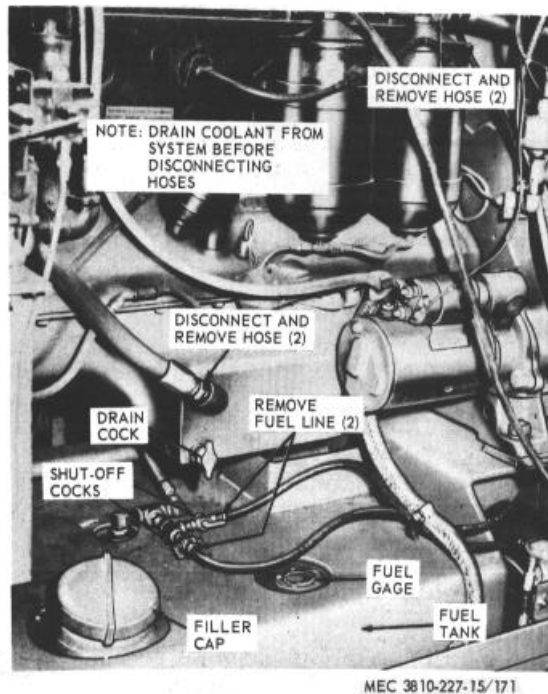

Figure 171. Crane engine heater coolant lines and fuel lines, removal and installation.

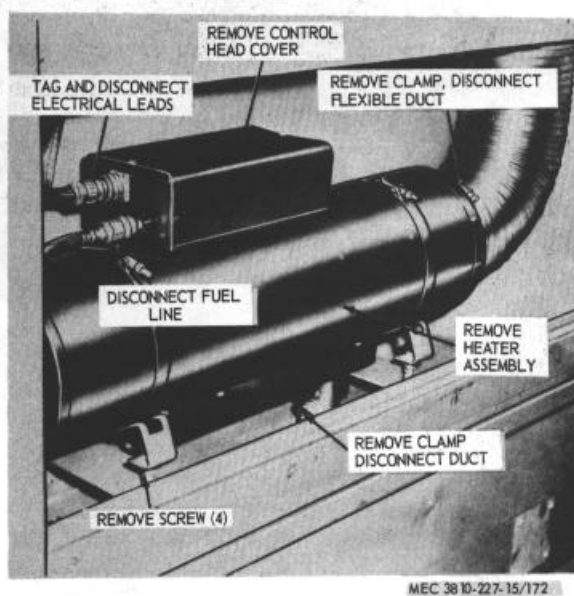
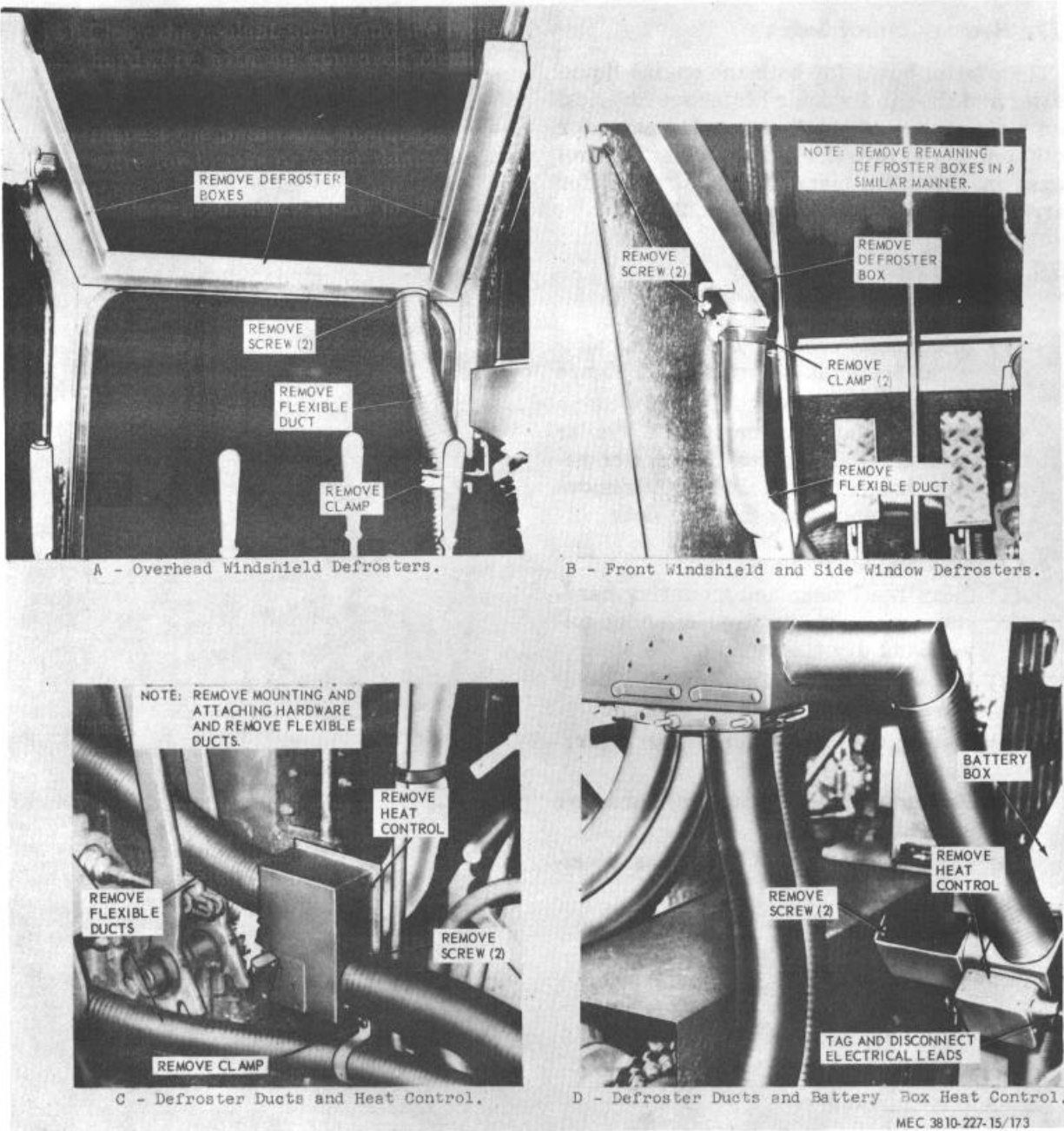

Figure 172. Crane cab heater, removal and installation.





**Figure 175. Crane cab defrosters and heat ducts, removal and installation.**

**b. Cleaning and Inspection.**

- (1) Clean the coolant pump and mounting hardware with an approved cleaning solvent and dry thoroughly.
- (2) Inspect the pump and mounting hardware for breaks or other damage.
- (3) Replace a defective pump or damaged hardware.

**280. Engine Heater Coolant Lines, Hoses and Fittings**

**a. Removal and Installation.** Remove and install heater coolant lines, hoses and fittings as illustrated in figures 169, 170, and 171.

**b. Cleaning and Inspection.**

- (1) Clean all hoses, lines, and fittings with an approved cleaning solvent and dry thoroughly.

- (2) Inspect the hoses, lines, and fittings for damaged threads, breaks, signs of leakage or other damage.
- (3) Replace any damaged or defective parts.

### 281. Cab and Components, Heater Assembly

a. *Removal and Installation.* Remove and install the cab heater as instructed on figure 172.

b. *Cleaning and Inspection.*

- (1) Clean the heater and mounting hardware with an approved cleaning solvent and dry thoroughly.
- (2) Inspect the heater and mounting hardware for breaks, or other damage.
- (3) Inspect heater for proper operation.
- (4) Replace or repair mounting hardware as necessary.
- (5) Replace a defective or damaged heater.

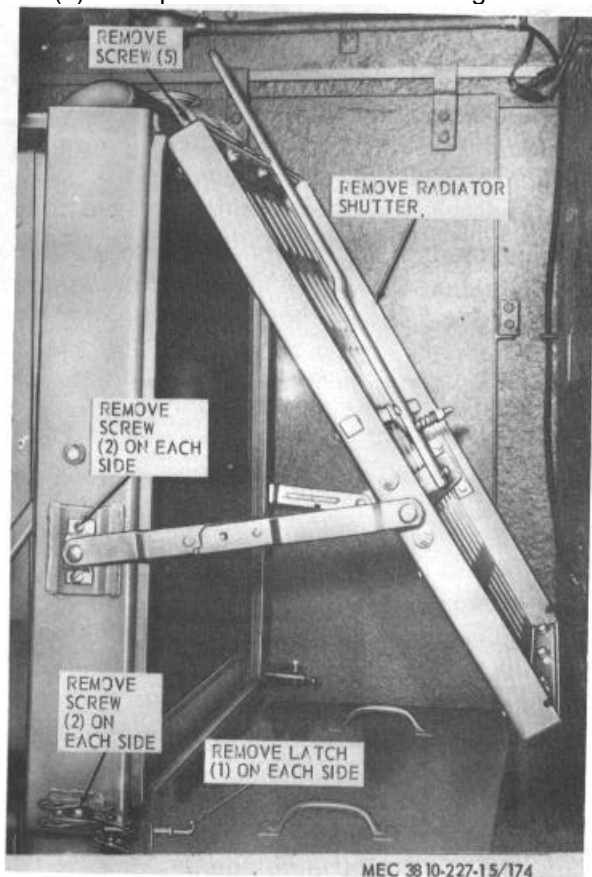

Figure 174. Crane radiator shutter, removal and installation.

### 282. Cab Heater Ducts and Defrosters

a. *Removal and Installation.* Remove and install heat ducts and defrosters as instructed on figure 173.

b. *Cleaning and Inspection.*

- (1) Clean all parts with an approved cleaning solvent and dry thoroughly.
- (2) Inspect all parts for breaks, dents, and other damage. Replace damaged or defective parts as necessary.

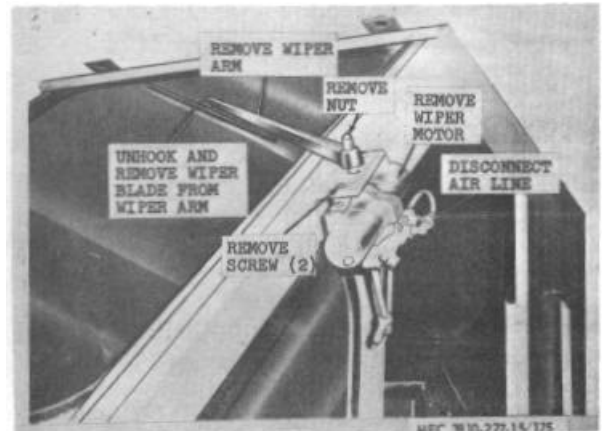

Figure 175. Crane Windshield wiper motor, and blade, removal and installation.

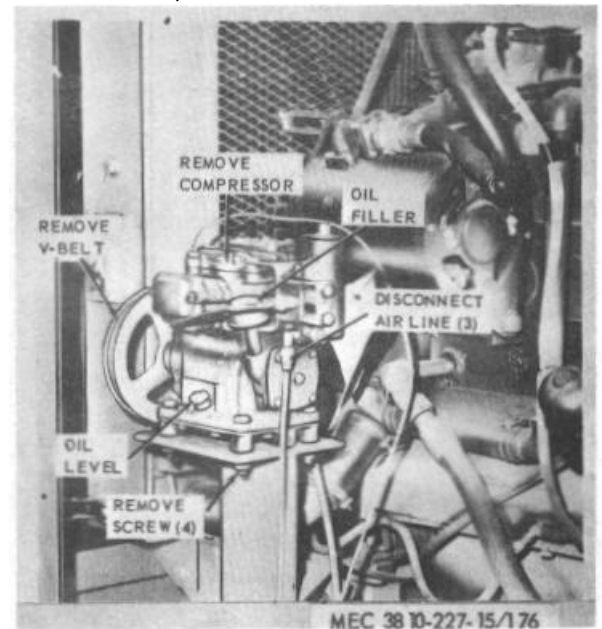

Figure 176. Crane engine air compressor, removal and installation.

### **283. Radiator Shutter**

*a. Removal and Installation.* Remove and install the radiator shutter as instructed on figure 174.

*b. Cleaning and Inspection.*

- (1) Clean the radiator shutter with an approved cleaning solvent and dry thoroughly.
- (2) Inspect the radiator shutter for breaks, bends, and other damage. Repair or replace damaged radiator shutter and mounting hardware as necessary.

### **284. Crane Windshield Wiper Blade**

*a. Inspection.* Inspect the crane windshield wiper blade for cracks, bends, and deterioration or cuts. Replace a defective wiper blade as necessary.

*b. Removal.* Remove the crane windshield wiper blade as illustrated on figure 175.

*c. Installation.* Install the crane windshield wiper blade as illustrated in figure 175.

### **285. Crane Windshield Wiper Motor**

*a. Removal.* Remove the windshield wiper motor as instructed on figure 175.

*b. Cleaning, Inspection, and Repair.*

- (1) Clean all parts with an approved cleaning solvent and dry thoroughly.
- (2) Inspect the windshield wiper motor for breaks, bends or other damage. Repair or replace damaged hardware.
- (3) Inspect the motor for proper operation. Replace a defective motor.

*c. Installation.* Install the windshield wiper motor as illustrated on figure 175.

### **286. Crane Engine Air Compressor**

*a. General.* The crane engine air compressor is mounted on a bracket below the generator and is V-belt driven from the engine. Its purpose is to supply air to operate the windshield wiper on the crane cab.

*b. Removal and Installation.* Remove and install compressor assembly as instructed on figure 176.

*c. Cleaning and Inspection.*

- (1) Clean the compressor with an approved cleaning solvent and dry thoroughly.
- (2) Inspect the compressor for cracks, breaks, and other damage.
- (3) Replace a defective or damaged compressor.

**CHAPTER 4**

**DIRECT AND GENERAL SUPPORT,  
AND DEPOT MAINTENANCE INSTRUCTIONS**

**Section I. REPAIR AND REPLACING STANDARDS**

**287. Repair and Replacement Standards**

Tables 3 and 4 list the manufacturer's sizes, tolerances, clearances, and allowable wear and clearance for the carrier and crane engine.

**Table 3. Crane Engine Repair and Replacement Standards**

	Manufacturer's dimensions and tolerances in inches		Desired clearance		Maximum allowable wear	Maximum allowable clearance
	Min.	Max.	Min.	Max.		
<b>CRANE ENGINE</b>						
Pistons						
Piston-to-cylinder clearance-----			0.004	0.006	0.0002	0.010
Piston pin hole in piston (dia)-----	1.2498	1.2501				
Ring groove width:						
1st-----	0.097	0.098				
2d and 3d-----	0.1265	0.1275				
4th-----	0.251	0.252				
Ring land dia:						
1st-----	4.216	4.220				
2d-----	4.220	4.224				
3d and 4th-----	4.226	4.229				
Skirt dia (perpendicular-to-pin bore)-----	4.245	4.247				
Piston Rings						
1st compression:					0.060	0.0055
Width-----	0.0925	0.0935	0.017	0.032		
Thickness-----	0.208	0.218	0.0035	0.0046		
Gap clearance-----						
Side clearance-----						
2d and 3d compression:						
Width-----	0.128	0.124				
Thickness-----	0.208	0.218				
Gap clearance-----			0.017	0.032		
Side clearance-----			0.0025	0.0035		
4th (oil) ring:					0.060	0.0045
Width-----	0.248	0.249				
Thickness-----	0.208	0.208				
Gap clearance-----			0.017	0.032		
Side clearance-----			0.002	0.004	0.060	0.006

AGO 6819A

**Table 3. Crane Engine Repair and Replacement Standards - Continued**

	Manufacturer's dimensions and tolerances in inches		Desired clearance		Maximum allowable wear	Maximum allowable clearance
	Min.	Max.	Min.	Max.		
<b>CRANE ENGINE-Continued</b>						
<b>Piston Pins</b>						
Length -----	3.620	3.625				
Pin dia -----	1.2498	1.2500				
Pin-to-piston clearance -----			0.0001	0.0002		0.0003
			(light push)			
Bushing id (finished)-----	1.2503	1.2506				
Bushing length-----	1.552	1.572				
Pin-to-bushing clearance-----			0.0003	0.0008		0.0025
<b>Connecting Rods</b>						
Length (center-to-center)-----	8.246	8.248				
Bushing hole dia-----	1.437	1.438				
Bushing od-----	1.442	1.444				
Bearing hole dia -----	2.7130	2.7135			0.003	
Bearing thickness-----	0.0748	0.0753				
Width at bearing end-----	1.6775	1.6795				
End play on crankshaft-----			0.006	0.010		0.015
<b>Crankshaft</b>						
Main journal dia -----	2.9985	2.9995			0.0040	
Main journal-to-main bearing clearance -----			0.0012		0.0030	0.0040
Crankshaft end play-----			0.005		0.008	0.010
Connecting rod journal-----	2.560	2.561			0.002	
Rod journal-to-rod bearing clearance-----			0.0014	0.0026		0.0040
Rod journal length -----	1.6855	1.6876				
<b>Camshaft</b>						
Journal dia (all) -----	2.242	2.243			0.002	
<b>Cam lift:</b>						
Intake-----	0.3395				0.0120	
Exhaust-----	0.3520				0.0120	
Camshaft bushing id -----	2.2445	2.2450			0.0020	
Camshaft-to-bushing clearance-----			0.0015	0.0030		0.0050
Camshaft end play-----			0.005	0.009		0.012
<b>Valves:</b>						
Valve length (overall)-----	6 1/16					
Stem dia-----	0.4335	0.4345			0.0020	
<b>Head dia:</b>						
Intake-----	1.995	2.005				
Exhaust-----	1.620	1.630				
Valve and seat angle-----	45°					
<b>Stem clearance:</b>						
Intake-----			0.0015	0.0035		0.0045
Exhaust-----			0.0045	0.0065		0.0075
<b>Valve Guides:</b>						
<b>Length:</b>						
Intake-----	2 13/16					
Exhaust-----	3 3/8					
<b>Outside dia:</b>						
Intake and exhaust-----	0.813	0.814				
<b>Inside dia:</b>						
Intake-----	0.4360	0.4370			0.0020	
Exhaust-----	0.4390	0.4400			0.0020	
<b>Valve seat face (top)-to-top of guide:</b>						
Intake-----	1 7/8					
Exhaust-----	1 5/16					

AGO 6819A

**Table 3. Crane Engine Repair and Replacement Standards - Continued**

	Manufacturer's dimensions and tolerances in inches		Desired clearance		Maximum allowable wear	Maximum allowable clearance
	Min.	Max.	Min.	Max.		
CRANE ENGINE-Continued						
Valve Springs						
Outside dia -----	1 5/16					
Wire size -----	0.172					
Spring length (valve closed) under load of ----- 51.3 to 58.3 lbs.	1.67					
Tension limit (min weight closed) -----						46.27 lbs
Spring length (valve open) ----- under load of 130 to 144 lbs.	1.226					
Tension limit (min weight open) -----						117 lbs
Crankcase						
Cylinder dia-----	4.249	4.251			0.008	
Main bearing bore in block-----	3.1913	3.1920				
Tappet hole dia-----	1.125	1.126				

**Table 4. Carrier Engine Repair and Replacement Standards**

	Manufacturer's dimensions and tolerances in inches		Desired clearance		Maximum allowable wear	Maximum allowable clearance
	Min.	Max.	Min.	Max.		
CARRIER ENGINE						
Pistons						
Piston-to-cylinder clearance-----				0.008		0.012
Piston pin hole dia -----	1.7499	1.7501			0.0004	
Pin-to-piston clearance -----			0.0001	0.0002		0.0004
Ring groove width:						
1st-----	0.097	0.098			0.003	
2d and 3d -----	0.1265	0.1275			0.003	
4th -----	0.2505	0.2515			0.003	
Ring land dia:						
1st-----	5.333	6.337				
2d -----	5.339	5.343				
3d -----	5.344	5.348				
4th -----	5.344	5.348				
Skirt Dia (perpendicular-to-pin bore)-----	5.367	5.369				
Piston Pins						
Length -----	4.524	4.539				
Diameter -----	1.7498	1.7500			0.0004	
Fit in piston -----			0.0001	0.0002		0.0003
Desired fit (piston heated)-----				Light push		
Bushing hole dia, fin-----	1.7503	1.7505			0.0030	
Clearance in bushing-----			0.0003	0.0007		0.0030
Length-bushing-----	1.927	1.947				
Piston Rings						
Ring width:						
1st-----	0.0925	0.0935			0.0030	
2d and 3d -----	0.123	0.124				
4th -----	0.248	0.249				

**Table 4. Carrier Engine Repair and Replacement Standards-Continued**

	Manufacturer's dimensions and tolerances in inches		Desired clearance		Maximum allowable wear	Maximum allowable clearance
	Min.	Max.	Min.	Max.		
<b>CARRIER ENGINE-Continued</b>						
Ring thickness:						
1st-----	0.208	0.218				
2d and 3d-----	0.208	0.218				
4th-----	0.208	0.218				
Ring gap clearance:						
1st-----			0.017	0.032		0.060
2d and 3d-----			0.017	0.032		0.060
4th-----			0.017	0.032		0.060
Ring side clearance:						
1st-----			0.0085	0.0065		0.0085
2d and 3d-----			0.0025	0.0046		0.0076
4th-----			0.0015	0.0086		0.0065
Connecting Rods						
Length, center-to-center-----	10.498	10.502				
Bushing hole dia-----	1.987	1.988				
Outside dia bushing-----	1.941	1.943				
Bearing hole dia-----	.69165	.6950				
Bearing thickness-----	0.0948	0.0958			0.0040	
Width at bearing end-----	2.426	2.428				
Side play-----			0.008	0.010		0.012
Main Bearings						
Shell thickness-----	0.1248	0.1263			0.0020	
Crankshaft						
Main journal dia-----	3.7490	3.7600			0.003	
Main journal-to-main bearing clearance-----			0.0020	0.0030		0.0046
Crankshaft end play-----			0.005	0.008		0.010
Crankpin dia-----	3.4990	3.5000			0.0030	
Crankpin-to-rod bearing clearance-----			0.0030			0.0040
Camshaft						
Camshaft end play-----			0.004	0.006		0.008
Bearing journal, dia-----	2.247	2.248			0.003	
Clearance, bearing-to-journals-----			0.015	0.0030		0.0050
Camshaft lift-----	0.374					
Cam bushing id-----	2.2495	2.2500			0.0030	
Tappets						
Tappet dia-----	0.6082	0.6087			0.0020	
Valve Guides						
Length:						
Intake-----	3.812					
Exhaust-----	4.125					
Outside diameter-----	0.8765					
Inside diameter-----	0.4985				0.003	
Wear limits max dia-----					0.5015	
Cylinder-head contact face-to-top of guide:						
Intake-----	1.531					
Exhaust-----	1.500					
Rocker Arms						
Bushing-----	0.968	0.969				
Clearance from shaft-to-bushing-----	0.0005	0.0015		0.001		

**Table 4. Carrier Engine Repair and Replacement Standards-Continued**

	Manufacturer's dimensions and tolerances in inches		Desired clearance		Maximum allowable wear	Maximum allowable clearance
	Min.	Max.	Min.	Max.		
<b>CARRIER ENGINE-Continued</b>						
Valves, Intake and Exhaust						
Overall length -----	7.25					
Stem dia:						
Intake-----	0.4965					
Exhaust-----	0.4966					
Head dia-----	2.245	2.255				
Seat angle -----	45°					
Angle of valve face-----	45°					
Stem clearance limit:						
Intake-----			0.002			0.0040
Exhaust-----			0.0035			0.0060
Valve Springs						
Outside diameter:						
Outer-----	1.8875	1.9075				
Inner-----	1.56S0	1.8750				
Wire gage:						
Outer-----	0.225					
Inner-----	0.172					
Spring length, valve closed:						
Outer-----	2 3/4					
Inner-----	2 19/82					
Spring load, valve closed:						
Outer-----	85-95					
	lbs					
Inner-----	41-49					
	lbs					
Wear limits, min wgt:						
Outer-----					77 lbs	
Inner-----					37 lbs	
Spring length, valve open:						
Outer-----	2 3/16					
Inner-----	2 1/32					
Spring load, valve open:						
Outer-----	192-208					
	lbs					
Inner-----	96-105					
	lbs					
Wear limit, min wgt:						
Outer-----					173 lb	
Inner-----					86 lbs	
Crankcase						
Cylinder dia-----	5.375	5.377			0.008	
Main bearing bore in block-----	4.002	4.003				
Tappet hole dia-----	0.6089	0.6101			0.0020	

**Section II. GENERAL SERVICING AND REPAIR INSTRUCTIONS**

**288. General**

This section contains general servicing and repair instructions that are common to similar items used in

different assemblies throughout the crane-shovel. Procedures for the removal, inspection, repair, and reassembly or installation of these items apply regardless



of the assembly. Slight modifications on the part of personnel should be made as necessary to facilitate the work on any particular item.

## 289. Bearings

*a. General.* Bearings, when required, must be maintained in proper condition to prevent wear and misalignment of moving parts on which they are installed.

*b. Removal.* Bearings are usually a press fit on a shaft but occasionally they may be pressed in the bore of a bearing housing. When removing or installing a bearing on a shaft, always apply the pressure on the inner race. When removing or installing in a bore, always apply pressure on the outer race. Do not transmit lateral pressures through the bearing from one race to another.

- (1) *Pressing.* Press bearings from shafts or out of housings whenever possible. Use firm, steady pressure and do not allow the bearing, shaft, or housing to drop on the floor or ground.
- (2) *Pulling.* Bearings may be pulled if a press is not available. The puller must be arranged to apply pressure on the retained race only.
- (3) *Driving.* Bearings can be removed by driving, using a soft drift carefully placed against the held race. Split pipe or tubing with welded lugs can be used to control application of the driving pressure. Alternate the blows on opposite sides of the race to prevent wedging the bearing. Be careful not to damage splines on the shaft or in the housing.

*c. Inspection and Repair.* Wipe off as much lubricant as possible. Agitate bearing in clean solvent, being careful not to spin the races. Remove bearing from solvent and flat-slap bearing against a wood block to remove solvent and shake loose any coagulated lubricant. Place bearing back in clean solvent and continue agitating until all traces of old lubricant is removed. When bearing is clean, remove it from the solvent, shake out as much as possible, and blow dry with compressed air directed across the races. As soon as the bearing is

dry, dip it in clean, light oil to prevent corrosion, and continued contact of unlubricated bearing surfaces. Drain off the excess oil and place bearing in a clean container or wrap until ready for inspection. The following defects cannot be rectified and require replacements of the bearings.

- (1) Rust spots on balls or races.
- (2) Worn or badly scored surfaces.
- (3) Cracked race.
- (4) Defective shield, seal, or separator.
- (5) Badly discolored balls or races caused by overheating.
- (6) Roughness.
- (7) Bearing catching at one or more points caused by damage not by dirt.
- (8) Excessive looseness or end play.

*d. Installation.* Clean shaft or housing before replacing a bearing. Pack the bearing with the proper lubricant. Install by pressing, the preferred method, or driving.

- (1) *Pressing.* Apply pressure on the held race only. When pressing on a shaft, support the bearing so that the inner race takes the pressure. When installing in a housing, apply pressure against outer race. Use a suitable mandrel and blocks so that pressure is applied evenly around the race.
- (2) *Driving.* When a press is not available, drive the bearing to its seat by using a soft drift against the held race. Alternate blows around the bearing to prevent cocking and possible wedging. Start bearing straight and be careful not to damage shaft or housing splines.
- (3) *Installation aids.* Coating a shaft with white lead before attempting to install parts will prevent binding and simplify installation. If necessary, heat a very tight fitting bearing to 250° F. in a clean oil bath. Always, dry and repack bearings that have been preheated.

AGO 6819A

## 290. Oil Seals

*a. General.* It is almost impossible to remove an oil seal without damaging it. Therefore, if a new seal is not immediately available, the old seal should be inspected in place.

*b. Removal.* Seals are removed by prying them out. They should then be discarded.

*c. Inspection.* Examine oil seals and discard if the following defects are observed; damaged case, worn sealing member, nicked sealing member, distorted inner diameter, or incorrectly seated seal.

*d. Installation.* New seals should always be inspected to assure that they are the right size. All burrs or sharp edges should be removed from the shaft to be sealed and the sealing element lubricated. The seal should be installed with the wiping edge of sealing element toward the lubricant or fluid to be sealed.

## 291. Bushings

*a. Removal and Installation.* When disassembling a unit the bushings should be removed with a puller or press whenever possible. This should be carefully done so as to not damage the bushings. When installing bushings, use a press or drive them in carefully so as to not batter or distort the edges. Align oil holes, if present, with oil holes in unit. Bushings should always fit tight in the housing, so there is no chance of their turning with the shaft. Be sure they are free of burrs and scratches.

*b. Cleaning and Inspection.* Clean bushings carefully and inspect for condition. As in the case of general overhaul it is advisable to replace bushings.

## 292. Shafts

A drift pin or block of wood should always be used to protect the end of a shaft when it requires hammering to drive it out or reinstall it. To avoid distortion and damage, never hammer directly on the end of any part.

## 293. Gears

*a. General.* The same procedures of inspection and repair apply to all gears used throughout the Crane-shovel.

*b. Inspection.* Examine gears for cracked, scored, chipped, or unevenly worn teeth. Examine the gear body for cracks and warpage. Inspect keyways for good condition.

*c. Repair.* Stone out small scored marks. Replace gears that have badly worn, chipped or broken teeth. Small body cracks can be repaired by welding and grinding. The heated area should be oil-quenched to maintain their heat treatment. Gear teeth or contact surfaces should be repaired by welding only if replacement parts are not available.

## 294. Shims

Shims are used to align and adjust bearings, bushings, gears, and shafts. Correct interaction of the machinery components requires the proper contact between parts, and this contact can be maintained only by shimming as the parts wear. When removing any part that is shimmed, mark carefully and tie the shims in their correct order for proper reassembly. If the shimming requirements of an assembly have changed, adjust the shims for the proper operation. Test run the unit after changing the shims to make certain that the shimming is correct before locking.

## 295. Brake and Clutch Linings

*a. General.* Brake and clutch linings should be replaced when they are worn to the point that lining rivets are flush with the surface. Any linings that are oil or grease soaked should also be replaced. Both halves of a paired lining should be replaced if one-half is worn or defective.

*b. Cleaning and Inspection.* If grease or oil is found between the lining and housing, take a clean cloth dampened with cleaning solvent and force it between the lining and housing at a point between the live and dead ends. Turn the machinery over several times. Remove the cloth and repeat the operation until the lining is thoroughly cleaned. If this procedure does not clean the lining, remove the band and lining and wash the lining thoroughly with solvent. Examine the lining for excessive wear, uneven wear, or signs of possible failure. Replace if necessary.

c. *Replacing Old Linings.* Support the band with the lining rivets to be removed lying over a hollow tube or pipe. Working from the band side, remove the rivets with a punch and, detach the lining from the band. Clamp a new piece of lining of the proper size, length, and thickness to the band. Using the band hole as a guide, drill lining holes with a hand drill. Countersink holes in lining to a depth of one-eighth inch less than the lining thickness. Rivet the lining to band with a rivet press or drift pin and rivet set, working from center of band out. The lining must bed perfectly on the band. Bevel the edges and ends of the lining with a file. Check all rivet heads to make certain that none will contact the drum. The band is then installed on the assembly and shaped.

d. *Shaping.* Shaping assures uniform clearance between lining and drum at all points. Proper shaping

gives most efficient braking or clutching action when the control lever is engaged.

- (1) Check band and drum for uneven clearances, Insert a flat wedge with smooth surfaces between lining and the drum at the point of drag. Operate the control lever and bend the band tightly over the wedge. If necessary, use a mallet to achieve additional shaping of the band to remove any high spots.
- (2) Breaking-in of a new lining can be speeded up by purposely slipping the band until it gets hot. Release the control lever and allow the band and lining to cool for at least 80 minutes before resuming operation.

### Section III. REMOVAL AND INSTALLATION OF MAJOR ITEMS

#### 296. Crane Cab Assembly

##### a. Removal.

- (1) Remove the crane boom attachment as necessary (para. 11).
- (2) Disconnect the control panel instruments and engine controls (para. 135).
- (3) Remove the crane cab assembly from the crane base as instructed on figure 177.

##### b. Installation.

- (1) Install the crane cab assembly as illustrated on figure 177.
- (2) Connect the control panel instruments and engine controls (para. 135).
- (3) Install the crane boom attachment as necessary (para. 11).

#### 297. Crane Engine Assembly

##### a. Removal.

- (1) Remove the crane cab (para. 296).
- (2) Drain the cooling system.
- (3) Disconnect the battery cables (para. 130).
- (4) Disconnect the fuel line (para. 92).

- (5) Disconnect the cab heater (para. 281).
- (6) Disconnect the master clutch linkage (para. 186).
- (7) Remove the primary drive chain case cover, drive chain, and drive gear (para. 196).
- (8) Remove the engine wiring harness (para. 316).
- (9) Remove the clutch assembly (para. 336).
- (10) Remove the crane engine assembly as instructed on figure 178.

##### b. Installation.

- (1) Install the crane engine assembly as illustrated on figure 178.
- (2) Install the clutch assembly (para. 338).
- (3) Install the engine wiring harness (para. 318).
- (4) Install the primary drive chain case cover, drive chain, and drive gear (para. 196).
- (5) Connect the master clutch linkage (para. 185).
- (6) Connect the cab heater (para. 281).
- (7) Connect the fuel line (para. 92).

AGO 6819A

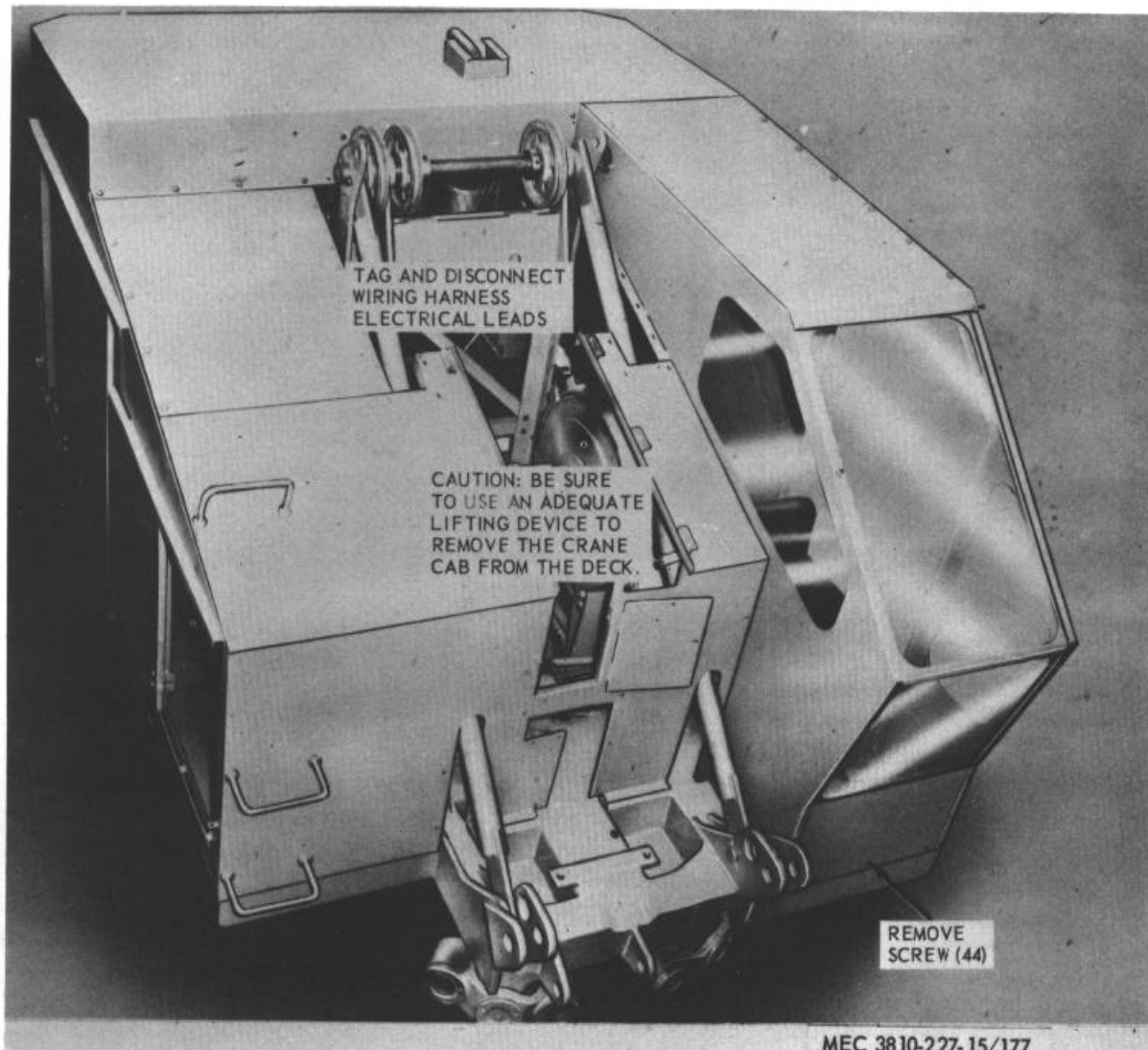

**Figure 177. Crane cab assembly, removal and installation.**

- (8) Connect the battery cables (para. 130).
- (9) Fill the cooling system.
- (10) Install the crane cab (para. 296).

**298. Carrier Engine Assembly**

*a. Removal.*

- (1) Drain the cooling system.
- (2) Remove the engine hood (para. 258).
- (3) Disconnect the battery cable (para. 103).
- (4) Disconnect the fuel line (para. 85).
- (5) Disconnect the clutch linkage (para. 245).

- (6) Disconnect the throttle linkage (para. 89).
- (7) Remove the hydraulic steering oil pump (para. 213).
- (8) Disconnect the engine wiring
- (9) Remove the air cleaner, duct, and shroud (paras. 84 and 147).
- (10) Remove the exhaust pipe and muffler (para. 168).
- (11) Disconnect the air compressor lines (para. 232).

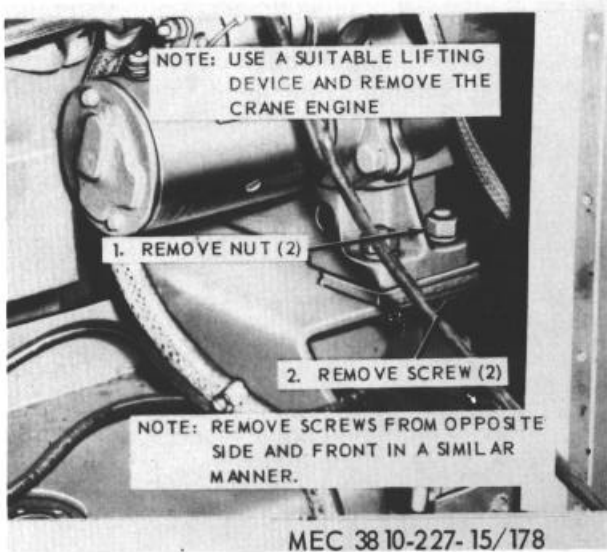
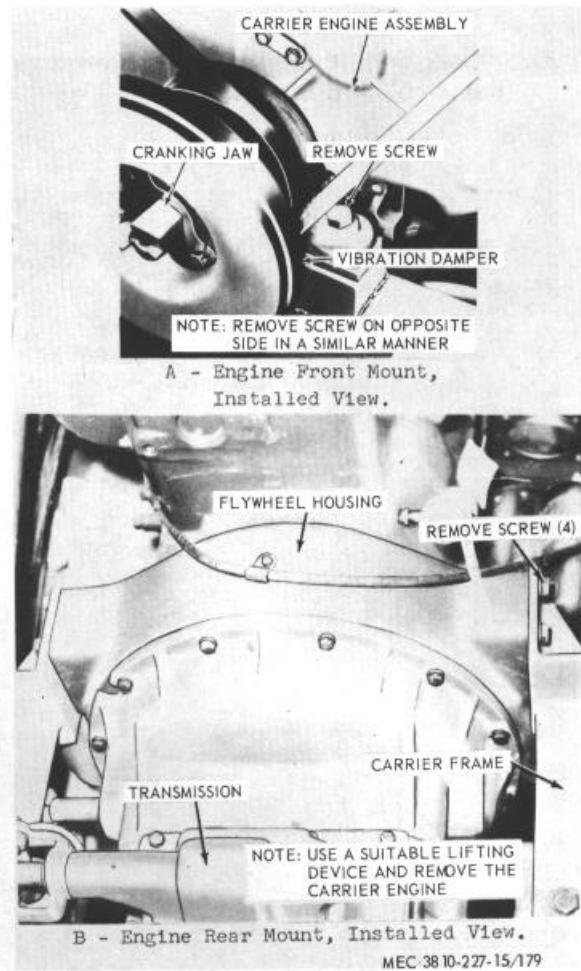

**Figure 178. Crane engine assembly, removal and installation.**

- (12) Disconnect the transmission housing control rods (para. 246).
- (13) Remove the transmission assembly (para. 471).
- (14) Remove the carrier engine assembly as instructed on figure 179.

**b. Installation.**

- (1) Install the carrier engine assembly as illustrated on figure 179.
- (2) Install the transmission assembly (para. 473).
- (3) Connect the transmission housing control rods (para. 245).
- (4) Connect the air compressor lines (para. 232).
- (5) Install the exhaust pipe and muffler (para. 168).
- (6) Install the air cleaner, duct, and shroud (paras. 84 and 147).
- (7) Connect the engine wiring.
- (8) Install the hydraulic steering oil pump (para. 213).



**Figure 179. Carrier engine assembly, removal and installation.**

- (9) Connect the throttle linkage (para. 89).
- (10) Connect the clutch linkage (para. 245).
- (11) Connect the fuel line (para. 85).
- (12) Connect the battery cables (para. 103).
- (13) Install the engine hood (para. 258).
- (14) Fill the cooling system.

**Section IV. CRANE ENGINE CARBURETOR ASSEMBLY**

**299. General**

An updraft-type carburetor is used on the crane engine. This side-intake, single-venturi carburetor is

sealed, protecting all internal parts from dirt and moisture. All air for fuel-air mixture and engine operation is drawn through the air cleaner.

**300. Crane Engine Carburetor Assembly Removal and Disassembly**

- a. *Removal.* Remove the carburetor (para. 93).
- b. *Disassembly.* Disassemble the carburetor in the numerical sequence as illustrated on figure 180.

**301. Crane Engine Carburetor Assembly Cleaning, Inspection and Repair**

- a. *Cleaning.* Clean all parts with an approved cleaning solvent.
- b. *Inspection and Repair.*
  - (1) Inspect all parts for cracks, bends, warpage, excessive wear, or other damage. Replace

all badly worn or damaged parts. Replace the gasket and seal.

- (2) Inspect the fuel valve and seat for scoring, pits, and excessive wear. If damaged or worn, replace as a set.

**302. Crane Engine Carburetor Assembly Reassembly and Installation**

- a. *Reassembly.* Reassemble the carburetor in the reverse of the numerical sequence as illustrated on figure 180.
- b. *Installation.* Install the carburetor assembly (para. 93).

**Section V. CRANE ENGINE GOVERNOR ASSEMBLY**

**303. General**

The crane engine governor assembly is a centrifugal, flyball-type. With this type of governor, it is the interaction of the two forces employed that achieves the regulation desired. The first is the centrifugal force developing in the balls inside the governor. This force is transferred to the carburetor throttle controls, tending to close the throttle as the speed of the engine increases. The second force is exerted by the governor spring and tends to hold the throttle wide open position. When these two forces are in balance, the engine is operating at the pre-set governor speed.

**304. Crane Engine Governor Assembly Removal and Disassembly**

- a. *Removal.* Remove the crane engine governor assembly from the engine (para. 94).
- b. *Disassembly.* Disassemble the crane engine governor assembly in the numerical sequence as illustrated on figure 181.

**305. Crane Engine Governor Assembly Cleaning, Inspection, and Repair**

- a. *Cleaning.* Clean all parts with an approved cleaning solvent.
- b. *Inspection and Repair.*
  - (1) Inspect all parts for excessive wear and other damage. Replace defective parts. Replace all gaskets.
  - (2) Inspect the ball driver on the governor shaft for possible need of replacement. If needed, heat the driver to remove brazing, and press the driver from the shaft. Press a new driver on the shaft and secure it by brazing.

**306. Crane Engine Governor Assembly, Reassembly and Installation**

- a. *Reassembly.* Reassemble the crane engine governor assembly in the reverse of the numerical sequence as illustrated on figure 181.
- b. *Installation.* Install the crane engine governor assembly on the engine (para. 94).

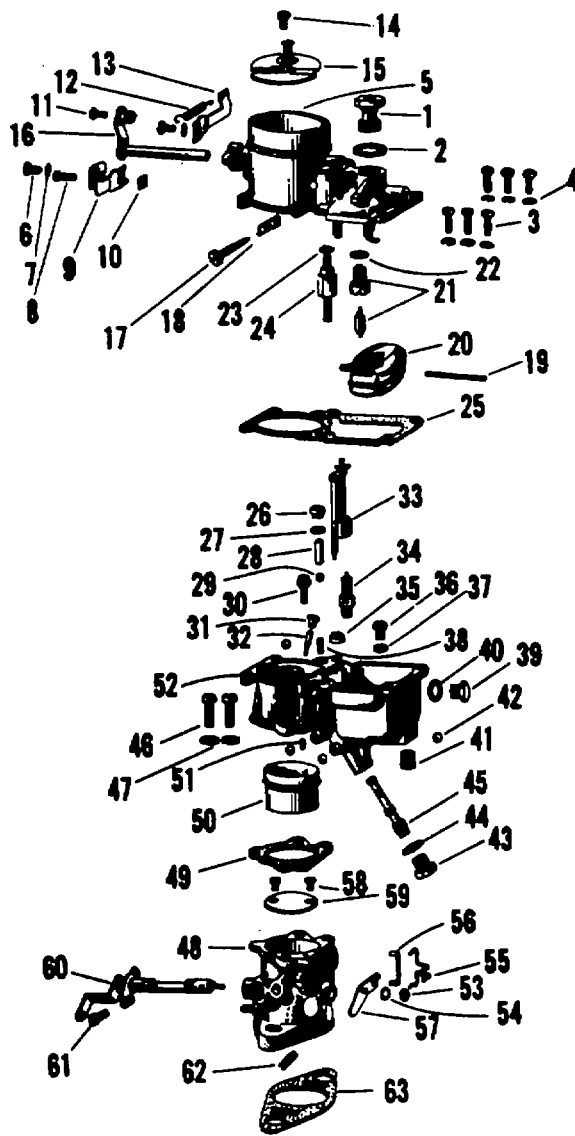

MEC 38 10-227-15/180

- |                       |                             |                         |                         |
|-----------------------|-----------------------------|-------------------------|-------------------------|
| 1 Plug                | 17 Idle adjust needle       | 33 Accelerating pump ay | 49 Gasket               |
| 2 Washer, fibre       | 18 Spring                   | 34 Power jet valve      | 50 Venturi              |
| 3 Screw               | 19 Float axle               | 35 Pump check valve     | 51 Idle channel bushing |
| 4 Lockwasher          | 20 Float                    | 36 Main jet             | 52 Fuel bowl            |
| 5 Air intake          | 21 Fuel valve needle & seat | 37 Washer, fibre        | 53 Nut                  |
| 6 Screw               | 22 Washer, fibre            | 38 Well vent jet        | 54 Lockwasher           |
| 7 Lockwasher          | 23 Washer, fibre            | 39 Plug, hex            | 55 Retainer, link       |
| 8 Screw               | 24 Vacuum cylinder          | 40 Washer, fibre        | 56 Link                 |
| 9 Bracket             | 25 Gasket                   | 41 Plug                 | 57 Pump lever           |
| 10 Nut                | 26 Air vent check valve     | 42 Plug                 | 58 Screw                |
| 11 Screw              | 27 Washer, retainer         | 43 Plug hex             | 59 Throttle plate       |
| 12 Spring             | 28 Weight                   | 44 Washer, fibre        | 60 Shaft & lever ay     |
| 13 Bracket            | 29 Check valve ball         | 45 Main discharge jet   | 61 Screw                |
| 14 Screw, choke plate | 30 Idle jet                 | 46 Screw                | 62 Vacuum passage screw |
| 15 Choke plate        | 31 Plug                     | 47 Lockwasher           | 63 Gasket               |
| 16 Lever & shaft ay   | 32 Idle jet                 | 48 Throttle body        |                         |

Figure 180. Crane engine carburetor assembly exploded view.

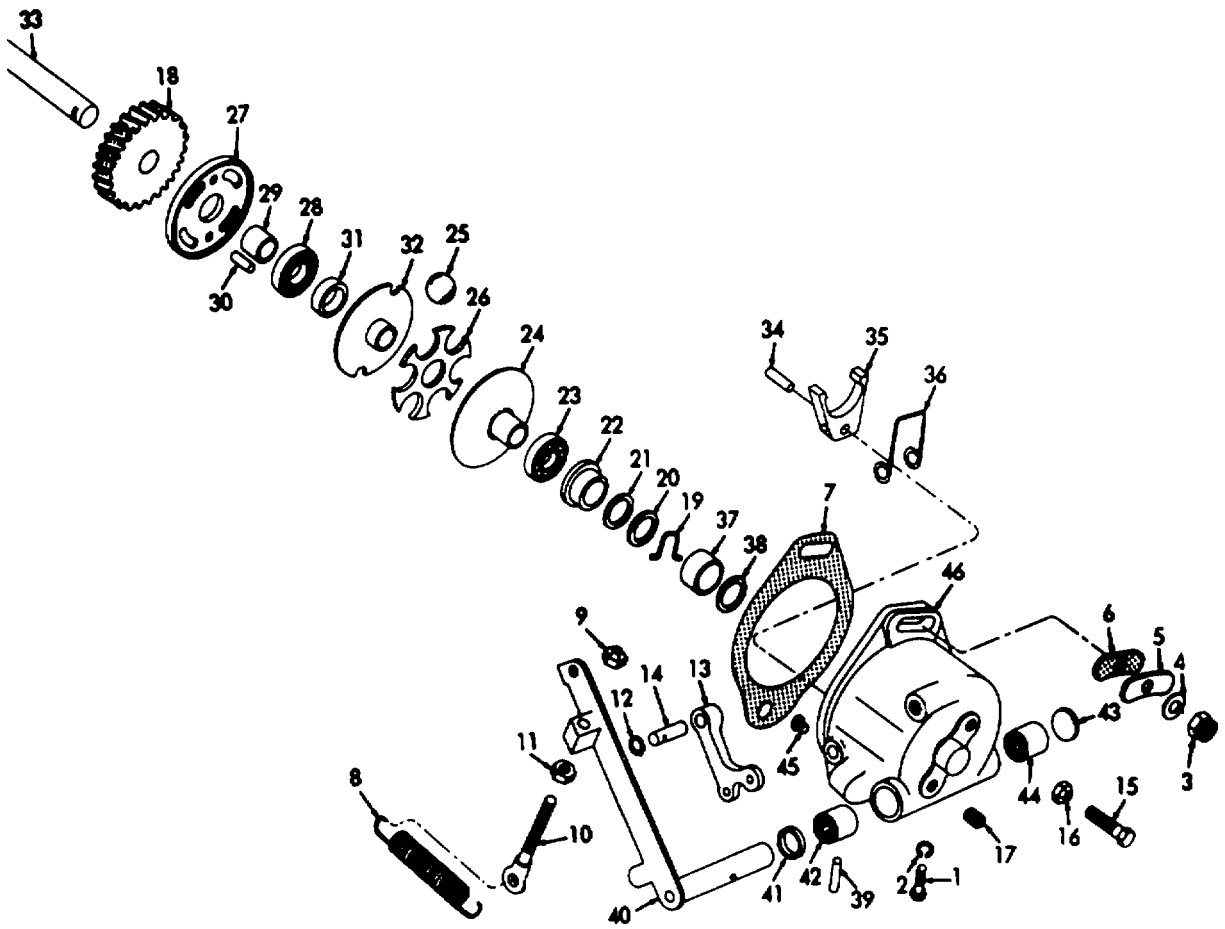

MEC 3810-227-15/181

- |                    |                     |                  |                   |
|--------------------|---------------------|------------------|-------------------|
| 1 Screw, cap       | 13 Control lever    | 25 Ball          | 37 Bushing        |
| 2 Washer, lock     | 14 Pin              | 26 Ball drive    | 38 Thrust washer  |
| 3 Nut              | 15 Adjusting screw  | 27 Base          | 39 Pin            |
| 4 Copper gasket    | 16 Locknut          | 28 Ball bearing  | 40 Governor lever |
| 5 Mounting plate   | 17 Pipe plug        | 29 Bushing       | 41 Oil seal       |
| 6 Gasket           | 18 Gear             | 30 Pin           | 42 Needle bearing |
| 7 Gasket           | 19 Clip             | 31 Thrust washer | 43 Expansion plug |
| 8 Governor spring  | 20 Flat washer      | 32 Lower race    | 44 Needle bearing |
| 9 Locknut          | 21 Ball stop washer | 33 Drive shaft   | 45 Locating screw |
| 10 Adjusting screw | 22 Fork base        | 34 Pin           | 46 Body           |
| 11 Locknut         | 23 Thrust bearing   | 35 Fork          |                   |
| 12 Retaining ring  | 24 Upper race       | 36 Bumper spring |                   |

Figure 181. Crane engine governor assembly, exploded view.

## Section VI. CRANE ENGINE FUEL TANK

### 307. General

The crane engine fuel tank is a 50 gallon, steel constructed tank, mounted at the rear side of the cab underneath the engine.

### 308. Crane Engine Fuel Tank Removal

- a. Drain the crane engine fuel tank.
- b. Remove the fuel lines (para. 92).

AGO 6819A



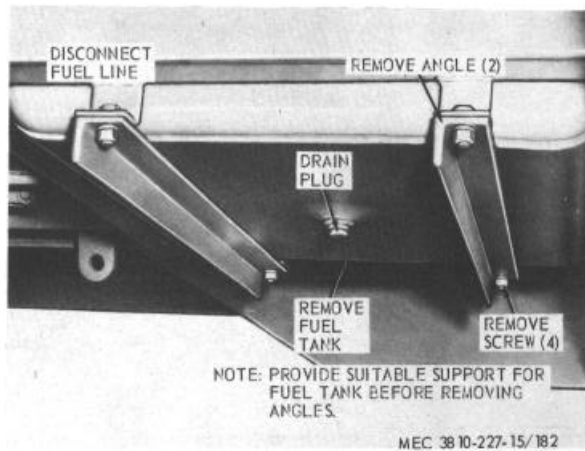

**Figure 182. Crane engine fuel tank, removal and installation.**

c. Remove the crane engine fuel tank as instructed on figure 182.

### 309. Crane Engine Fuel Tank Cleaning, Inspection and Repair

a. *Cleaning.* Clean the fuel tank with live steam. Dry thoroughly.

b. *Inspection and Repair.*

- (1) Inspect the fuel tank for rust, small leaks, cracks, and other damage.
- (2) To locate leaks, fill the tank with water with all but one outlet closed or plugged. Apply 3 to 5 psi of air pressure to the tank. Turn leak uppermost and repair by welding. Test again for leaks.

#### **Warning**

**Be sure tank is completely filled with water to prevent fumes from gathering and causing an explosion.**

- (3) Remove the fuel cap slowly until the air pressure is relieved.
- (4) Drain the water from the tank. Dry thoroughly.
- (5) Replace or repair a defective tank.

### 310. Crane Engine Fuel Tank Installation

a. Install the crane engine fuel tank under the engine in the reverse of the instructions on figure 182.

b. Install the fuel lines (para. 92).

c. Fill the crane engine fuel tank.

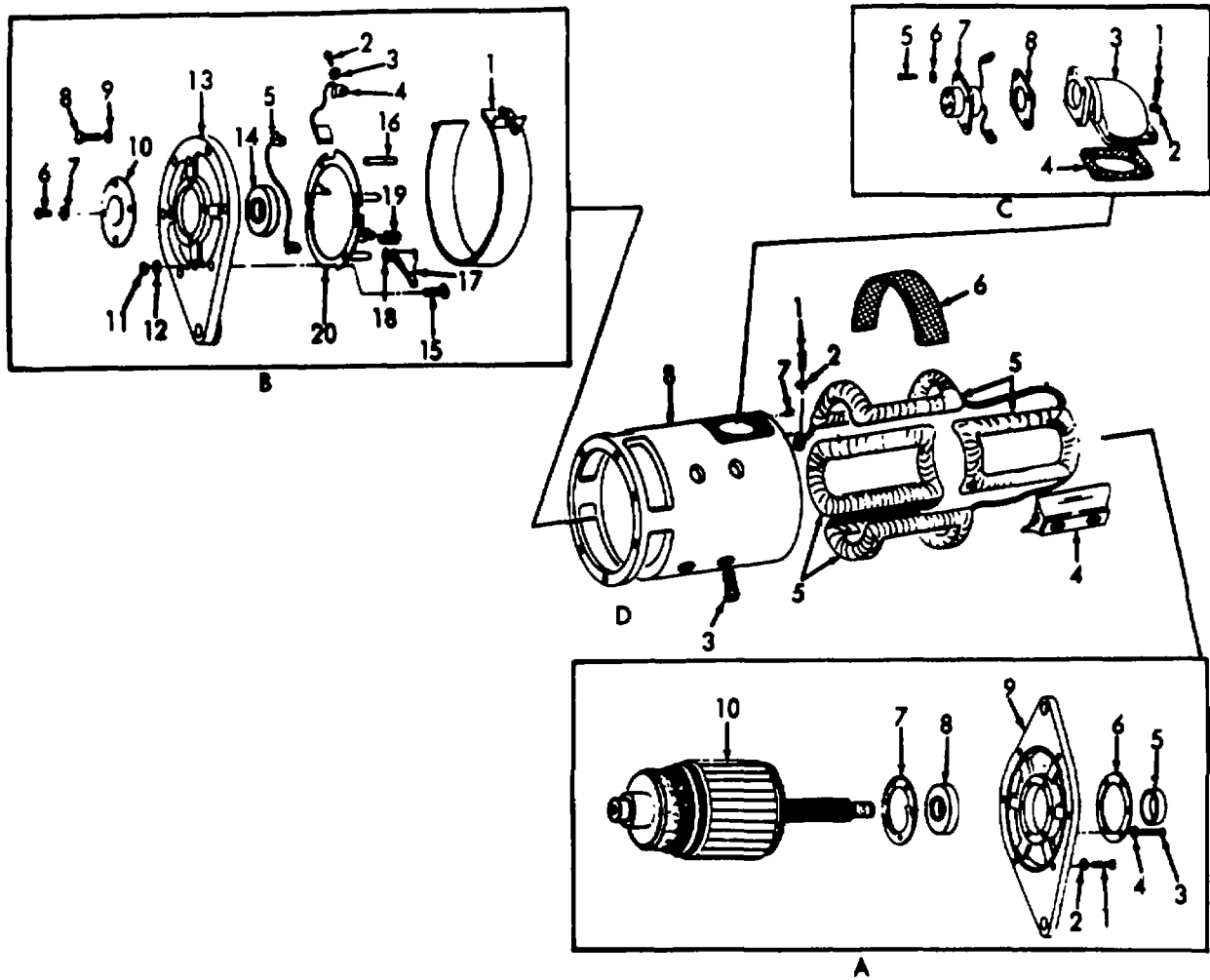

MEC 3810-227-15/183

- |                |                             |
|----------------|-----------------------------|
| 1 Screw, cap   | 6 Retaining plate, external |
| 2 Washer, lock | 7 Retaining plate, internal |
| 3 Screw        | 8 Bearing, sealed           |
| 4 Washer, lock | 9 Drive end frame           |
| 5 Collar       | 10 Armature                 |

A—Armature and drive end frame

- |                |                       |
|----------------|-----------------------|
| 1 Screw        | 5 Screw               |
| 2 Washer, lock | 6 Washer, lock        |
| 3 Elbow        | 7 Terminal receptacle |
| 4 Gasket       | 8 Spacer block        |

C—Outlet receptacle

- |                       |                         |
|-----------------------|-------------------------|
| 1 Cover band assembly | 11 Nut                  |
| 2 Screw               | 12 Washer, lock         |
| 3 Washer, lock        | 13 Commutator end plate |
| 4 Brush               | 14 Bearing, sealed      |
| 5 Lead assembly       | 15 Screw, special       |
| 6 Screw               | 16 Dowel pin            |
| 7 Washer, lock        | 17 Brush arm            |
| 8 Screw, cap          | 18 Spacer washer        |
| 9 Washer, lock        | 19 Spring               |
| 10 End cover plate    | 20 Brush plate assembly |

B—Commutator end frame and brushes

- |                   |                    |
|-------------------|--------------------|
| 1 Screw           | 5 Field coil       |
| 2 Washer, lock    | 6 Insulation band  |
| 3 Pole shoe screw | 7 Dowel pin        |
| 4 Pole shoe       | 8 Field coil frame |

D—Field coils, field coil frame, and pole shoes

Figure 183. Crane engine generator assembly, exploded view.

## Section VII. CRANE ENGINE GENERATOR ASSEMBLY

### 311. General

The crane engine generator assembly is a 4-pole, shunt-type unit with sealed ball bearings in both the drive end frame and the commutator end frame. The generator serves a dual purpose: it supplies electrical energy for lights, ignition, and accessories, and it serves to recharge the batteries by furnishing current to make up for cranking and other power supplied by the batteries while the generator is not in operation. The armature rotates between the field coils and produces voltage. The generator is cooled by a fan mounted on the drive pulley. The generated current is discharged to the electrical system through the armature and field terminals. The generator rotates clockwise with a brush tension of 28 ounces. The field current at 808 Fahrenheit is 1.00-105 amperes at 24 volts. The cold output of the generator at 4000 revolutions per minute is 40 amperes at 28 volts.

### 312. Crane Engine Generator Assembly Removal and Disassembly

- a. *Removal.* Remove the crane engine generator

assembly from the crane engine assembly (para. 132).

- b. *Disassembly.* Disassemble the crane engine generator assembly in the numerical sequence as illustrated on figure 188.

### 313. Crane Engine Generator Assembly Cleaning, Inspection and Repair

- a. *Cleaning.* Clean all parts with an approved cleaning solvent.

- b. *Inspection and Repair.* Inspect all parts for excessive wear or other damage. Repair or replace all defective parts. Refer to TM 5-764 for armature and field coil tests.

### 314. Crane Engine Generator Assembly Reassembly and Installation

- a. *Reassembly.* Reassemble the crane engine generator assembly in the reverse of the numerical sequence as illustrated on figure 183.

- b. *Installation.* Install the crane engine generator assembly on the crane engine assembly (para. 132).

## Section VIII. CRANE INSTRUMENT PANEL AND WIRING HARNESS

### 315. General

The crane instrument panel is located on the right side of the crane cab and contains the necessary gages, instruments, and wiring for proper operation of the crane engine.

### 316. Crane Instruments Panel and Wiring Harness Removal

- a. Remove the instrument panel component (para. 135).

- b. Remove the instrument panel and wiring harness as instructed on figure 184.

### 317. Crane Instrument Panel and Wiring Harness Cleaning and Inspection

- a. *Cleaning.* Clean the instrument panel with

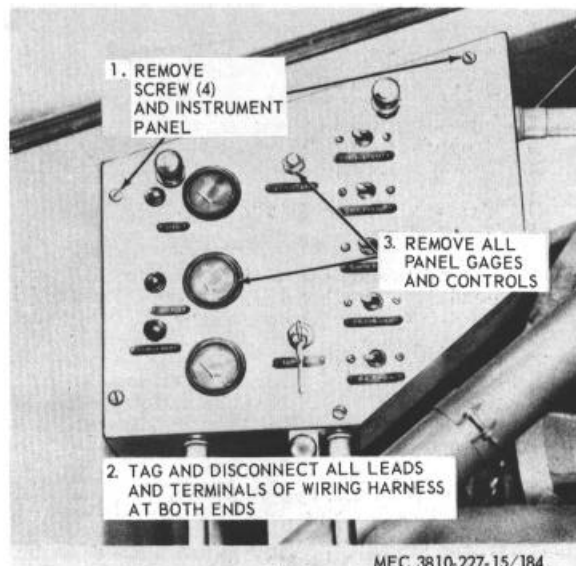
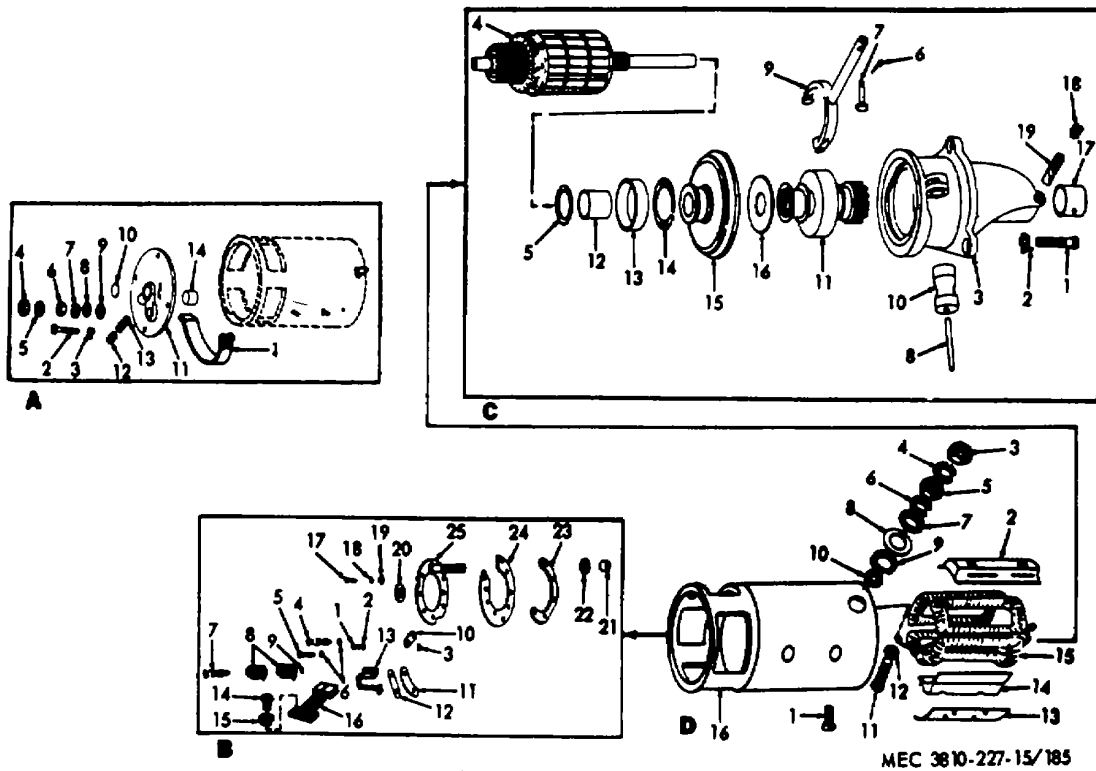

Figure 184. Crane instrument panel and wiring harness, removal and installation.

AGO 6819A



- |                         |                           |
|-------------------------|---------------------------|
| 1 Cover band            | 9 Insulating Washer       |
| 2 Screw, cap            | 10 End frame plug         |
| 8 Washer, lock, special | 11 Commutator end frame   |
| 4 Nut                   | 12 Commutator end plug    |
| 5 Washer, lock          | 13 Commutator end wick    |
| 6 Nut                   | 14 Commutator end bushing |
| 7 Washer, lock          |                           |
| 8 Washer, flat          |                           |

A—Commutator and frame

- |  |                                  |
|--|----------------------------------|
| 1 Screw, machine                           | 9 Insulating washer              |
| 2 Washer, lock                             | 10 Insulating bushing            |
| 3 Insulating washer                        | 11 Insulating washer             |
| 4 Ground brush holder screw                | 12 Insulating brush holder plate |
| 5 Screw, machine                           | 13 Insulating brush holder plate |
| 6 Washer, lock                             | 14 Brush holder                  |
| 7 Insulating brush holder screw            | 15 Screw, machine                |
| 8 Brush spring                             | 16 Washer, lock                  |
| 9 Washer, lock                             | 17 Brush                         |
| 10 Ground brush spacer plate               | 18 Screw, machine                |
| 11 Insulating brush holder plate           | 19 Washer, lock                  |
| 12 Insulating brush holder plate           | 20 Washer, flat                  |
| 13 Brush holder                            | 21 Commutator end spacer washer  |
| 14 Screw, machine                          | 22 Insulating bushing            |
| 15 Washer, lock                            | 23 Insulating washer             |
| 16 Brush                                   | 24 Brush holder attaching plate  |
| 17 Screw, machine                          | 25 Insulating brush plate        |
| 18 Washer, lock                            |                                  |
| 19 Washer, flat                            |                                  |
| 20 Commutator end spacer washer            |                                  |
| 21 Insulating bushing                      |                                  |
| 22 Insulating washer                       |                                  |
| 23 Insulating brush holder attaching plate |                                  |
| 24 Insulating brush plate                  |                                  |
| 25 Brush plate stud                        |                                  |

B—Brush plate, holders, and brushes

- |                          |                           |
|--------------------------|---------------------------|
| 1 Screw, machine         | 10 Shift shaft            |
| 2 Washer, lock, special  | 11 Drive assembly         |
| 3 Drive housing          | 12 Center bearing bushing |
| 4 Armature               | 13 Wick retainer ring     |
| 5 Armature spacer washer | 14 Center bearing wick    |
| 6 Pin, cotter            | 15 Center bearing         |
| 7 Pin                    | 16 Brake washer           |
| 8 Dowel pin              | 17 Bushing                |
| 9 Shift lever            | 18 End plug               |
| 10 Shift shaft           | 19 Oil wick               |

MEC 3810-227-15/185

C—Armature and drive housing

- |                          |
|--------------------------|
| 1 Pole shoe screw        |
| 2 Pole shoe              |
| 3 Nut                    |
| 4 Washer, lock           |
| 5 Nut                    |
| 6 Washer, lock           |
| 7 Washer, flat           |
| 8 Insulating washer      |
| 9 Insulating washer      |
| 10 Insulating bushing    |
| 11 Terminal stud         |
| 12 Insulating washer     |
| 13 Coil insulating strip |
| 14 Pole shoe             |
| 15 Field coil assembly   |
| 16 Field frame           |

D—Pole shoes, field coil and frame assembly

Figure 185. Crane engine starter assembly, exploded view.

an approved cleaning solvent and dry thoroughly. Clean the wiring harness with a lintfree dry cloth.

*b. Inspection.* Inspect all parts for excessive wear or damage. Replace all damaged or defective parts.

### **318. Crane Instrument Panel and Wiring Harness Installation**

*a.* Install the crane instrument panel and wiring harness as illustrated on figure 184.

*b.* Install the instrument panel component (para. 135).

## **Section IX. CRANE ENGINE STARTER ASSEMBLY**

### **319. General**

The crane engine starter assembly is a heavy duty type with over-running clutch-type drive. The starter turns at 6,000 rpm, drawing 23.4 volts at 30 maximum amperes with no load, and develops 20 foot pounds torque, drawing 6.6 volts at 200 maximum amperes when locked. The starting motor has four poles using eight brushes and has an intermediate bearing to support the armature shaft in the middle, while the ends are supported by bushings.

### **320. Crane Engine Starter Assembly Removal and Disassembly**

*a. Removal.* Remove the starter (para. 129).

*b. Disassembly.* Disassemble the starter in numerical sequence as illustrated on figure 185.

### **321. Crane Engine Starter Assembly Cleaning, Inspection and Repair**

*a. Cleaning.* Clean all parts with an approved cleaning solvent and dry thoroughly.

*b. Inspection and Repair.* Inspect all parts for excessive wear or damage. Replace or repair all defective parts. Refer to TM 5-764 for armature and field coil tests.

### **322. Crane Engine Starter Assembly Reassembly and Installation**

*a. Reassembly.* Reassemble the starter in the reverse of the numerical sequence as illustrated on figure 185.

*b. Installation.* Install the starter (para. 129).

## **Section X. CRANE ENGINE DISTRIBUTOR ASSEMBLY**

### **323. General**

The crane engine distributor assembly is a 24-volt grounded type distributor. The distributor is radio suppressed through a built-in system consisting of a primary connection capacitor, an ignition coil capacitor, and resistors at each high tension outlet of the distributor cap, as well as one built into the rotor. The primary terminal inlet is set at an angle to the distributor housing, to prevent mounting space.

### **324. Crane Engine Distributor Assembly Removal and Disassembly**

*a. Removal.* Remove the distributor (para. 125).

*b. Disassembly.* Disassemble the distributor in numerical sequence as illustrated on figure 186.

### **325. Crane Engine Distributor Assembly Cleaning, Inspection, and Repair**

*a. Cleaning.* Clean all parts with a dry, lint free cloth and compressed air.

*b. Inspection and Repair.* Inspect all parts for excessive wear or damage. Replace or repair all defective parts.

### **326. Crane Engine Distributor Assembly Reassembly and Installation**

*a. Reassembly.* Reassemble the distributor in the reverse of the numerical sequence as illustrated on figure 186.

*b. Installation.* Install the distributor (para. 125).

AGO 6819A

## Section XI. CRANE ENGINE RADIATOR ASSEMBLY

### 327. General

The crane engine radiator assembly is a one-piece core unit mounted on the front engine support. Coolant is circulated from the coolant pump to the radiator where it is cooled, and then recirculated through the coolant passages.

### 328. Crane Engine Radiator Assembly Removal

- a. Drain the radiator.
- b. Disconnect radiator hoses (para. 153).
- c. Remove fan guard and shroud (para. 156).
- d. Remove the radiator as instructed on figure 187.

### 329. Crane Engine Radiator Assembly Cleaning, Inspection and Repair

- a. Flush the inside of the radiator with an approved cleaning solvent. Avoid high pressure so as not to damage the radiator core.
- b. Clean the radiator core with compressed air or water under pressure from the fan side of the core.

- c. Clean the overflow line with compressed air.
- d. Plug all openings in the radiator.
- e. Insert air hose in radiator outlet pipe and caulk around the base.
- f. Immerse the radiator in water and apply 5 psi air pressure to the radiator.
- g. Watch for signs of air bubbles.
- h. Remove the radiator from the water and disconnect air hose.
- i. Replace or repair a damaged or defective radiator.

### 330. Crane Engine Radiator Assembly Installation

- a. Install the radiator as illustrated on figure 187.
- b. Install fan guard and shroud (para. 156).
- c. Connect the radiator hoses. (para. 153).
- d. Fill the radiator.

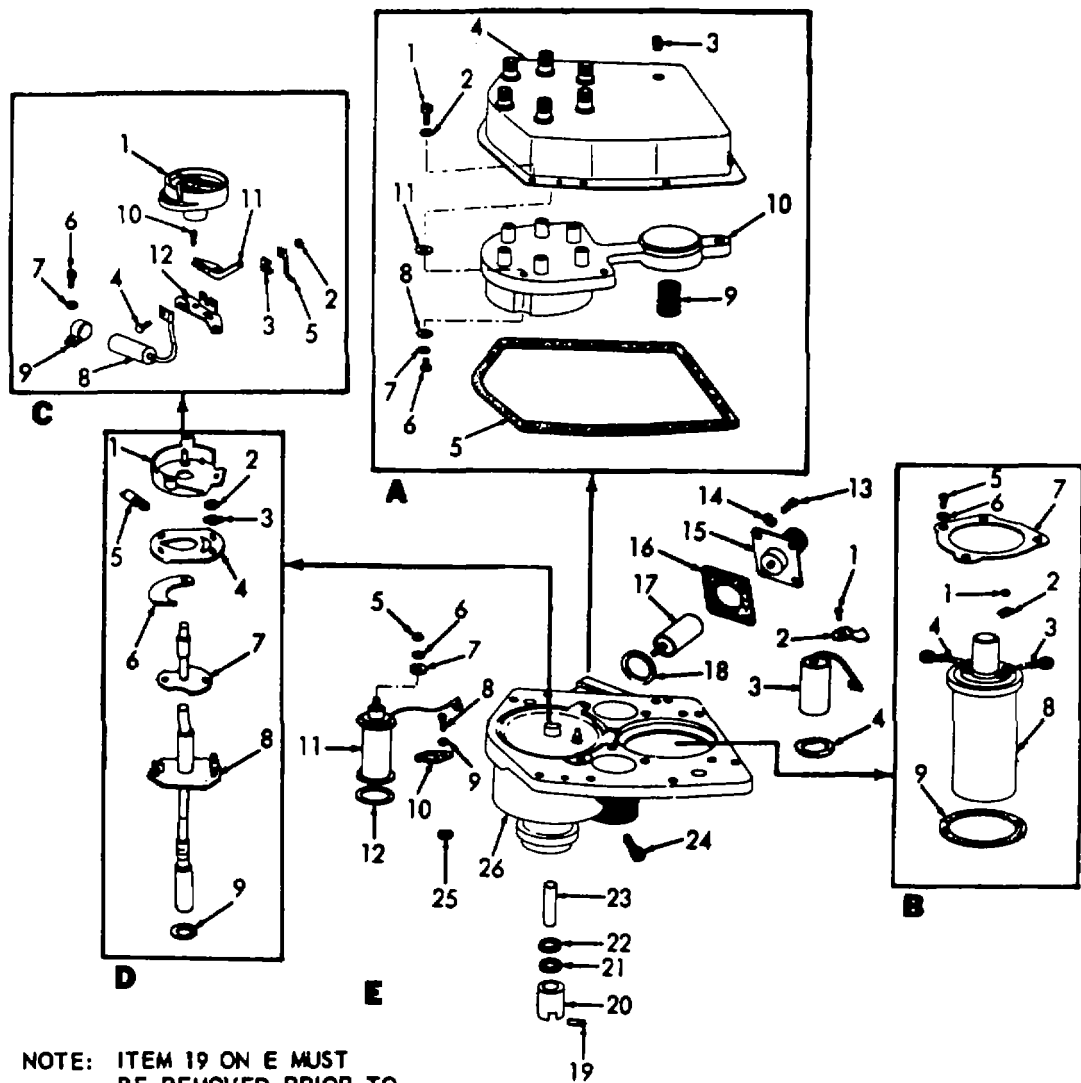

NOTE: ITEM 19 ON E MUST BE REMOVED PRIOR TO ITEM 8 ON D.

MEC 3810-227-15/186

- |                |                    |                 |                              |
|----------------|--------------------|-----------------|------------------------------|
| 1 Screw        | 7 Washer, lock     | 1 Rotor         | 7 Washer, lock               |
| 2 Washer, lock | 8 Washer, flat     | 2 Nut           | 8 Condenser                  |
| 3 Plug         | 9 Spring           | 3 Lock, special | 9 Bracket                    |
| 4 Cover        | 10 Distributor cap | 4 Screw, cap    | 10 Screw                     |
| 5 Gasket       | 11 Gasket          | 5 Jumper wire   | 11 Breaker point             |
| 6 Screw        |                    | 6 Screw         | 12 Contact and support point |

A—Distributor cap

C—Rotor and points

- |                       |          |                 |                                  |
|-----------------------|----------|-----------------|----------------------------------|
| 1 Nut                 | 6 Washer | 1 Breaker plate | 6 Weight                         |
| 2 Lock, special       | 7 Plate  | 2 Nut           | 7 Cam                            |
| 3 Coil condenser wire | 8 Coil   | 3 Lockplate     | 8 Shaft and weight base assembly |
| 4 Jumper wire         | 9 Gasket | 4 Cover         | 9 Thrust washer                  |
| 5 Screw               |          | 5 Weight spring |                                  |

B—Ignition coil

D—Breaker plate and weight base assembly

Figure 186. Crane engine distributor assembly, exploded view.

AGO 6819A

- 1 Screw
- 2 Lock, special
- 3 Ignition coil condenser
- 4 Spring
- 6 Nut
- 6 Washer, lock
- 7 Washer, flat
- 8 Screw
- 9 Washer, lock

- 10 Bracket
- 11 Resistor
- 12 Spring
- 13 Screw
- 14 Washer, lock
- 15 Terminal coupling
- 16 Gasket
- 17 Condenser
- 18 Spring

- 19 Pin
- 20 Coupling
- 21 Shim, 0.06 in.
- 22 Shim, 0.10 in.
- 23 Sleeve bearing
- 24 Breather
- 26 Plug
- 26 Distributor housing

E - Distributor housing, resistor, and condenser

**Figure 186-Continued.**

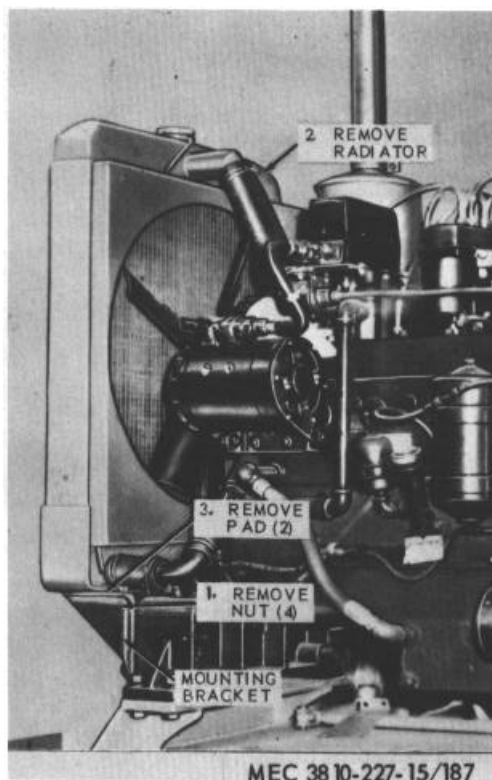

**Figure 187. Crane engine radiator assembly, removal and installation.**

**Section XII. CRANE ENGINE WATER PUMP ASSEMBLY**

**331. General**

The crane engine water pump assembly is an impeller-type pump. The pump, which is belt driven from the crankshaft, incorporates a carbon-type shaft seal with a

spring-loaded bellows for proper tension. The total pump output of hot water from the engine block is circulated through the radiator and then returned to the lower engine block to complete the cooling water cycle.

AGO 6819A



**332. Crone Engine Water Pump Assembly Removal and Disassembly**

- a. *Removal.* Remove the water pump (para. 158).
- b. *Disassembly.* Disassemble the water pump in numerical sequence as illustrated on figure 188.

**333. Crane Engine Water Pump Assembly Cleaning, Inspection and Repair**

- a. *Cleaning.* Clean all parts with an approved cleaning solvent and dry thoroughly.

- b. *Inspection and Repair.* Inspect all parts for excessive wear or damage. Replace or repair all defective parts.

**334. Crone Engine Water Pump Assembly Reassembly and Installation**

- a. *Reassembly.* Reassemble the water pump in the reverse of the numerical sequence as illustrated on figure 188.
- b. *Installation.* Install the water pump (para. 158).

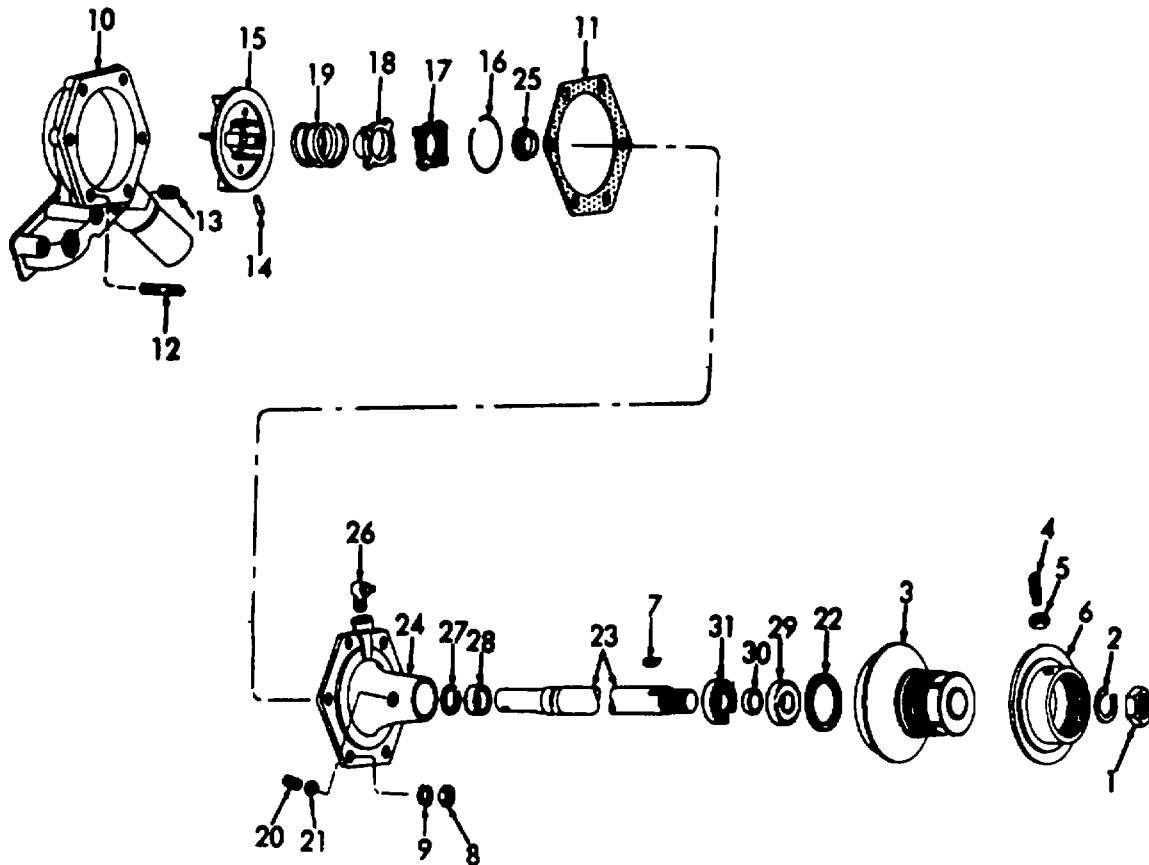

MEC 3810-227-15/188

- |                     |                |                 |                 |
|---------------------|----------------|-----------------|-----------------|
| 1 Nut               | 9 Washer, lock | 17 Carbon seal  | 25 Bushing      |
| 2 Washer, lock      | 10 Body        | 18 Bellows seal | 26 Fitting      |
| 3 Fan hub           | 11 Gasket      | 19 Seal spring  | 27 Snap ring    |
| 4 Screw             | 12 Stud        | 20 Screw        | 28 Retainer     |
| 5 Nut               | 13 Plug        | 21 Nut          | 29 Ball bearing |
| 6 Adjustable flange | 14 Pin         | 22 Seal         | 30 Spacer       |
| 7 Key               | 15 Impeller    | 23 Shaft        | 31 Ball bearing |
| 8 Nut               | 16 Snap Ring   | 24 Support      |                 |

Figure 188. Crane engine water pump assembly, exploded view.

AGO 6819A

### Section XIII. CRANE ENGINE CLUTCH ASSEMBLY

#### 335. General

The crane engine is equipped with a friction-type twin-disk clutch assembly that is enclosed within its own housing and is bolted to the engine fly wheel housing. Engagement and disengagement of the clutch is by lever. The friction plate is engaged by splines into a driving plate bolted to the flywheel.

#### 336. Crane Engine Clutch Assembly Removal and Disassembly

##### a. Removal.

(1) Remove the primary drive chain case cover, drain chain, and drive gear (para. 196).

(2) Remove the engine clutch assembly as instructed on figure 189.

b. Disassembly. Disassemble the engine clutch assembly in numerical sequence as illustrated on figure 190.

#### 337. Crane Engine Clutch Assembly Cleaning, Inspection, and Repair

a. *Cleaning.* Clean all parts with an approved cleaning solvent and dry thoroughly.

b. *Inspection and Repair.* Inspect drive plate segments for heat discoloration. Inspect all parts for excessive wear and damage. Check and play for proper clearance of 0.004 to 0.007 inch. Replace or repair all defective parts.

#### 338. Crane Engine Clutch Assembly Reassembly and Installation

a. *Reassembly.* Reassemble the engine clutch assembly in the reverse of the numerical sequence as illustrated on figure 190.

##### b. Installation.

(1) Install the engine clutch assembly as illustrated on figure 189.

(2) Install the primary drive chain case cover, drive chain, and drive gear (para. 196).

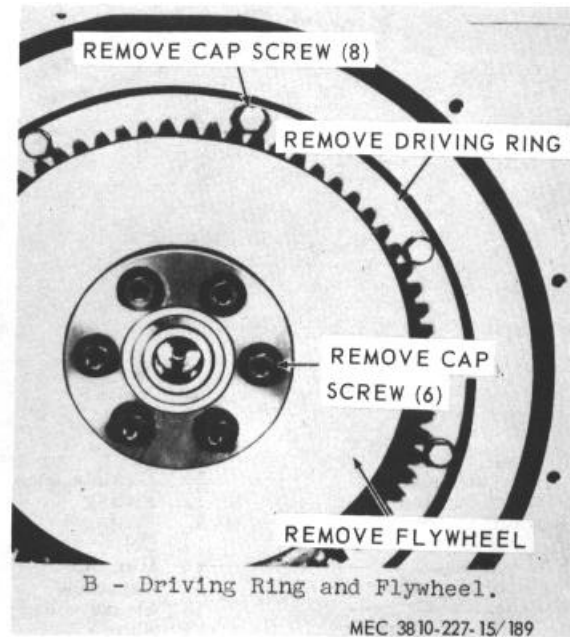
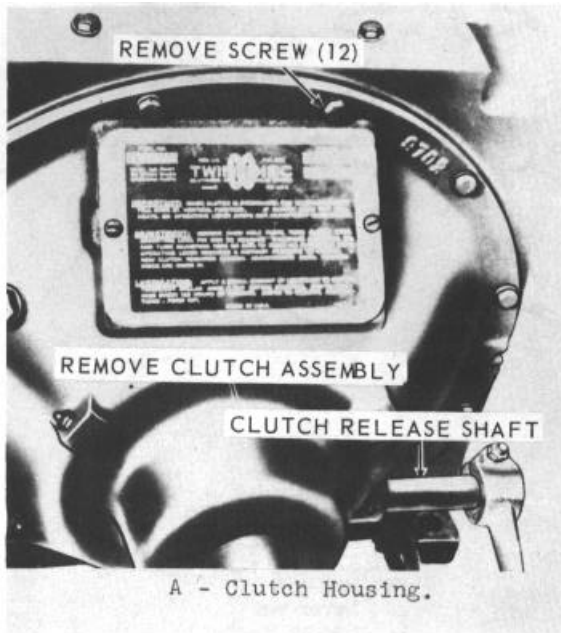

Figure 189. Crane engine clutch assembly, removal and installation.

## Section XIV. CRANE ENGINE CYLINDER HEAD ASSEMBLY AND VALVES

### 339. General

The crane engine cylinder head is of the L-head type. The spark plugs are mounted in the cylinder head.

### 340. Crane Engine Cylinder Head Removal

- a. Drain the cooling system.
- b. Remove the generator regulator (para. 134).
- c. Remove the spark plugs (para. 127).
- d. Remove the distributor (para. 125).
- e. Remove the radiator hose (para. 153).
- f. Remove thermostat and housing assembly (para. 155).
- g. Remove cylinder head as instructed in figure 191.

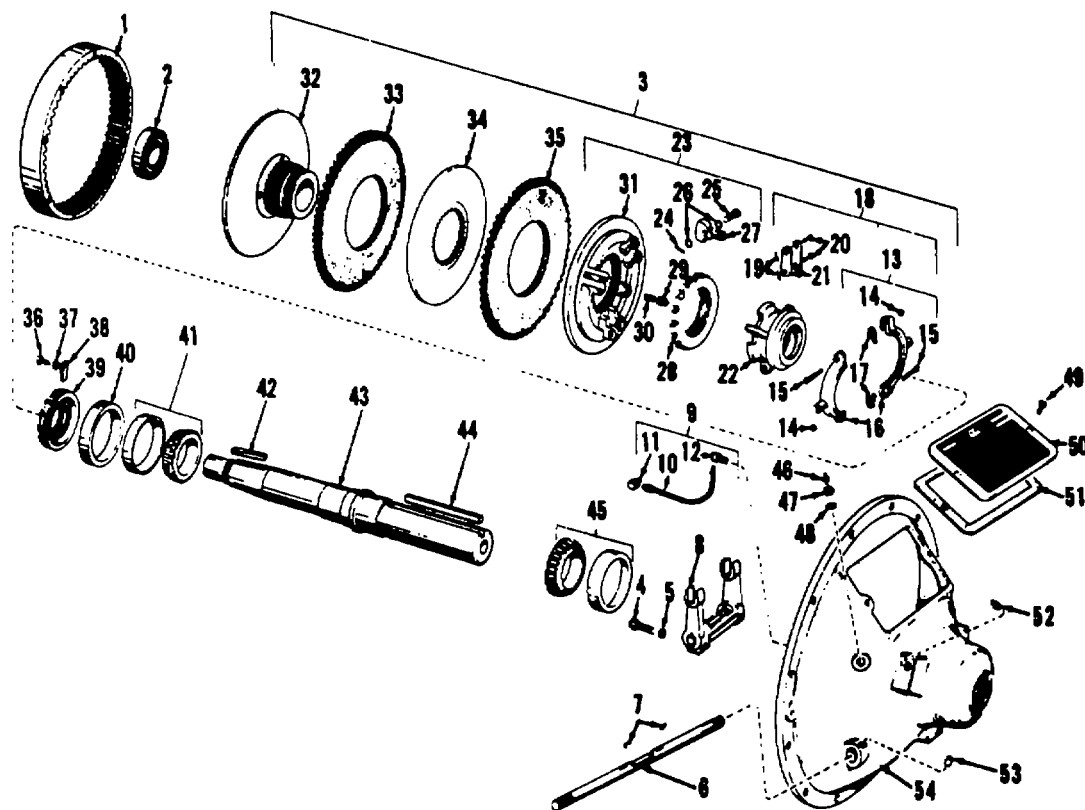

MEC 3810-227-15/190

- |                   |                            |                            |
|-------------------|----------------------------|----------------------------|
| 1 Driving ring    | 10 Flexible hose           | 19 Roll pin                |
| 2 Pilot bearing   | 11 Fitting                 | 20 Link pin                |
| 3 Clutch assembly | 12 Fitting                 | 21 Lever link              |
| 4 Capscrew        | 13 Collar assembly         | 22 Sliding sleeve          |
| 5 Lockwasher      | 14 Hex nut                 | 23 Floating plate assembly |
| 6 Operating shaft | 15 Capscrew                | 24 Roll pin                |
| 7 Keys            | 16 Sleeve collar           | 25 Lever pin               |
| 8 Throwout yoke   | 17 Shim                    | 26 Spring washer           |
| 9 Hose assembly   | 18 Sliding sleeve assembly | 27 Lever                   |

Figure 190. Crane engine clutch and power take-off assembly.

AGO 6819A

28	Adjusting ring	37	Lockwasher	46	Fitting
29	Lock pin	38	Bearing retainer lock	47	Jam nut
30	Lock pin spring	39	Bearing retainer	48	Washer
31	Floating plate	40	Spacer	49	Screw
32	Hub & back plate	41	Bearing assembly	50	Plate
33	Driving plate	42	Hub key	51	Gasket
34	Center plate	43	Shaft	52	Fitting
35	Driving plate	44	Shaft key	53	Fitting
36	Capscrew	45	Bearing assembly	54	Housing

**Figure 190 - Continued**

**341. Crane Engine Cylinder Head Cleaning, Inspection, and Repair**

a. *Cleaning.* Clean all parts with an approved cleaning solvent and dry thoroughly.

b. *Inspection and Repair.* Check flatness of the cylinder head gasket contact surfaces with a straight edge and feeler gauge in three positions lengthwise and five crosswise. The maximum permissible is .004 inches low in the center lengthwise, gradually decreasing towards the ends, or .003 inches crosswise or in localized spots. Replace a defective cylinder head.

**342. Crane Engine Cylinder Head Installation**

a. Install cylinder head and tighten nuts in sequence as instructed in figure 191.

b. Install thermostat and housing assembly (para. 155).

c. Install radiator hose (para. 153).

d. Install distributor (para. 125).

e. Install spark plugs (para. 127).

f. Install generator regulator (para. 134).

g. Fill the cooling system.

**343. Crane Engine Valve Assemblies Removal and Disassembly**

a. *Removal.*

(1) Remove valve covers and gaskets (para. 173).

(2) Remove the cylinder head (para. 340).

(3) Remove the valve assemblies from the engine block as instructed in figure 192.

b. *Disassembly.* Disassemble the valve assemblies in the numerical sequence as illustrated in figure 193.

**344. Crane Engine Valve Assemblies Cleaning, Inspection and Repair**

a. *Cleaning.*

(1) Clean all parts with an approved cleaning solvent.

(2) Clean carbon from valves, valve stems, and cylinder block and from around valve seats and ports.

b. *Inspection and Repair.*

(1) Inspect the valves for burned seats and pitted or bent stems. Stem diameter should be 0.4335 to 0.4345 inch. Replace valves with bent or worn stems or badly burned faces.

(2) Inspect the inside of each valve guide for proper clearance. Intake should be 0.4360 to 0.4370 inch. Exhaust should be 0.4390 to 0.4400 inch. Replace defective or worn valve guides.

(3) Inspect the exhaust valve seat inserts. Replace any that are loose, cracked or otherwise damaged.

(4) Inspect the valve springs for proper tension. They should have a load of 93 to 99 pounds when compressed to 1 3/8 inches. Replace springs when they do not come within limits.

(5) Inspect the tappets for worn threads, scores, cracks, and wear or pitting on the face. Replace defective tappets. Tappet hole diameter should be between 1.125 and 1.126 inch.

(6) Inspect tappet adjusting screws and nut locks for worn or damaged threads. Replace if defective.

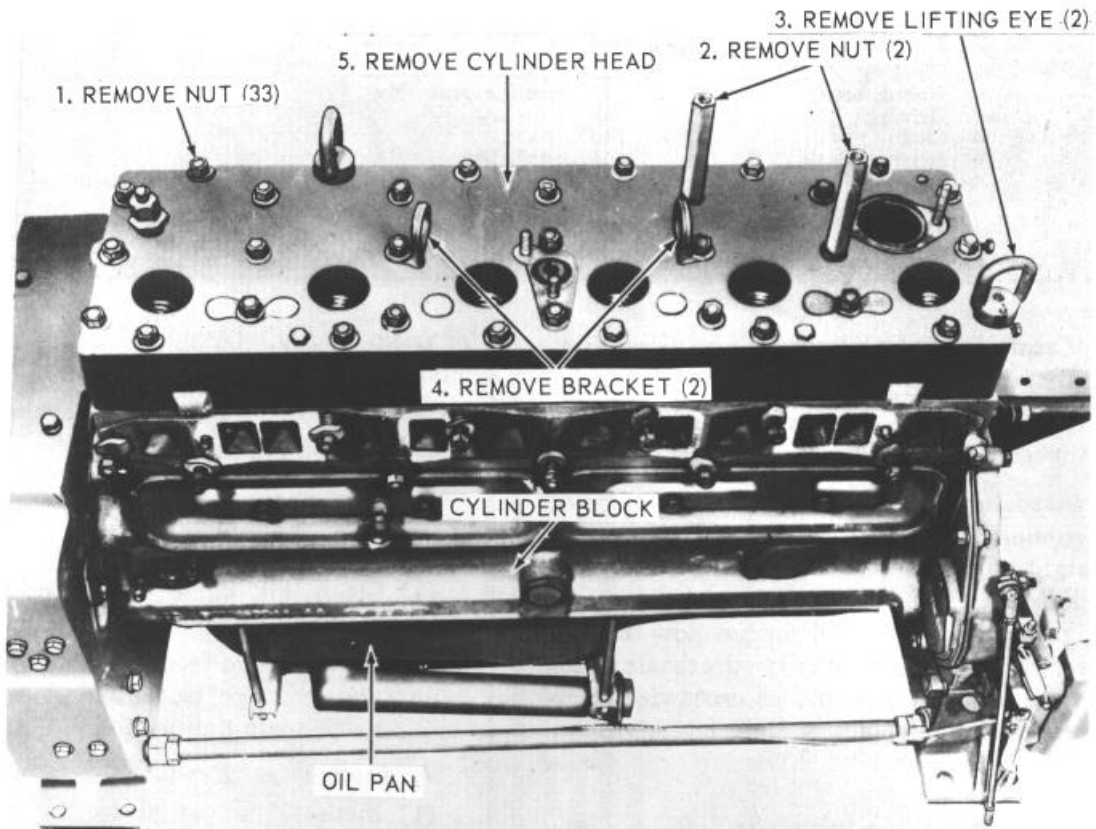

A - Cylinder Head, Installed View.

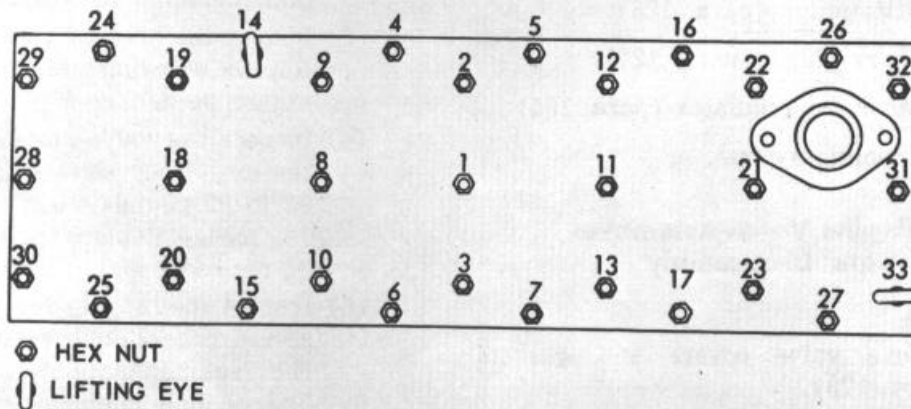

B - Cylinder Head, Nut Tightening Sequence.

MEC 3810-227-15/191

Figure 191. Crane engine cylinder head assembly, removal and installation, and nut tightening sequence.

AGO 6819A

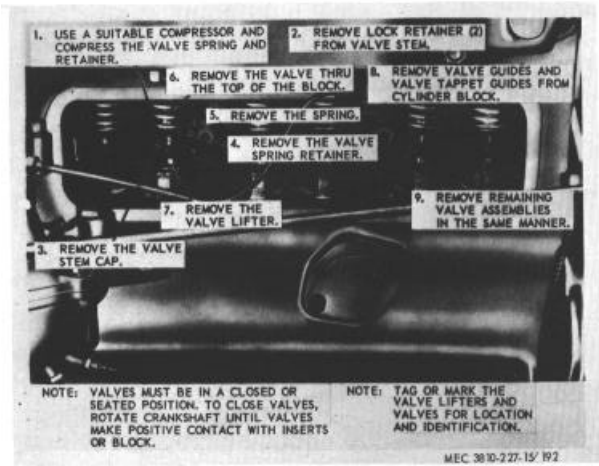

**Figure 192. Crane engine valve assemblies, removal and installation.**

### 345. Crane Engine Valve Assemblies, Reassembly and Installation

a. *Reassembly.* Reassemble the valve assemblies in the reverse of the numerical sequence as illustrated on figure 193.

b. *Installation.*

- (1) Install the valve assemblies in the engine block in the reverse of the instructions on figure 192.
- (2) Install the cylinder head (para. 342).
- (3) Install the valve cover gaskets and valve covers (para. 173).

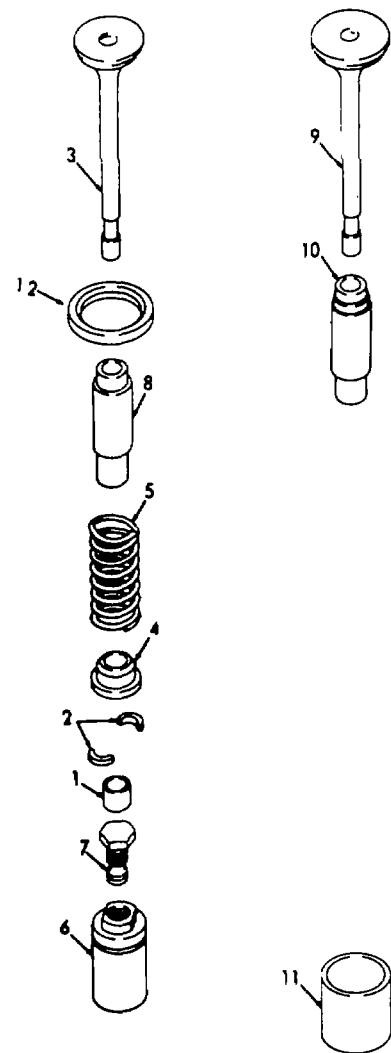

MEC 3810-227-15/193

- 1 Valve stem cap
- 2 Valve spring lock retainer
- 3 Exhaust valve
- 4 Valve spring retainer
- 5 Valve spring
- 6 Tappet
- 7 Adjusting screw
- 8 Exhaust valve guide
- 9 Intake valve
- 10 Intake valve guide
- 11 Valve tappet guide housing
- 12 Valve seat insert

**Figure 193. Crane engine valve assemblies, exploded view.**

## Section XV. CRANE ENGINE OIL PAN AND FILLER BLOCKS

### 346. General

The crane engine oil pan is mounted on the bottom of the engine block and houses the oil for the engine lubricating system.

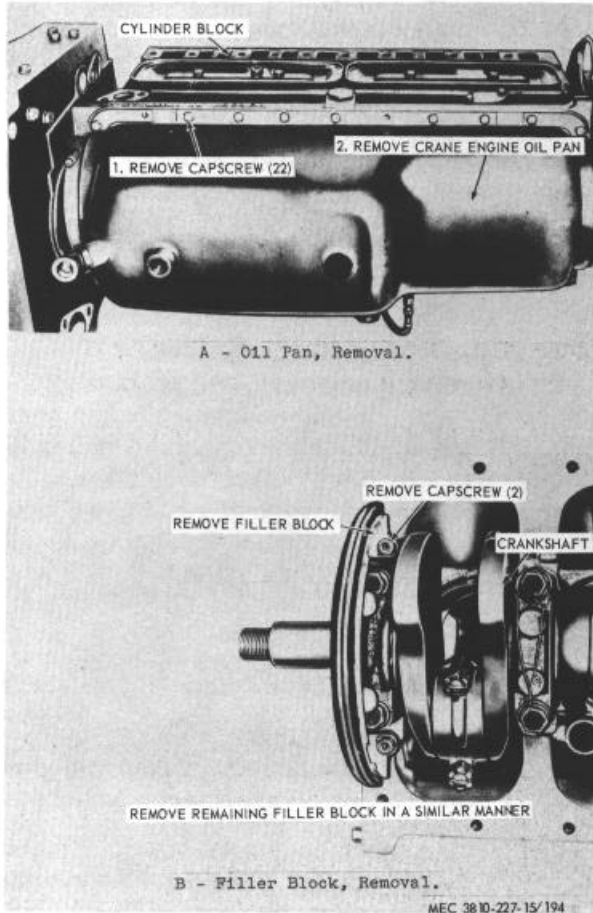

**Figure 194. Crane engine oil pan and filler block, removal and installation**

### 347. Crane Engine Oil Pan and Filler Blocks, Removal and Disassembly

#### a. Removal.

- (1) Remove the crane engine (para. 297).
- (2) Remove the oil pan as instructed on figure 194.

194.

#### b. Disassembly. Disassemble the crane engine

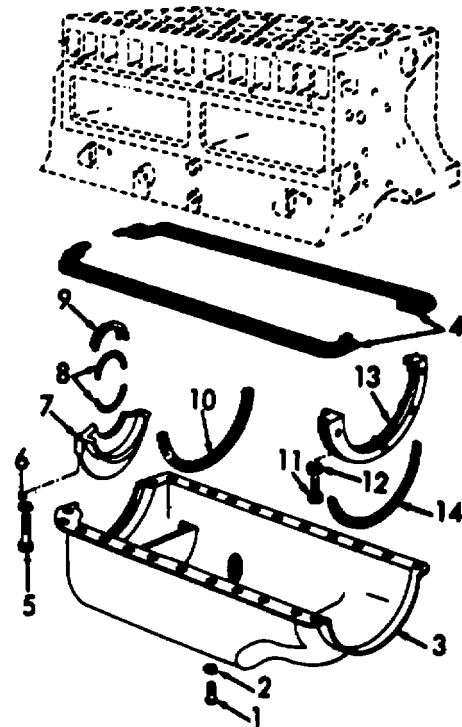

MEC 3810-227-15/195

- |                       |                           |
|-----------------------|---------------------------|
| 1 Screw, cap          | 8 Filler block seal, rear |
| 2 Washer, lock        | 9 Rear bearing oil guard  |
| 3 Oil pan             | 10 Filler block gasket    |
| 4 Oil pan gasket      | 11 Screw, cap             |
| 5 Screw, cap          | 12 Washer, lock           |
| 6 Washer, lock        | 13 Filler block, front    |
| 7 Filler, block, rear | 14 Filler block gasket    |

**Figure 195. Crane engine oil pan and filler block, exploded view.**

oil pan and filler blocks in the numerical sequence as illustrated on figure 195.

### 348. Crane Engine Oil Pan and Filler Block Cleaning and Inspection

a. *Cleaning.* Clean all parts with an approved cleaning solvent and dry thoroughly.

b. *Inspection.* Inspect all parts for excessive wear or damage. Replace all defective parts.

### 349. Crane Engine Oil Pan and Filler Blocks Reassembly and Installation

a. *Reassembly.* Reassemble the oil pan and

AGO 6819A

filler blocks in the reverse of the numerical sequence as illustrated on figure 195.

b. *Installation.*

- (1) Install the oil pan as illustrated on figure 194.
- (2) Install the crane engine (para. 297).

## Section XVI. CRANE ENGINE OIL PUMP ASSEMBLY

### 350. General

The crane engine oil pump assembly is internally mounted on the underside of the crane engine center bearing cap. The pump is the helical-gear type and is driven by a special gear on the camshaft. Equipped with an oil screen which floats near the top of oil in the crankcase, the pump takes the cleanest portion of the oil rather than using the portion at the bottom of the oil pan where any sediment might have collected. The oil pump supplies oil pressure to the main bearings, connecting rod bearings, camshaft bearings, and timing gears. The oil pump forces oil through the oil filter and the oil cooler. When the engine is hot, the pump delivers from 10 to 15 pounds per square inch pressure at sustained governed speed.

### 351. Crane Engine Oil Pump Assembly Removal and Disassembly

a. *Removal.*

- (1) Remove the crane engine oil pan (para. 347).
- (2) Remove the oil pump assembly as instructed on figure 196.

b. *Disassembly.* Disassemble the oil pump assembly in the numerical sequence as illustrated on figure 197.

### 352. Crane Engine Oil Pump Assembly Cleaning, Inspection and Repair

a. *Cleaning.* Clean all parts with an approved cleaning solvent and dry thoroughly.

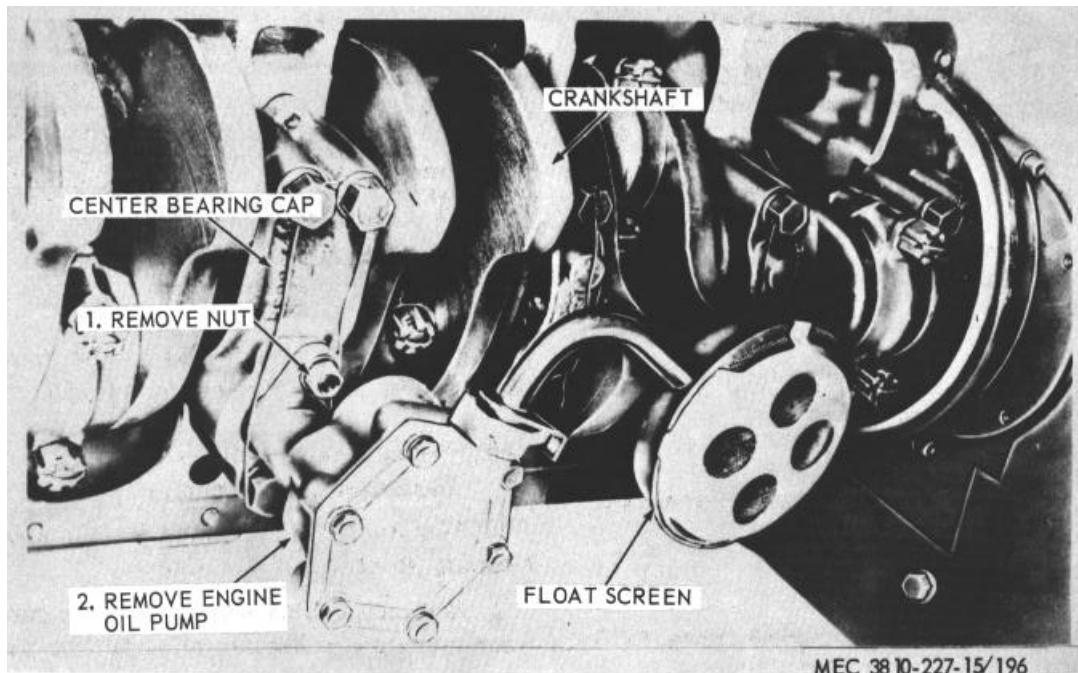

Figure 196. Crane engine oil pump, removal and installation.



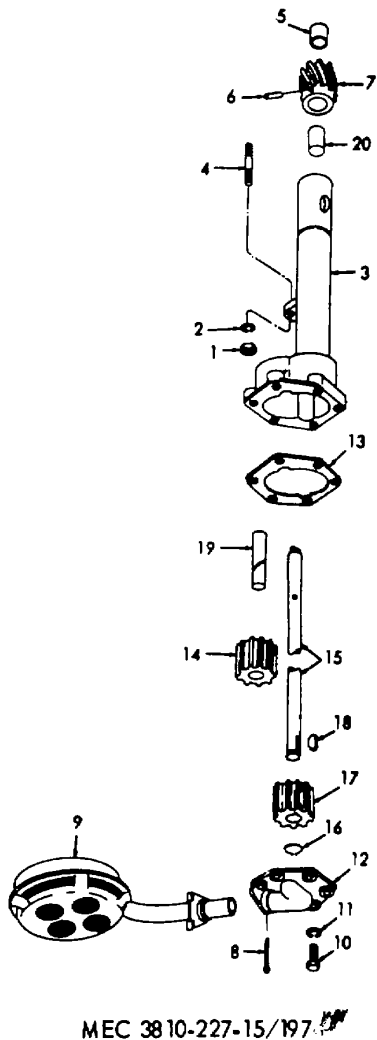

Figure 197. Crane engine oil pump assembly, exploded view.

b. *Inspection and Repair.* Inspect all parts for excessive wear or damage. Replace or repair all defective parts.

### 353. Crane Engine Oil Pump Assembly Reassembly and Installation

a. *Reassembly.* Reassemble the oil pump in the reverse of the numerical sequence as illustrated on figure 197.

b. *Installation.*

- (1) Install the oil pump assembly as illustrated on figure 196.
- (2) Install the crane engine oil pan (para. 349).

1	Nut	11	Washer, lock
2	Washer, lock	12	Cover
3	Body	13	Gasket
4	Stud	14	Idler gear
5	Sleeve	15	Drive shaft
6	Pin	16	Snap ring
7	Helical gear	17	Drive gear
8	Pin, cotter	18	Key
9	Float, screen	19	Shaft
10	Screw, cap	20	Bushing

## Section XVII. CRANE ENGINE PISTON AND CONNECTING ROD ASSEMBLIES

### 354. General

The pistons used on the crane engine are equipped with four rings each; one chrome ring at top of piston, two compression rings, and one oil ring. The connecting rods have the insert-type bearing shells. The bronze piston pin bushing is pressed in the boss of the connecting rod.

### 355. Crane Engine Piston and Connecting Rod Assemblies Removal and Disassembly

a. *Removal.*

- (1) Remove the crane engine oil pan (para. 347).
- (2) Remove the crane engine cylinder head (para. 340).

AGO 6819A

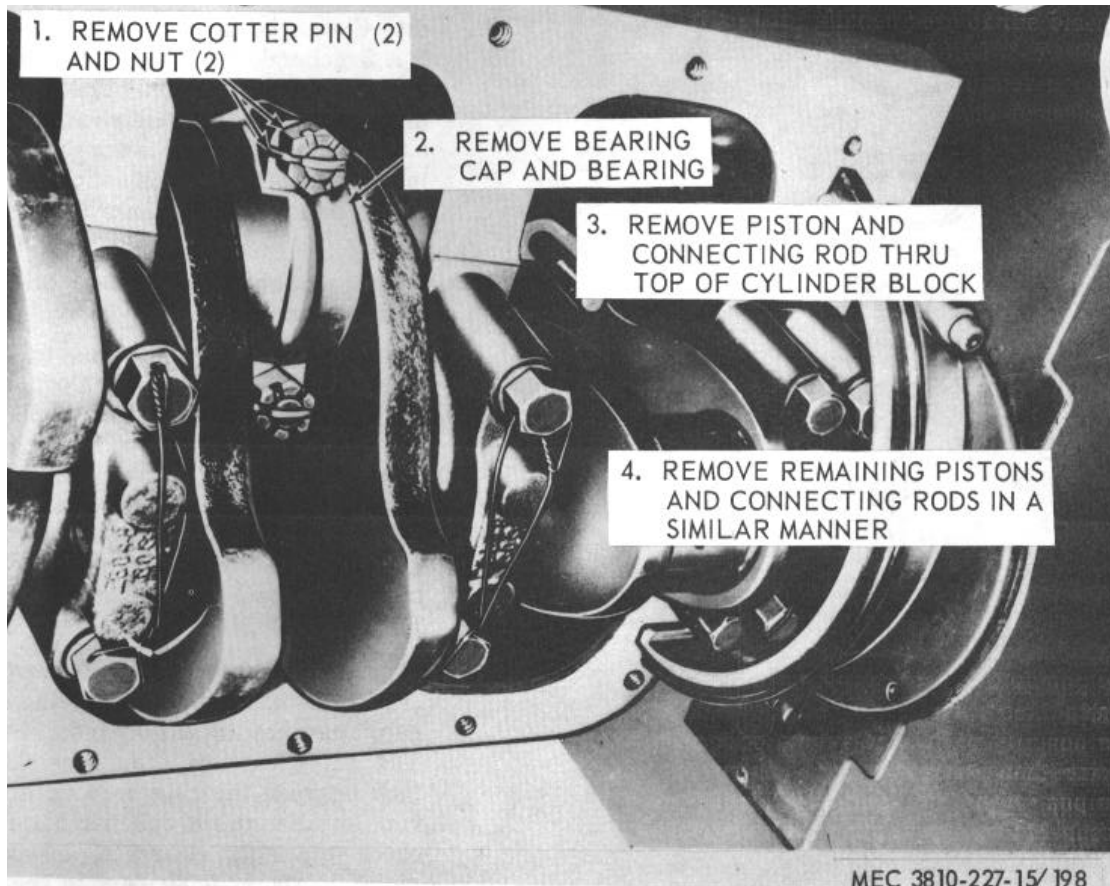

**Figure 198. Crane engine piston and connecting rod assembly, removal and installation.**

- (3) Remove the crane engine piston and connecting rod assemblies from the engine block as instructed on figure 198.

*b. Disassembly.* Disassemble the piston and connecting rod assemblies in the numerical sequence as illustrated on figure 199.

### **356. Crane Engine Piston and Connecting Rod Assemblies Cleaning, Inspection, and Repair**

*a. Cleaning.*

- (1) Clean all parts with an approved cleaning solvent.
- (2) Remove carbon deposits from all parts. Remove all loose carbon particles with compressed air or a lint-free cloth.

*b. Inspection and Repair.*

- (1) Inspect the pistons for wear, galling, scoring, burned condition, and out-of-round. The piston diameter is 4.233 inches minimum and 4.441 inches maximum. The wing groove width diameter is 0.097 inch minimum and 0.098 maximum. Replace defective pistons.
- (2) Inspect piston for cylinder bore fit and clearance. Pistons should be fitted with the cylinder bore of the block at room temperature, 68°-75° F. Check the piston fit in the cylinder bore using a strip of 0.004 inch feeler gauge stock, the feeler being attached to a

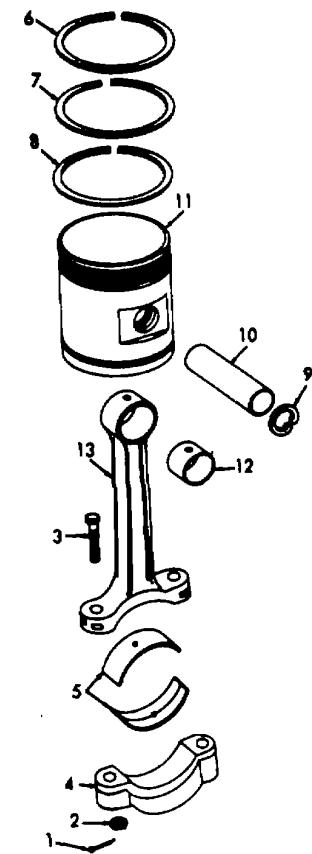

NOTE: THE OTHER FIVE PISTONS AND CONNECTING RODS ARE DISASSEMBLED IN A SIMILAR MANNER.

MEC 38 10-227-15/1 99

1 Pin, cotter	8 Oil ring
2 Nut	9 Retainer
3 Bolt, special	10 Piston pin
4 Rod, cap	11 Piston
5 Bearing shell	12 Bushing
6 Top ring	13 Connecting rod
7 Compression ring	

**Figure 199. Crane engine piston and connecting rod assembly, exploded view.**

small scale of approximately 15 pounds capacity. The correct piston fit is obtained when the feeler gauge can be withdrawn from between the piston and cylinder wall with a pull of 5-10 pounds on the scale. The feeler gauge must be inserted between the piston and cylinder

wall midway between the piston pin bosses, where the diameter of the piston is the greatest. Check the fit of the piston when it is 2 inches down in the cylinder bore in an inverted position. The correct piston to cylinder wall clearance is 0.004 inch. Piston clearance should be in accordance with specification shown in the limits and clearance table.

- (3) Inspect the connecting rods for alignment; straighten or replace all defective connecting rods.
- (4) Inspect piston pin bushings for oil openings and turning in the connecting rod. Replace all defective piston pin bushings. If a new bushing is used, the piston bushing must be reamed to 0.002 inch clearance of the piston pin, and a light push with the hand should install the pin in the bushing at room temperature, 68°-75° F.
- (5) Inspect the piston rings for wear, cracks, breaks, and check the ring end gap clearance in the cylinder bore. The gap clearance should be 0.025 inch between the ring ends with the ring installed in the cylinder bore. To check the ring clearance, insert a piston in the cylinder bore in the inverted position, insert each piston ring one at a time about 2 inches down in the cylinder bore, and bring the bottom edge of the piston up against the ring to square the ring in the cylinder bore. Check the ring end gap with a feeler gauge. If the ring end gap clearance is not as specified, the ring must be filed or honed to specification, or the ring must be replaced.
- (6) Check the clearance between the connecting rod bearings and the throws on the crankshaft. The proper clearance of the connecting rod bearings is 0.0012 inch minimum to 0.0039 inch maximum. The desired connecting rod bearing clearance is 0.0025 inch. If the connecting rod bearing clearance is not specified, replace the connecting rod bearing or replace the crankshaft.

AGO 6819A

**357. Crane Engine Piston and Connecting Rod Assemblies Reassembly and Installation**

a. *Reassembly.* Reassemble the crane engine piston and connecting rod assemblies in the reverse of the sequence as illustrated on figure 199.

b. *Installation.*

- (1) Install the crane engine piston and connecting rod assemblies in the, engine block in the reverse of the instructions on figure 198.
- (2) Install the crane engine cylinder head (para. 342).
- (3) Install the crane engine oil pan (para. 849).

**Section XVIII. CRANE ENGINE FLYWHEEL AND FLYWHEEL HOUSING**

**358. General**

The crane engine flywheel is attached to the crankshaft flange at the rear of the crane engine. A flywheel ring gear that meshes with the starter pinion to turn the engine over is shrunk on the forward surface of the flywheel. The housing also bolts to the clutch housing.

**359. Crane Engine Flywheel and Flywheel Housing Removal and Disassembly**

a. *Removal.*

- (1) Remove the starter (para. 129).
- (2) Remove the crane engine (para. 297).
- (3) Remove the crane engine clutch (para. 886).
- (4) Remove the flywheel and flywheel housing as instructed on figure 200.

b. *Disassembly.* Disassemble the flywheel and ring gear in numerical sequence as illustrated on figure 201.

**360. Crane Engine Flywheel and Flywheel Housing Cleaning, Inspection and Repair**

a. *Cleaning.* Clean all parts with an approved cleaning solvent and dry thoroughly.

b. *Inspection and Repair.* Inspect all parts for excessive wear and damage. Replace or repair all defective parts. With an approved indicator check the flywheel run-out and counterbore. In both cases the maximum indicator reading must not exceed 0.008 inch.

**361. Crane Engine Flywheel and Flywheel Housing Reassembly and Installation**

a. *Reassembly.* Reassemble the flywheel and flywheel housing in the reverse of the numerical sequence as illustrated on figure 201.

b. *Installation.*

- (1) Install the flywheel and flywheel housing as illustrated on figure 200.
- (2) Install the crane engine clutch (para. 388).
- (3) Install the crane engine (para. 297).
- (4) Install the starter (para. 129).

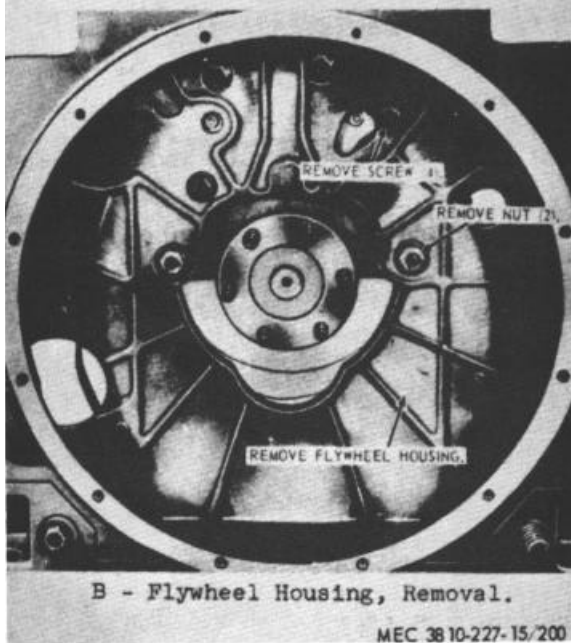
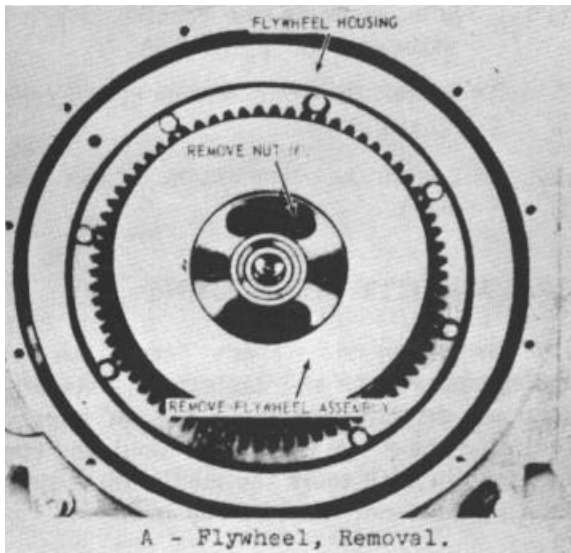
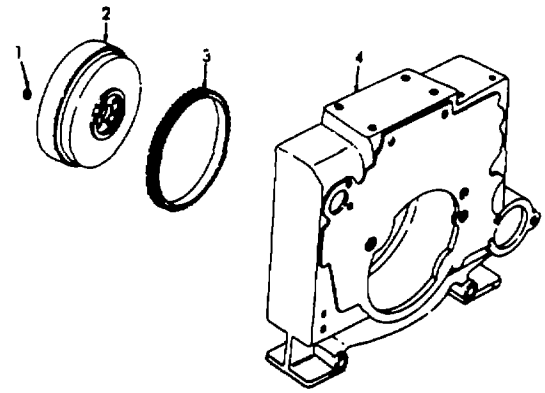

Figure 200. Crane engine flywheel and flywheel housing, removal and installation



MEC 3810-227-15/201

- |            |                    |
|------------|--------------------|
| 1 Nut      | 3 Ring gear        |
| 2 Flywheel | 4 Flywheel housing |

Figure 201. Crane engine flywheel, ring gear, and flywheel housing, exploded view.

**Section XIX. CRANE ENGINE FRONT MOUNT AND PULLEY ASSEMBLY**

**362. General**

The crane engine pulley assembly is connected directly to the engine crankshaft and serves as an

external means for starting the crane engine. The crane engine front mount is bolted to the revolving crane machinery deck.

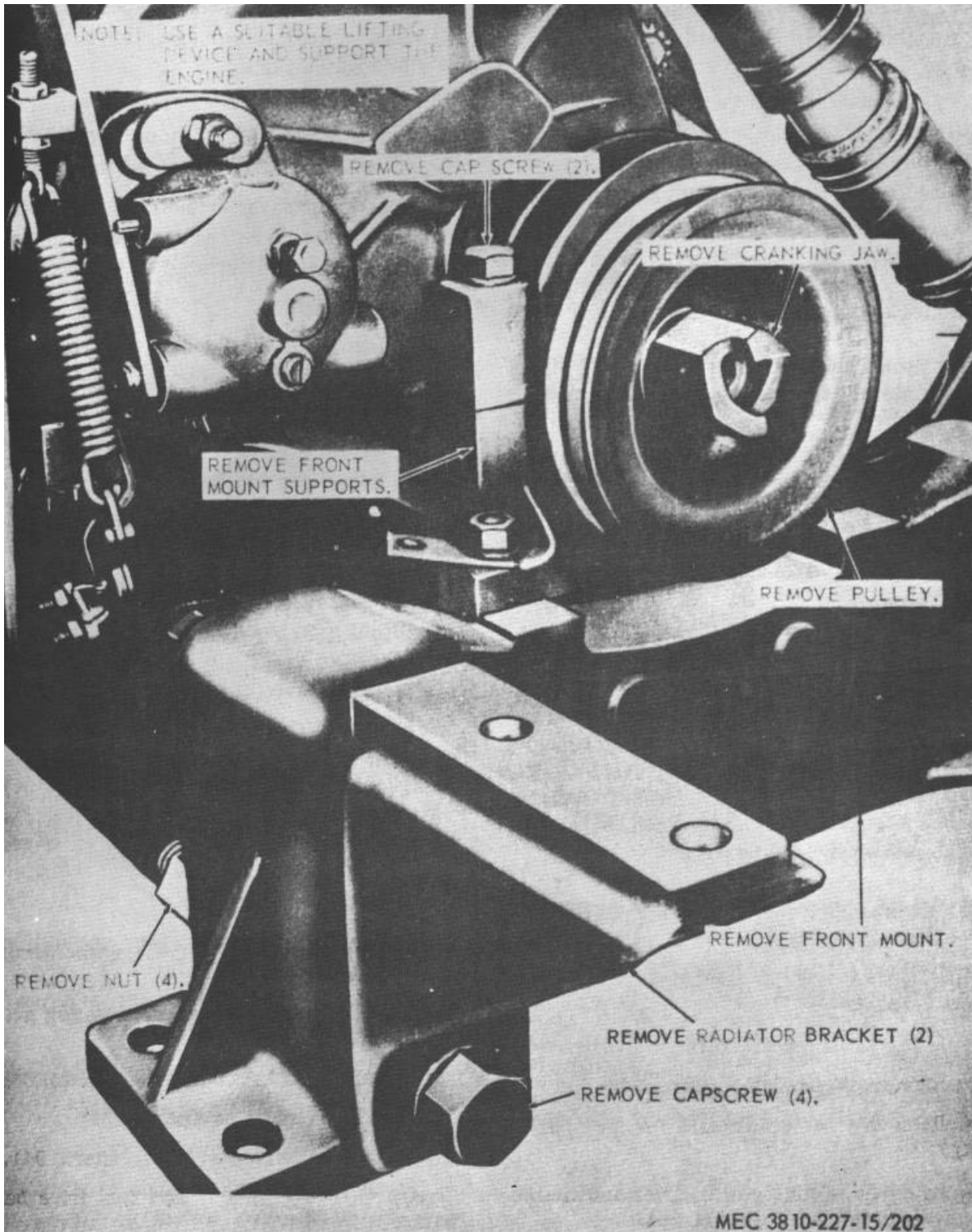

Figure 202. Crane engine front mount and pulley assembly, removal and installation.

**363. Crane Engine Front Mount and Pulley Assembly Removal and Disassembly**

*a. Removal.*

- (1) Remove the fan belts (para. 167).
- (2) Remove the crane engine (para. 297).
- (3) Remove the radiator (para. 328).
- (4) Remove the front mount and pulley assembly as instructed on figure 202.

*b. Disassembly.* Disassemble the front mount and pulley assembly in numerical sequence as illustrated on figure 208.

**364. Crane Engine Front Mount and Pulley Assembly Cleaning, Inspection, and Repair**

*a. Cleaning.* Clean all parts with an approved cleaning solvent and dry thoroughly.

*b. Inspection and Repair.* Inspect all parts for excessive wear or damage. Replace or repair all defective parts.

**365. Crane Engine Front Mount and Pulley Assembly Reassembly and Installation**

*a. Reassembly.* Reassemble the front mount and pulley assembly in the reverse of the numerical sequence as illustrated on figure 208.

*b. Installation.*

- (1) Install the front mount and pulley assembly as illustrated on figure 202.
- (2) Install the radiator (para 880).
- (3) Install the crane engine (para. 297).
- (4) Install the fan belts (para. 157).

**Section XX. CRANE ENGINE TIMING GEAR COVER AND TIMING GEARS**

**366. General**

The crane engine timing gear cover is used for the front engine mount and increases the crankshaft and camshaft gears. It is also used to mount the engine speed governor. The crankshaft and camshaft gears are helically cut to provide greatest meshing surface. The crankshaft gear drives the camshaft gear at one-half engine speed. The camshaft gear drives the engine speed governor.

**367. Crane Engine Timing Gear Cover and Timing Gears Removal**

- a.* Remove the fan and generator drive belts (paras. 131 and 157).
- b.* Remove the engine governor (para. 94).
- c.* Remove the radiator (para. 328).
- d.* Remove the crankshaft pulley (para. 863)
- e.* Remove the timing gear cover and timing gears as instructed on figure 204.

**368. Crane Engine Timing Gear Cover and Timing Gears Cleaning and Inspection**

*a. Cleaning.* Clean all parts with an approved cleaning solvent and dry thoroughly.

*b. Inspection.* Inspect the gears for excessive wear and damage. Check the backlash of the timing gears. Force the mating teeth as far apart as possible with a feeler gauge; if the clearance is 0.002 inch or greater, the gears must be replaced. Always replace gears in pairs.

**369. Crane Engine Timing Gear and Timing Gears Installation**

- a.* Install the timing gears and timing gears cover as illustrated on figure 204.
- b.* Install the crankshaft pulley (para. 865).
- c.* Install the radiator (para. 880).
- d.* Install the engine governor (para. 94).
- e.* Install the generator and fan drive belts (paras. 181 and 157).

AGO 6819A

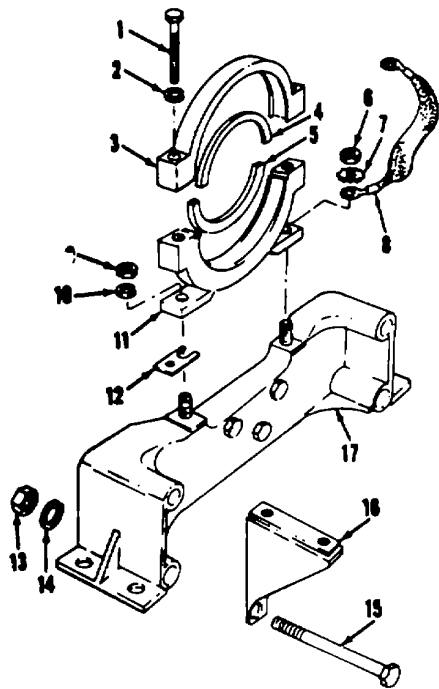

- |                     |                     |
|---------------------|---------------------|
| 1 Screw, cap        | 9 Nut               |
| 2 Washer, lock      | 10 Washer, lock     |
| 3 Trunnion, upper   | 11 Trunnion, lower  |
| 4 Liner             | 12 Shim             |
| 5 Liner             | 13 Nut              |
| 6 Nut               | 14 Washer, lock     |
| 7 Washer, lock, IET | 15 Screw, cap       |
| 8 Ground strap      | 16 Radiator support |

Figure 203. Crane engine front mount assembly, exploded view.

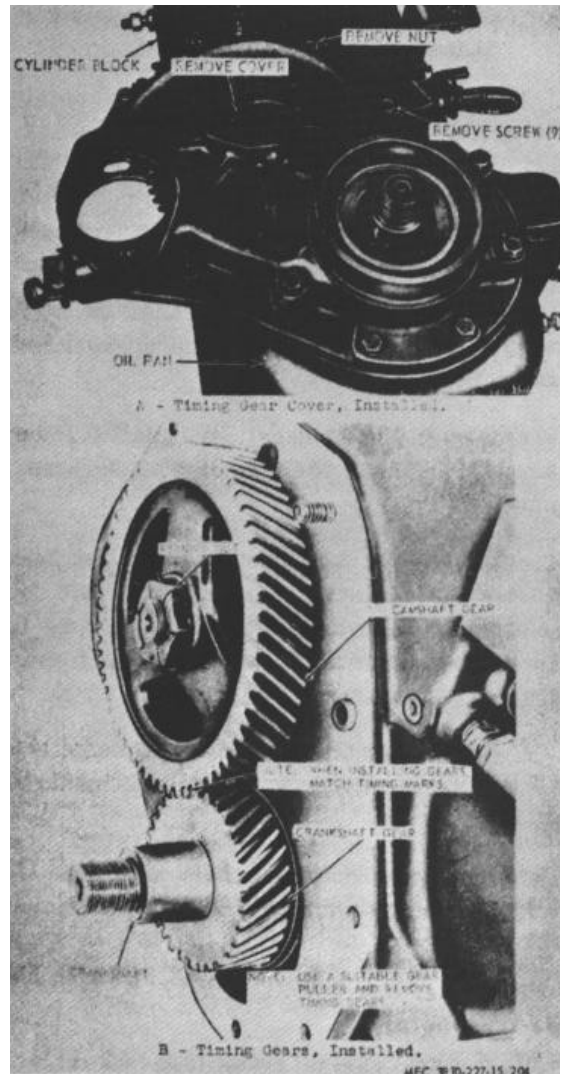

Figure 204. Timing gear cover and timing gears, removal and installation.

## Section XXI. CRANE ENGINE CAMSHAFT ASSEMBLY

### 370. General

The crane engine camshaft assembly is driven by means of the camshaft gear which meshes with the crankshaft gear mounted on the crankshaft. The camshaft is supported in the cylinder block by four removable bearings. The camshaft, in conjunction with the tappets, opens and closes the valves. The camshaft operates the oil pump through a gear on the oil pump and gear on the camshaft.

AGO 6819A

### 371. Crane Engine Camshaft Assembly Removal

- a. Remove the front mount and pulley (para. 363).
- b. Remove the valves (para. 343).
- c. Remove the oil pump (para. 351).
- d. Remove the timing gears (para. 367).
- e. Remove the camshaft assembly as instructed on figure 205.



### 372. Crane Engine Camshaft Assembly Cleaning and Inspection

a. Clean all parts with an approved cleaning solvent and dry thoroughly.

b. Inspect the camshaft bearing journal for diameter of 2.242 inch minimum to 2.243 inch maximum.

c. Inspect the cam lift clearance, the intake should be 0.3395 inch, and the exhaust 0.352 inch.

d. Inspect the camshaft end play for clearance of 0.005 inch minimum to 0.009 inch maximum.

e. Inspect the camshaft bushings for tolerance of 2.2445 inch minimum and 2.2450 inch maximum. Inspect the bushing clearance for 0.0015 inch minimum and 0.0030 inch maximum, with an allowable wear of 0.005 inch.

f. Inspect the tappet hole for a diameter of 1.125 inch minimum to 1.126 inch maximum diameter.

g. Inspect the tappet hole clearance for 0.0006 inch minimum to 0.002 inch maximum.

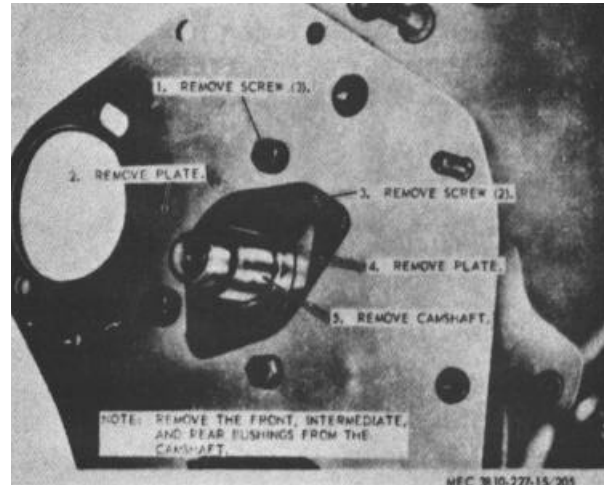

Figure 205. Crane engine camshaft assembly, removal and installation.

### 373. Crane Engine Camshaft Assembly Installation

a. Install the camshaft assembly as illustrated on figure 205.

b. Install the timing gears (para. 369).

c. Install the oil pump (para. 353).

d. Install the valves (para. 345).

e. Install the front mount and pulley (para. 365).

## Section XXII. CRANE ENGINE CRANKSHAFT ASSEMBLY

### 374. General

The crane engine crankshaft assembly is forged of high carbon steel and is carried on seven large main bearings. Special attention must be paid to the end play of the crankshaft as excessive play may cause damage to the front main bearings. The crankshaft is drilled for continuous lubrication. It is both statically and dynamically balanced. The front end of the shaft is machined to extend through the oil seal in the front cover, to accommodate the fan drive pulley.

### 375. Crane Engine Crankshaft Assembly Removal and Disassembly

#### a. Removal.

(1) Remove the front mount and pulley (para. 363).

(2) Remove the flywheel and housing (para. 359).

(3) Remove oil pan and filler blocks (para. 347).

(4) Remove the oil pump (para. 851).

(5) Remove the connecting rod caps (para. 355).

(6) Remove the timing gears (para. 367).

(7) Remove the crankshaft assembly as instructed on figure 206.

b. *Disassembly.* Disassemble the crane engine crankshaft assembly in numerical sequence as illustrated on figure 207.

### 376. Crane Engine Crankshaft Assembly Cleaning, Inspection, and Repair

a. *Cleaning.* Clean all parts in an approved cleaning solvent and dry thoroughly.

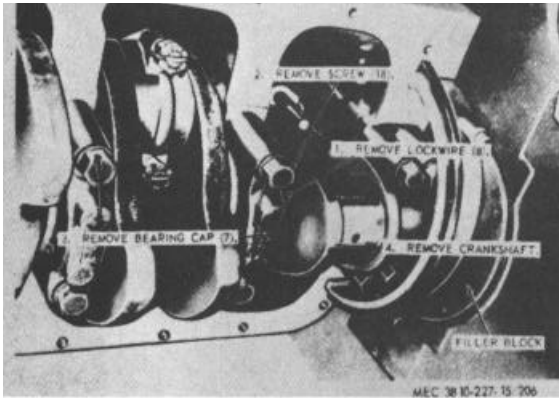

**Figure 206. Crane engine crankshaft assembly, removal and installation.**

*b. Inspection and Repair.*

- (1) Inspect the crankshaft for scored or damaged bearing journals, cracks, breaks, or other damage. Replace a defective crankshaft as necessary.
- (2) Inspect the connecting rod bearings and crankshaft main bearings for scores, cracks, breaks, or excessive wear.
- (3) Inspect the bearing caps for breaks, cracks, or other damage.
- (4) Inspect the main bearing journals, the diameter should measure between 2.9985 and 2.9995 inches.
- (5) Inspect the crankshaft end play, it should measure between 0.005 and 0.008 inch.
- (6) Inspect the crank-pin. The diameter should measure between 2.560 and 2.561 inches. The length should measure between 1.6855 and 1.6875 inches.

**377. Crane Engine Crankshaft Assembly Reassembly and Installation**

*a. Reassembly.* Reassemble the crane engine crankshaft assembly as illustrated on figure 207.

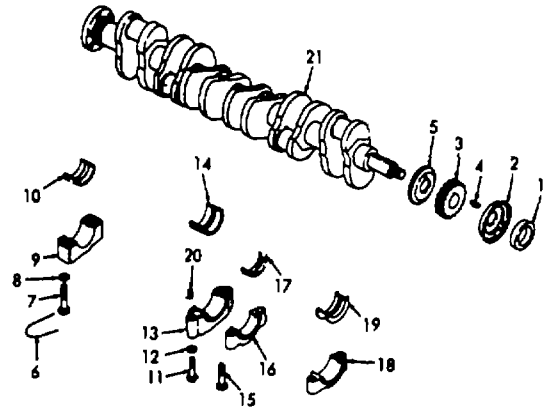

MEC 3810-227-15/207

- 1 Dust seal
- 2 Oil slinger
- 3 Gear
- 4 Key
- 5 Thrust plate
- 6 Lockwire
- 7 Screw, cap, drilled hd.
- 8 Washer, lock
- 9 Crankshaft bearing cap, rear
- 10 Crankshaft bearing, rear
- 11 Screw, cap, drilled hd.
- 12 Washer, lock
- 13 Crankshaft bearing cap, center
- 14 Crankshaft bearing, center
- 15 Screw, cap, drilled hd.
- 16 Crankshaft bearing cap, front and rear intermediate
- 17 Crankshaft bearing, front and rear intermediate
- 18 Crankshaft bearing cap, front
- 19 Crankshaft bearing, front
- 20 Dowel
- 21 Crankshaft

**Figure 207. Crane engine crankshaft assembly, exploded view.**

*b. Installation.*

- (1) Install the crankshaft assembly as illustrated on figure 206.
- (2) Install the timing gears (para. 369).
- (3) Install the connecting rod caps (para. 357).
- (4) Install the oil pump (para. 353).
- (5) Install the oil pan and filler block (para. 349).
- (6) Install the flywheel and housing (para. 361).
- (7) Install the front mount and pulley (para. 365).

## Section XXIII. CRANE ENGINE LOCK

### 378. General

The crane engine block is a solid, one-piece iron-alloy casting. It houses the crankshaft, camshaft, connecting rods, pistons and valves. The block has full length water jacket around the cylinders and has water passages around the valves for cooling. Drilled oil passages carry oil under pressure to all bearings and moving parts requiring lubrication.

### 379. Crane Engine Block Removal and Disassembly

#### a. Removal.

- (1) Remove the carburetor, distributor, governor, generator, fuel pump, generator regulator, water pump and spark plugs (paras. 93, 125, 94, 132, 95, 134, 168, and 127).
- (2) Remove the radiator (para. 328).
- (3) Remove the valves (para. 343).
- (4) Remove the pistons (para. 355).
- (5) Remove the crankshaft (para. 375).
- (6) Remove the camshaft (para. 371).
- (7) Remove the engine block.

b. *Disassembly.* Disassemble the crane block as illustrated on figure 208.

### 380. Crane Engine Block Cleaning and Inspection

a. Soak the engine block in a strong caustic solvent for 2 hours; remove and clean with live steam.

b. Clean water and oil passages.

c. Inspect for wear and damage.

d. Check the machined surfaces of the block with a straight edge and feeler gauge. If the surfaces are warped more than 0.010 inch, replace block as necessary.

e. Inspect all mounting hardware for stripped or damaged threads. Replace all defective hardware as necessary.

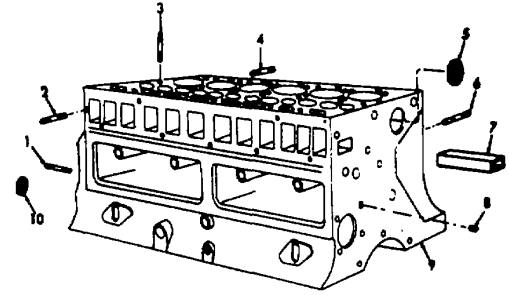

1 Stud	6 Stud
2 Stud	7 Water distribution tube
3 Stud	8 Plug
4 Stud	9 Engine block
5 Freeze plug	10 Freeze plug

Figure 208. Crane engine block, exploded view.

f. Inspect the engine block for breaks, cracks, or other damage. Replace a cracked or broken engine block as necessary.

g. Inspect the cylinder diameter. It should measure between 4.249 and 4.251 inches.

### 381. Crane Engine Block Reassembly and Installation

a. *Reassembly.* Reassemble the crane engine block as illustrated on figure 208.

#### b. Installation.

- (1) Install the engine block.
- (2) Install the camshaft (para. 373).
- (3) Install the crankshaft (para. 377).
- (4) Install the pistons (para. 357).
- (5) Install the valves (para. 345).
- (6) Install the radiator (para. 380).
- (7) Install the carburetor, distributor, governor, generator, fuel pump, generator regulator, water pump, and spark plugs, (paras. 93, 125, 94, 132, 95, 134, 158, and 127).

AGO 6819A

## Section XXIV. CARRIER ENGINE CARBURETOR ASSEMBLY

### 382. General

The carrier carburetor assembly is mounted on the intake manifold on the right side of the carrier engine. The carburetor is a down-draft-type duplex carburetor with a concentric float bowl design. It is a sealed and balanced carburetor as all the air for fuel bowl chamber ventilation and idling must come through the air cleaner.

### 383. Carrier Engine Carburetor Assembly Removal and Disassembly

*a. Removal.* Remove the carrier engine carburetor assembly (para. 86).

*b. Disassembly.* Disassemble the carrier engine carburetor assembly in numerical sequence as illustrated on figure 209.

### 384. Carrier Engine Carburetor Assembly Cleaning, Inspection and Repair

*a. Cleaning.* Clean all parts with an approved cleaning solvent and dry thoroughly.

*b. Inspection and Repair.* Inspect all parts for excessive wear and damage. Replace or repair all defective parts.

### 385. Carrier Engine Carburetor Assembly Reassembly and Installation

*a. Reassembly.* Reassemble the carrier engine carburetor in the reverse of the numerical sequence as illustrated on figure 209.

*b. Installation.* Install the carrier engine carburetor assembly (para. 86).

AGO 6819A

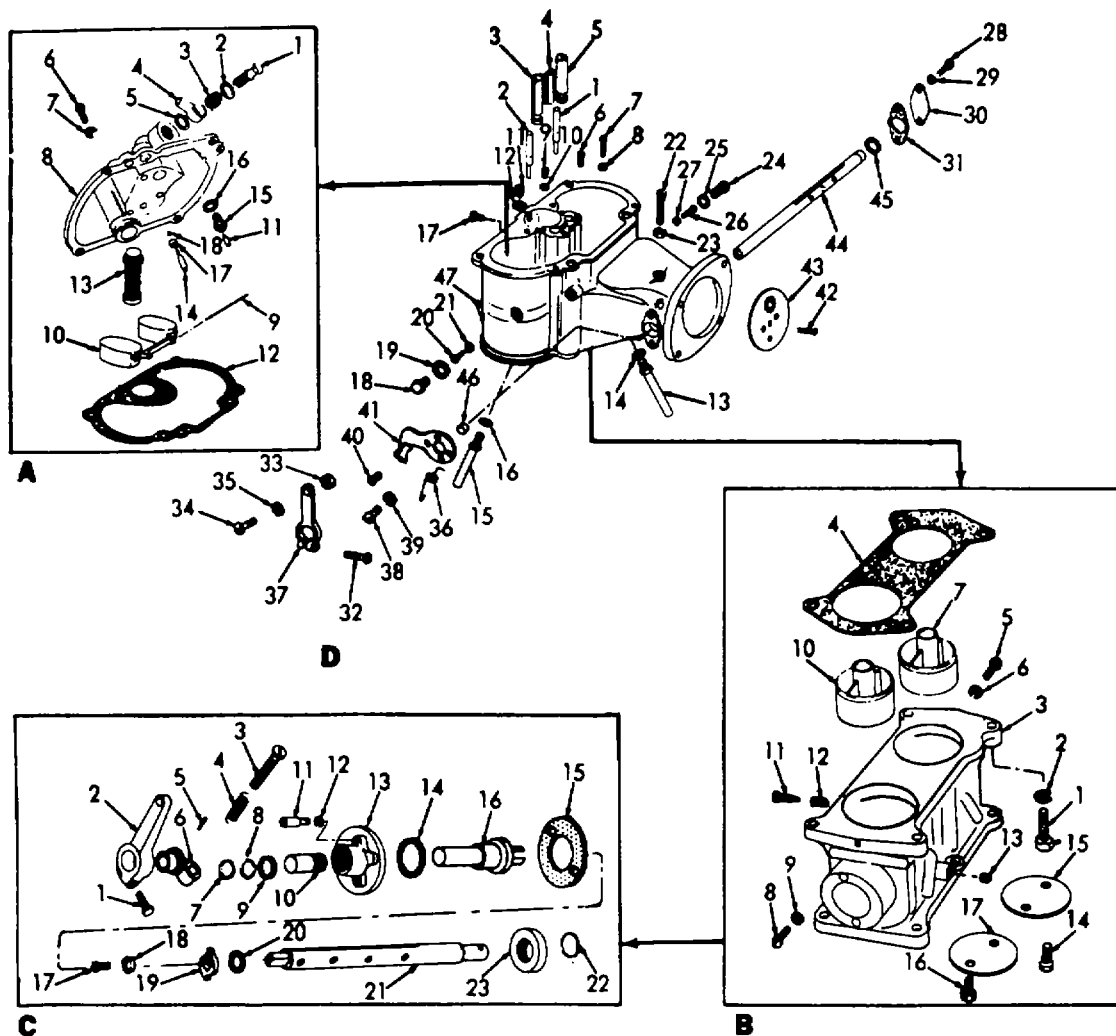

MEC 3810-227-15/209

- 1 Filter plug
- 2 Washer
- 3 Filter screen
- 4 Union body
- 5 Fiber washer
- 6 Screw, cap

- 7 Washer, lock
- 8 Bowl cover
- 9 Float axle
- 10 Float
- 11 Needle valve
- 12 Gasket

- 13 Pump
- 14 Idle jet
- 15 Valve seat
- 16 Seat gasket
- 17 Check valve body
- 18 Check valve ball

A—Carburetor cover, float, pump and idle jets

- 1 Screw
- 2 Washer, lock
- 3 Throttle body
- 4 Gasket
- 5 Screw
- 6 Washer, lock

- 7 Venturi
- 8 Screw
- 9 Washer, lock
- 10 Venturi
- 11 Idle adjusting needle
- 12 Spring

- 13 Plug, pipe
- 14 Screw
- 15 Throttle plate
- 16 Screw
- 17 Throttle plate

B—Carburetor venturi, idle needle, and throttle body

Figure 109. Carrier engine carburetor assembly, exploded view.

1	Screw	7	Bevel washer	13	Support	19	Drive
2	Throttle lever	8	Washer, special	14	Spacer	20	Spacer
3	Screw	9	Packing	15	Gasket	21	Throttle shaft
4	Spring	10	Sleeve-bearing	16	Shaft	22	Snap ring.
5	Pin	11	Idle stop screw	17	Screw	28	Bearing
6	Throttle stop	12	Washer, lock	18	Lock		

**C¾ Carburetor lever and shaft.**

1	Accelerator jet	17	Plug, pipe	33	Nut
2	Accelerator jet	18	Main passage plug	34	Screw
3	Metering well	19	Plug washer	35	Washer, flat
4	Secondary metering well	20	Main jet	36	Choke spring
5	Metering well	21	Jet washer	37	Choke lever
6	Well vent jet	22	Screw	38	Screw
7	Idle Compensator jet	23	Nut	89	Washer, lock
8	Jet washer	24	Main passage plug	40	Screw
9	Pump check valve	26	Plug washer	41	Cover plate
10	Check valve disc	26	Main jet	42	Screw
11	Power jet and valve	27	Jet washer	43	Choke plate
12	Jet valve washer	28	Screw	44	Choke shaft
13	Discharge jet	29	Washer, lock	45	Washer, lock
14	Jet washer	30	Choke shaft cover plate	46	Choke shaft washer
15	Discharge jet	31	Cover plate gasket	47	Fuel bowl
16	Jet washer	32	Screw		

**D¾ Carburetor metering wells, main jets, choke shaft and fuel bowl.**

**Figure 209. Continued.**

**Section XXV. CARRIER ENGINE SPEED GOVERNOR ASSEMBLY**

**386. General**

The carrier engine speed governor is driven by a flexible cable from the auxiliary drive shaft and contains four balanced weights. As the carrier engine runs faster, the spider shaft and weights are revolved faster with the resulting centrifugal force adding upward thrust against the sleeve and collar. The collar actuates the throttle shaft through a bellcrank, spring, and bushing arrangement.

**387. Carrier Engine Speed Governor Assembly Removal and Disassembly**

*a. Removal.* Remove the carrier engine speed governor assembly (para. 87).

*b. Disassembly.* Disassemble the carrier engine speed governor assembly in the numerical sequence as illustrated on figure 210.

**388. Carrier Engine Speed Governor Assembly Cleaning, Inspection and Repair**

*a. Cleaning.* Clean all parts with an approved cleaning solvent and dry thoroughly.

*b. Inspection and Repair.* Inspect all parts for excessive wear and damage. Replace or repair all defective parts.

**389. Carrier Engine Speed Governor Assembly Reassembly and Installation**

*a. Reassembly.* Reassemble the carrier engine speed governor assembly in the reverse of the numerical sequence as illustrated on figure 210.

*b. Installation.* Install the carrier engine speed governor assembly (para. 87).

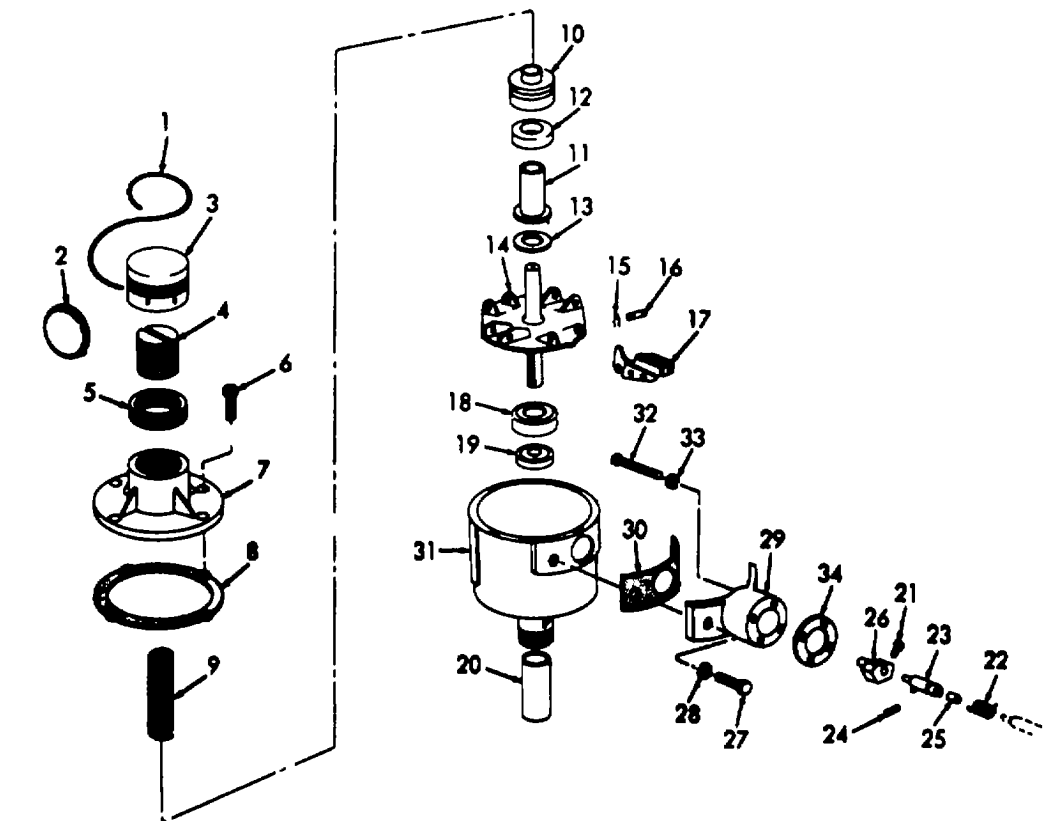

MEC 38 10-227-15/2 10

- |                   |                             |                   |
|-------------------|-----------------------------|-------------------|
| 1 Wire            | 18 Washer                   | 25 Needle bearing |
| 2 Brass seal      | 14 Spider                   | 26 Bellcrank      |
| 3 Cap             | 15 Clip                     | 27 Screw, cap     |
| 4 Adjusting screw | 16 Weight pin               | 28 Washer, lock   |
| 5 Locknut         | 17 Weight                   | 29 Bracket        |
| 6 Screw           | 18 Bearing                  | 30 Gasket         |
| 7 Cap body        | 19 Seal                     | 31 Governor body  |
| 8 Gasket          | 20 Bushing                  | 32 Screw          |
| 9 Spring          | 21 Setscrew                 | 33 Washer         |
| 10 Yoke collar    | 22 Spring                   | 34 Gasket         |
| 11 Thrust sleeve  | 28 Bushing and pin assembly |                   |
| 12 Bearing        | 24 Pin, roll                |                   |

Figure 210. Carrier engine speed governor assembly, exploded view.

## Section XXVI. CARRIER ENGINE GENERATOR ASSEMBLY

### 390. General

The carrier engine generator assembly is a 4-pole, shunt-type-unit with sealed ball bearings in both the drive end frame and the commutator end frame. The generator supplies electrical energy for lights, ignition, and accessories, and it serves to recharge the batteries by furnishing current to make up for cranking and other power supplied by the batteries while the generator is

not in operation. The armature rotates between field coils and produces voltage. The generator is cooled by a fan mounted on the drive pulley. The generated current is discharged to the electrical system through the armature and field terminals. The generator rotates clockwise with a brush tension of 28 ounces. The field current at 80° Fahrenheit is 1.00-1.05 amperes at 24 volts. The cold output of the generator at 4000 revolutions per minute is 40 amperes at 28 volts.

AGO 6819A

**391. Carrier Engine Generator Assembly Removal and Disassembly**

a. *Removal.* Remove the carrier engine generator assembly (para. 105).

b. *Disassembly.* Disassemble the carrier engine generator assembly in a similar manner as described in paragraph 312.

**392. Carrier Engine Generator Assembly Cleaning, Inspection and Repair**

a. *Cleaning.* Clean all parts with an approved cleaning solvent and dry thoroughly.

b. *Inspection and Repair.* Inspect all parts for excessive wear or damage. Replace or repair all defective parts. Refer to TM 5-764 for armature and field coil tests.

**393. Carrier Engine Generator Assembly Reassembly and Installation**

a. *Reassembly.* Reassemble the carrier engine generator assembly in a similar manner as described in paragraph 314.

b. *Installation.* Install the carrier engine generator assembly (para. 105).

**Section XXVII. CARRIER ENGINE STARTER ASSEMBLY**

**394. General**

The carrier engine starter assembly is a heavy-duty type with an over running clutch drive. The starting motor turns at 6,000 rpm, drawing 23.4 volts at 30 maximum amperes with no load, and develops 20 foot-pounds of torque, drawing 6.6 volts at 200 maximum amperes when locked. The starting motor has 4 poles using 8 brushes and has an intermediate bearing to support the armature shaft in the middle, while the ends are supported by bushings.

**395. Carrier Engine Starter Assembly Removal and Disassembly**

a. *Removal.* Remove the carrier engine starter assembly (para. 102).

b. *Disassembly.* Disassemble the carrier engine starter assembly in a similar manner as described in paragraph 320.

**396. Carrier Engine Starter Assembly Cleaning, Inspection and Repair**

a. *Cleaning.* Clean all parts with an approved cleaning solvent and dry thoroughly.

b. *Inspection and Repair.* Inspect all parts for excessive wear or damage. Replace or repair all defective parts. Refer to TM 5-764 for armature and field coil tests.

**397. Carrier Engine Starter Assembly Reassembly and Installation**

a. *Reassembly.* Reassemble the carrier engine starter assembly in a similar manner as described in paragraph 322.

b. *Installation.* Install the carrier engine starter assembly (para. 102).

**Section XXVIII. CARRIER ENGINE DISTRIBUTOR ASSEMBLY**

**398. General**

A waterproof-type distributor is used on the carrier engine. This model is automatic, 24 volts, ground-type with a flange mounting. A waterproof primary connection on the distributor housing encloses a feed through capacitor which is part of the radio interference

suppression circuit built into the distributor. The radio interference suppression system includes another capacitor connected between the ignition coil positive terminal and ground, as well as built-in resistors at each high tension outlet of the molded cap and also one built into the rotor. This type distributor also has built-in shaft



lubrication. The shaft bearing is made of porous metal and extends from the upper to the lower part of the housing, spanning an oil reservoir. During operation, the oil seeps through the bearing, providing continuous shaft lubrication over relatively long periods of time.

#### 399. Carrier Engine Distributor Assembly Removal and Disassembly

a. *Removal.* Remove the carrier engine distributor assembly (para. 98).

b. *Disassembly.* Disassemble the carrier engine distributor assembly in a similar manner as described in paragraph 324.

#### 400. Carrier Engine Distributor Assembly Cleaning, Inspection, and Repair

a. *Cleaning.* Clean all parts with a dry, lint-free cloth and compressed air.

b. *Inspection and Repair.* Inspect all parts for excessive wear or damage. Replace or repair all defective parts.

#### 401. Carrier Engine Distributor Assembly Reassembly and Installation

a. *Reassembly* Reassemble the carrier engine distributor assembly in a similar manner as described in paragraph 326.

b. *Installation.* Install the carrier engine distributor assembly (para. 98).

### Section XXIX. CARRIER ENGINE ACCESSORY DRIVE ASSEMBLY

#### 402. General

The carrier engine accessory drive assembly is externally mounted on the left side of the carrier engine block. The accessory drive assembly is driven from the carrier engine camshaft gear by a helical gear which also drives the carrier engine oil pump assembly. The distributor is mounted on top end of the accessory drive shaft. The drive shaft for the governor drive cable is also mounted on the accessory drive housing and is gear-driven from the accessory drive shaft.

#### 403. Carrier Engine Accessory Drive Assembly Removal and Disassembly

a. *Removal.*

(1) Remove the carrier engine governor drive cable and distributor assembly (para. 98).

(2) Remove the carrier engine accessory drive assembly as instructed on figure 211.

b. *Disassembly.* Disassemble the carrier engine accessory drive assembly in numerical sequence as illustrated on figure 212.

#### 404. Carrier Engine Accessory Drive Assembly Cleaning, Inspection and Repair

a. *Cleaning.* Clean all parts with an approved cleaning solvent and dry thoroughly.

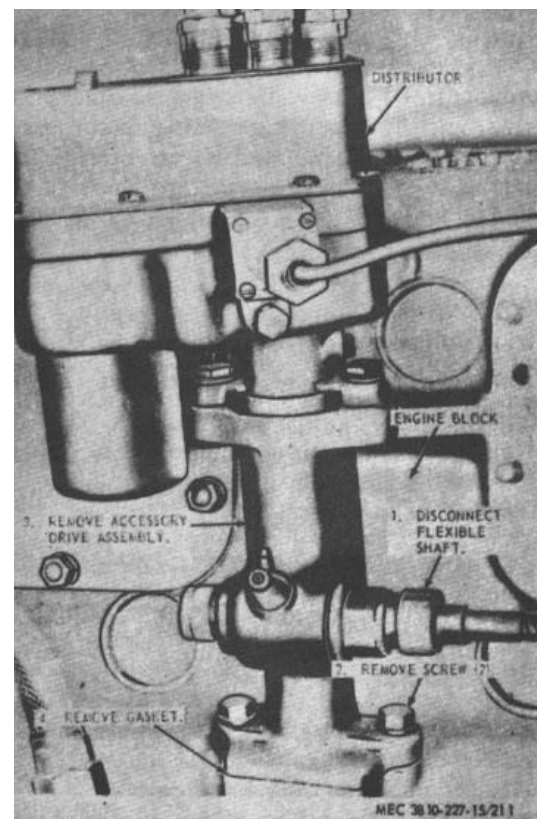
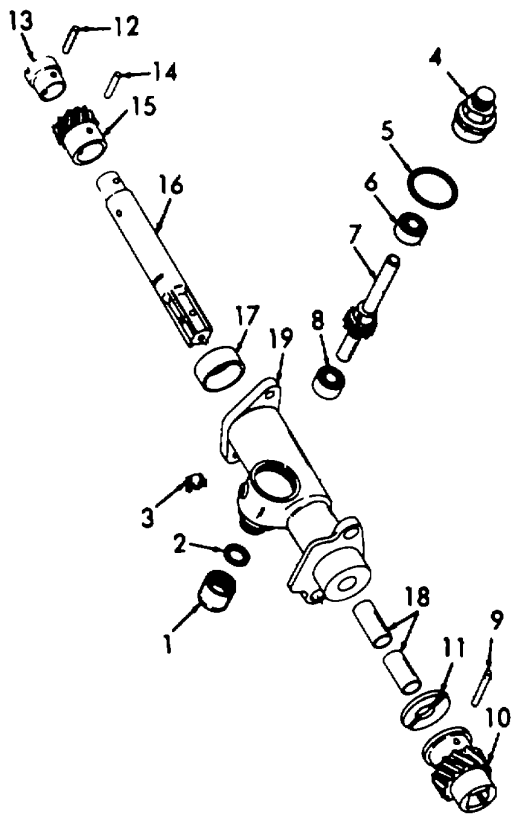

Figure 211. Carrier engine accessory drive assembly removal and installation.



MEC 3810-227-15/212

- |                        |                        |
|------------------------|------------------------|
| 1 Cap                  | 11 Washer, thrust      |
| 2 Gasket               | 12 Pin                 |
| 3 Fitting, lubrication | 13 Coupling            |
| 4 Bearing retainer     | 14 Pin                 |
| 5 Gasket               | 15 Governor drive gear |
| 6 Ball bearing         | 16 Shaft               |
| 7 Gear and shaft       | 17 Sleeve bearing      |
| 8 Ball bearing         | 18 Bushing             |
| 9 Pin                  | 19 Housing             |
| 10 Gear                |                        |

Figure 21. Carrier engine accessory drive assembly, exploded view.

### Section XXX. CARRIER ENGINE RADIATOR ASSEMBLY

#### 406. General

The carrier engine radiator assembly consists of an upper tank, core, and a lower tank. The upper and lower tanks are soldered to the core. The radiator filler is welded into the upper tank and the overflow tube is soldered in the filler. The radiator has an inlet opening

*b. Inspection and Repair.* Inspect all parts for excessive wear and damage. Replace or repair all defective parts.

#### 405. Carrier Engine Accessory Drive Assembly Reassembly and Installation

*a. Reassembly.* Reassemble the carrier engine accessory drive assembly in the reverse of the numerical sequence as illustrated on figure 212.

*b. Installation.*

- (1) Install the carrier engine accessory drive assembly as illustrated on figure 211.
- (2) Install the distributor assembly and carrier engine governor drive cable (para, 98).

welded into the lower tank and a drain valve threaded in the lower portion of the lower tank.

#### 407. Carrier Engine Radiator Assembly Removal

- a.* Drain the carrier engine radiator.
- b.* Disconnect the radiator hoses (para. 148).

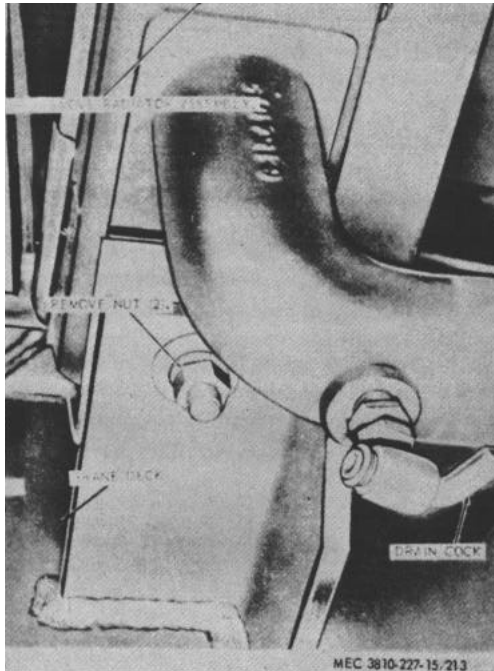

**Figure 213. Carrier engine radiator assembly, removal and installation.**

- c. Remove the fan and fan shroud (paras. 146 and 147).
- d. Remove the carrier engine radiator assembly as instructed on figure 213.

**408. Carrier Engine Radiator Assembly Cleaning, Inspection and Repair**

- a. Flush the inside of the radiator with an approved cleaning solvent.
- b. Clean the radiator core with compressed air or water under pressure from the fan side of the core.
- c. Clean the overflow lines with compressed air.
- d. Plug all openings in the radiator.
- e. Insert air hose in radiator outlet pipe and caulk around hose.
- f. Immerse the radiator in water and apply 5 psi air pressure to the radiator.
- g. Watch for signs of air bubbles.
- h. Remove the radiator from the water and disconnect the air hose.
- i. Replace or repair a damaged or defective radiator.

**409. Carrier Engine Radiator Assembly Installation**

- a. Install the carrier engine radiator assembly as illustrated on figure 213.
- b. Install the fan and shroud (paras. 146 and 147).
- c. Connect the radiator hoses (para. 148).
- d. Fill the radiator.

**Section XXXI. CARRIER ENGINE WATER PUMP ASSEMBLY**

**410. General**

The carrier engine water pump assembly is a centrifugal-type pump, packless, having a spring-loaded, carbon-graphite seal riding against a polished steel face. The shaft is carried on two ball bearings, and driven with V-belts from the crankshaft.

**411. Carrier Engine Water Pump Assembly Removal and Disassembly**

- a. *Removal.* Remove the carrier engine water pump assembly (para. 149).

- b. *Disassembly.* Disassemble the carrier engine water pump assembly in numerical sequence as illustrated on figure 214.

**412. Carrier Engine Water Pump Assembly Cleaning, Inspection and Repair**

- a. *Cleaning.* Clean all parts with an approved cleaning solvent and dry thoroughly.
- b. *Inspection and Repair.* Inspect all parts for excessive wear and damage. Replace or repair all defective parts.

#### 413. Carrier Engine Water Pump Assembly Reassembly and Installation

a. *Reassembly.* Reassemble the carrier engine

water pump assembly in the reverse of the numerical sequence as illustrated on figure 214.

b. *Installation.* Install the carrier engine water pump assembly (para. 149).

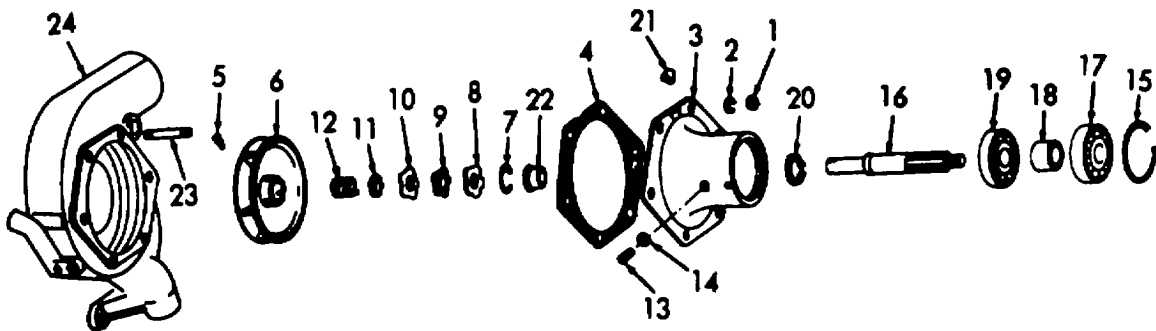

MEC 3810-227-15/214

1 Nut	7 Snap ring	13 Screw, brass	19 Bearing
2 Washer, lock	8 Carbon seal	14 Nut	20 Retaining ring
3 Support	9 Rubber seal	15 Retaining ring	21 Fitting, lubrication
4 Gasket	10 Seal retainer	16 Shaft	22 Sleeve bearing
5 Pin	11 Retaining ring	17 Bearing	23 Stud
6 Impeller	12 Spring	18 Spacer	24 Body

Figure 214. Car engine water pump assembly, exploded view.

### Section XXXII. CARRIER ENGINE OIL FILTER BASE AND OIL COOLER ASSEMBLY

#### 414. General

The carrier engine oil filter base and oil cooler assembly are mounted on the left side of the engine block. The filter base also serves as the housing for the cooler. Oil forced from the oil pump is circulated to the oil cooler by means of a cross passage and gallery line in the engine block. To prevent the oil passages from becoming plugged by the sludge and lacquer, and shutting off the oil from the engine, a bypass valve opens when sufficient resistance builds up in the oil cooler allowing the oil to go directly from the pump into the main oil gallery line. Water from the engine cooling system circulates through the cooler to provide the exchange of heat necessary for safe operating temperature.

#### 415. Carrier Engine Oil Filter Base and Oil Cooler Assembly Removal

a. Remove the carrier engine assembly (para. 298).

b. Remove the oil filters from the oil filter base and oil cooler assembly, (fig. 18).

c. Remove the oil filter base and oil cooler assembly from the engine block as instructed on figure 215.

#### 416. Carrier Engine Oil Filter Base and Oil Cooler Assembly Cleaning, Inspection, Testing and Repair

a. *Cleaning.*

- (1) Clean all parts with an approved cleaning solvent. Dry thoroughly.
- (2) Remove all gasket residue from engine block.
- (3) Soak the cooler in an approved solvent to loosen the corrosion and sludge deposits. Fill and drain the water passage of the cooler with solvent several times to assure the removal of any foreign matter from inside the cooler.

Blow out all passages of the cooler with clean compressed air. Dry thoroughly.

*b. Inspection, Testing, and Repair.*

- (1) Inspect the oil filter base for cracks, breaks, chips, or other damage and for pits, burrs, or warping along mating surfaces. Replace a defective oil filter base assembly.
- (2) Inspect the oil cooler for cracks, breaks, dents, or other damage.
- (3) Test the oil cooler as follows:
  - (a) Plug one of the water passages.
  - (b) Insert an air hose in the oil passage.
  - (c) Immerse the cooler in water and apply 15 to 20 pounds of air pressure.
  - (d) Watch for bubbles. When they appear, note the position of the leaks. Mark the cooler for repair. Solder the leaks with care, making sure solder does not leak into core passages where it would obstruct the flow of water.
- (4) Replace all gaskets each time the oil filter base assembly and oil cooler are removed.

**417. Carrier Engine Oil Filter Base and Oil Cooler Assembly Installation**

a. Install the carrier engine oil filter base and oil cooler assembly on the engine block as instructed on figure 216.

b. Install the oil filters on the carrier engine oil filter base and oil cooler assembly (fig. 18).

c. Install the carrier engine assembly (para. 298).

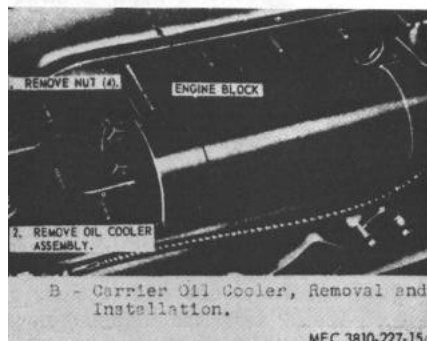
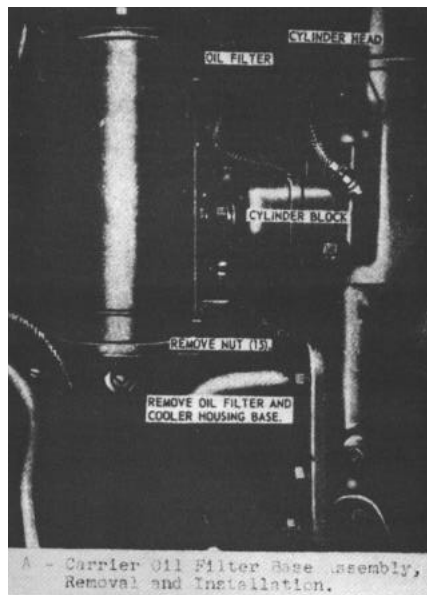

**Figure 215. Carrier engine oil filter base and oil cooler assembly, removal and installation.**

**Section XXXIII. CARRIER ENGINE ROCKER ARM AND PUSH RODS ASSEMBLY**

**418. General**

An overhead valve system is used on the carrier engine. Cam actuated push rods operate the rocker arms mounted on the engine cylinder head and enclosed within oil-tight covers. The action of the rocker

arms opens and closes the valves during each engine cycle. Drilled passages in the cylinder head provide lubrication for the rocker arm assemblies, and ports on the side of the engine provide passages for fuel vapors and exhaust gases.

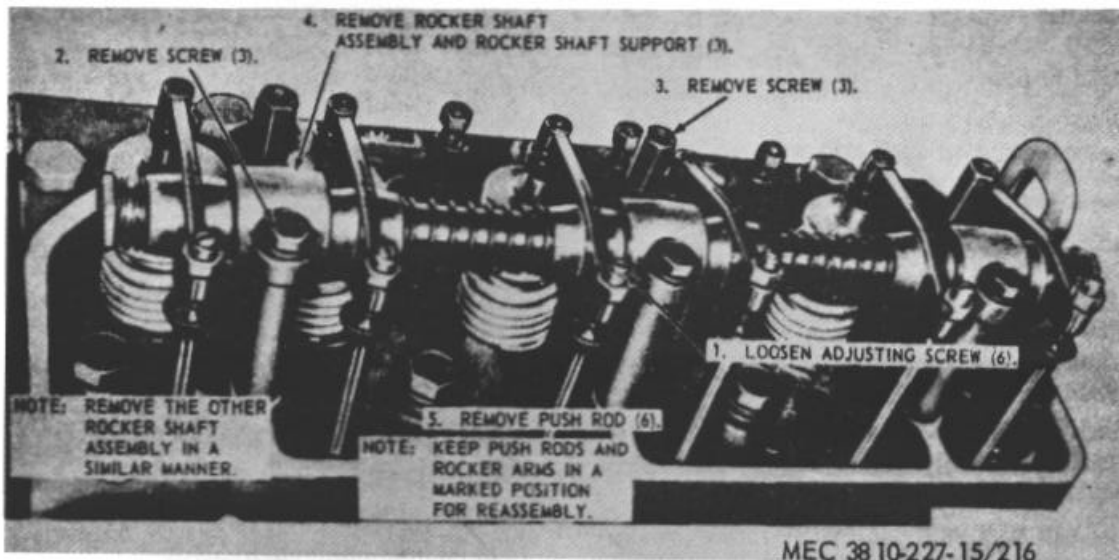

Figure 216. Carrier engine rocker arm shaft and pushrods assembly, removal and installation.

#### 419. Carrier Engine Rocker Arm and Push Rods Assembly Removal and Disassembly

##### a. Removal.

- (1) Remove the intake and exhaust manifolds (para. 169).
- (2) Remove the water manifold (para. 151).
- (3) Remove the spark plugs (para. 100).

- (4) Remove the rocker arm covers (para. 170).
- (5) Remove the carrier engine rocker arm and push rods assembly as instructed on figure 216.

b. Disassembly. Disassemble the carrier engine rocker arm and push rods assembly in numerical sequence as illustrated on figure 217.

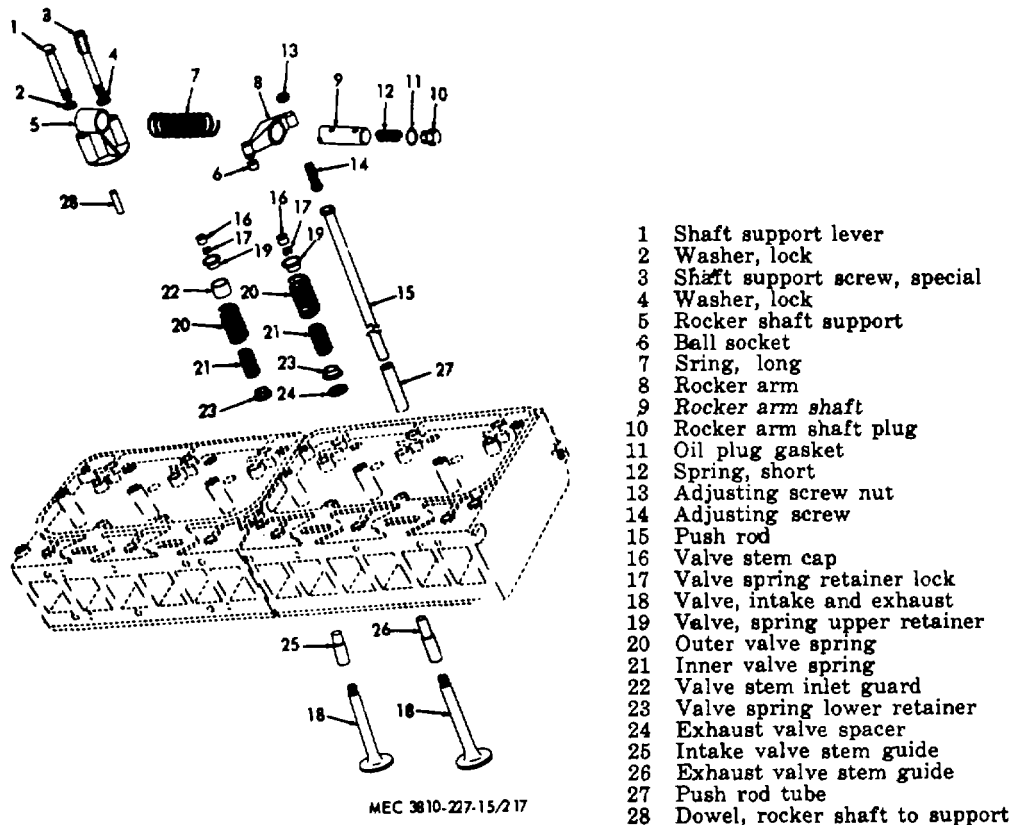

- 1 Shaft support lever
- 2 Washer, lock
- 3 Shaft support screw, special
- 4 Washer, lock
- 5 Rocker shaft support
- 6 Ball socket
- 7 Spring, long
- 8 Rocker arm
- 9 Rocker arm shaft
- 10 Rocker arm shaft plug
- 11 Oil plug gasket
- 12 Spring, short
- 13 Adjusting screw nut
- 14 Adjusting screw
- 15 Push rod
- 16 Valve stem cap
- 17 Valve spring retainer lock
- 18 Valve, intake and exhaust
- 19 Valve, spring upper retainer
- 20 Outer valve spring
- 21 Inner valve spring
- 22 Valve stem inlet guard
- 23 Valve spring lower retainer
- 24 Exhaust valve spacer
- 25 Intake valve stem guide
- 26 Exhaust valve stem guide
- 27 Push rod tube
- 28 Dowel, rocker shaft to support

Figure 217. Carrier engine rocker arm and push rod assembly, exploded view.

#### 420. Carrier Engine Rocker Arm and Push Rods Assembly Cleaning, Inspection, and Repair

a. *Cleaning.* Clean all parts with an approved cleaning solvent and dry thoroughly.

b. *Inspection and Repair.* Inspect all parts for excessive wear, defects, and damage. Replace or repair all damaged or defective parts. Inspect the rocker arm-to-shaft clearance. The clearance should measure from 0.0005 to 0.0015 inch.

#### 421. Carrier Engine Rocker Arm and Push Rods Assembly Reassembly and Installation

a. *Reassembly.* Reassemble the carrier engine rocker arm and push rods assembly in the reverse of the numerical sequence as illustrated on figure 217.

b. *Installation.*

- (1) Install the carrier engine rocker arm and push rods assembly as illustrated on figure 216.
- (2) Install the rocker arm covers (para. 170).
- (3) Install the spark plug (para. 100).
- (4) Install the water manifold (para. 151).
- (5) Install the intake and exhaust manifolds (para. 169).

### Section XXXIV. CARRIER ENGINE CYLINDER HEAD AND VALVES

#### 422. General

The carrier engine cylinder head consists of two sections, front and rear. The cylinder head houses the exhaust and intake valves. The exhaust valves are made of heat resistant steel.

#### 423. Carrier Engine Cylinder Head and Valves Removal and Disassembly

a. *Removal.*

- (1) Remove the carrier engine rocker arm and push rods assembly (para. 419).
- (2) Remove the carrier engine cylinder head and valves as instructed on figure 218.

b. *Disassembly.* Disassemble the cylinder head and valves in numerical sequence as illustrated on figure 219.

#### 424. Carrier Engine Cylinder Head and Valves Cleaning, Inspection, and Repair

a. *Cleaning.* Clean all parts in an approved cleaning solvent and dry thoroughly.

b. *Inspection and Repair.* Inspect all parts for excessive wear or damage. Inspect the valve springs for a minimum spring length of 2 3/4 inches at 85 to 95 pounds, and 2 19/32 inches at 41 to 49 pounds for the outer and inner springs respectively. Replace or repair all damaged or defective parts. The valve head diameter should be between 2.245 and 2.256 inches.

#### 425. Carrier Engine Cylinder Head and Valves Reassembly and Installation

a. *Reassembly.* Reassemble the cylinder head and valves in the reverse of the numerical sequence as illustrated on figure 219.

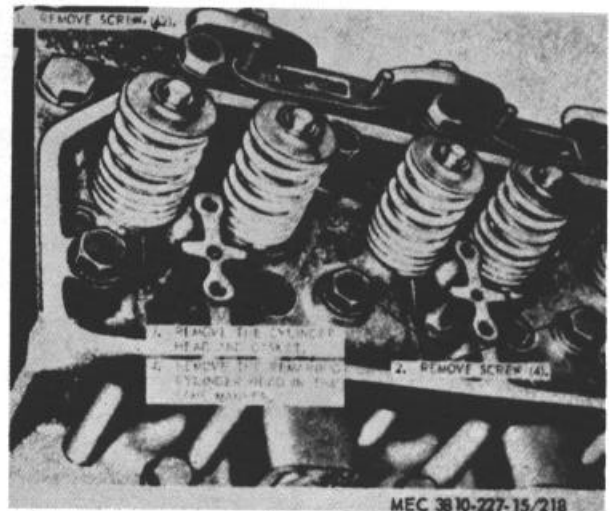
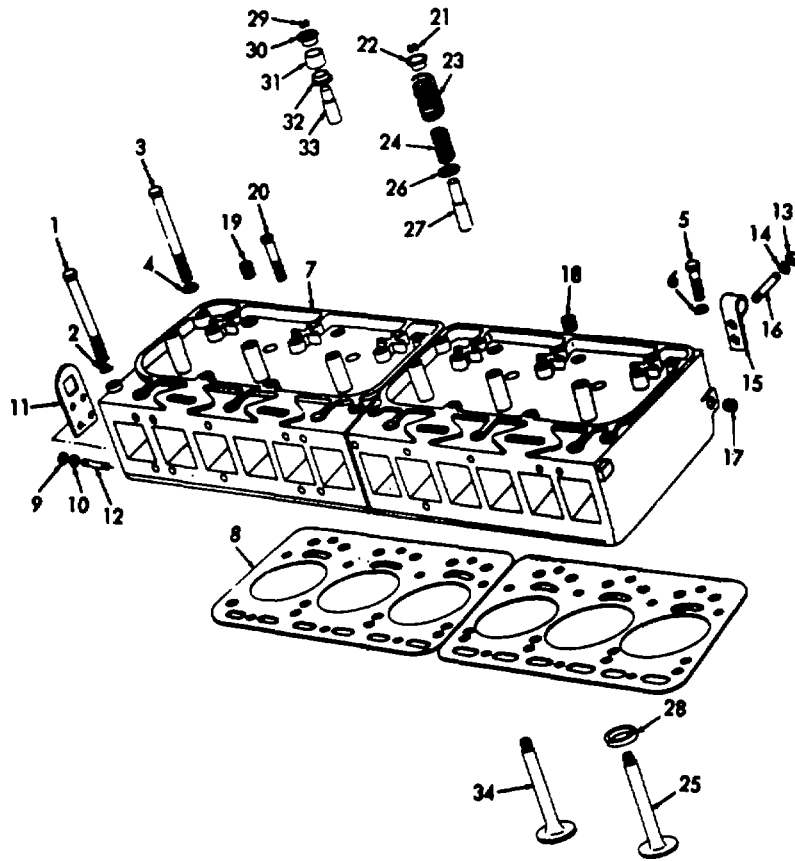

Figure 218. Carrier engine cylinder head and valves, removal and installation

AGO 6819A

b. Installation.

- (1) Install the cylinder head and valves as illustrated on figure 218.
- (2) Install the carrier engine rocker arm and push rods assembly (para. 421).



MEC 38 10-227- 15/219

- |                      |                                |                                |
|----------------------|--------------------------------|--------------------------------|
| 1 Screw, cap         | 13 Nut                         | 25 Exhaust valve               |
| 2 Lockwasher         | 14 Lockwasher                  | 26 Exhaust valve spacer        |
| 3 Screw, cap         | 15 Front lifting eye           | 27 Exhaust valve stem guide    |
| 4 Lockwasher         | 16 Stud                        | 28 Exhaust valve seat insert   |
| 5 Screw, cap         | 17 Plug                        | 29 Valve spring retainer lock  |
| 6 Lockwasher         | 18 Plug                        | 30 Valve spring upper retainer |
| 7 Rear cylinder head | 19 Plug                        | 31 Valve stem guard            |
| 8 Gasket             | 20 Screw, slotted head         | 32 Valve spring lower retainer |
| 9 Nut                | 21 Valve spring retainer lock  | 33 Intake valve stem guide     |
| 10 Lockwasher        | 22 Valve spring upper retainer | 34 Intake valve                |
| 11 Rear lifting eye  | 23 Outer valve spring          |                                |
| 12 Stud              | 24 Inner valve spring          |                                |

Figure 219. Carrier engine cylinder head and valves, exploded view.

### Section XXXV. CARRIER ENGINE OIL PAN

#### 426. General

The carrier engine oil pan is a steel pump type pan with an eighteen quart capacity. The engine is equipped with a measuring device to determine the quantity of oil available in the pan. An inspection cover is

provided to aid in making necessary adjustments on the oil pump within the engine block.



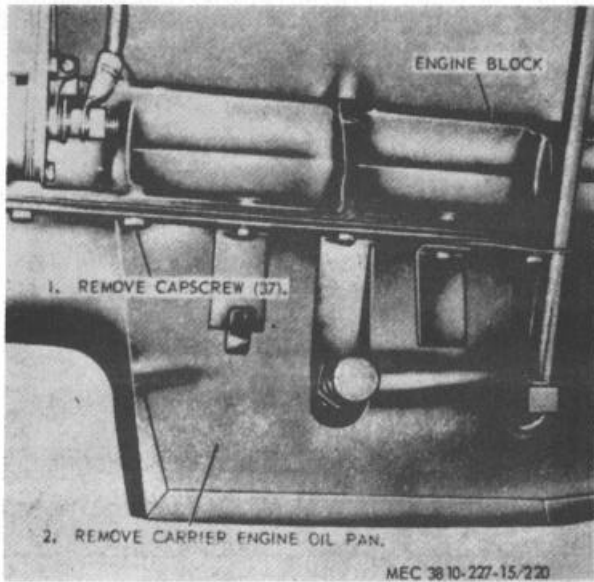

Figure 290. Carrier engine oil pan, removal and installation.

#### 427. Carrier Engine Oil Pan Removal and Disassembly

##### a. Removal.

- (1) Drain the crankcase.
- (2) Remove the handhole cover and gage rod.
- (3) Remove the carrier engine oil pan as instructed on figure 220.

b. *Disassembly.* Disassemble the carrier engine oil pan in numerical sequence as illustrated on figure 221.

#### 428. Carrier Engine Oil Pan Cleaning, Inspection and Repair

a. *Cleaning.* Clean all parts with an approved cleaning solvent and dry thoroughly.

b. *Inspection and Repair.* Inspect all parts for excessive wear or damage. Replace or repair all defective parts.

#### 429. Carrier Engine Oil Pan Reassembly and Installation

a. *Reassembly.* Reassemble the carrier engine oil pan in the reverse of the numerical sequence as illustrated on figure 221.

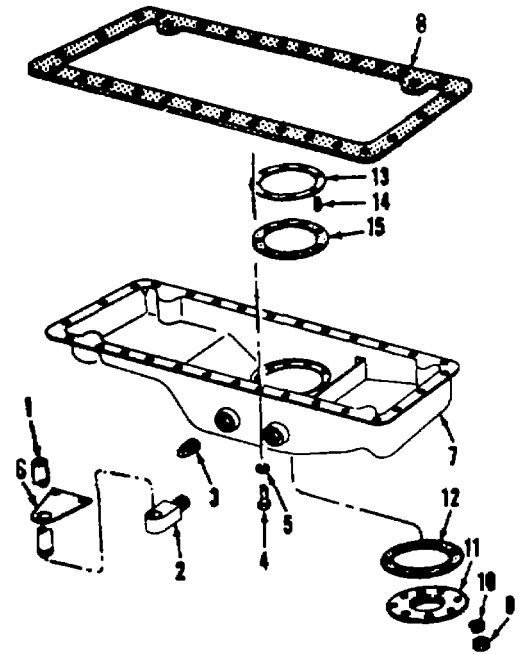

MEC 38 10-227-15/221

- 1 Oil tube
- 2 Oil tube adapter
- 3 Plug, pipe
- 4 Screw, cap
- 5 Washer, lock
- 6 Oil tube mounting bracket
- 7 Oil pan
- 8 Gasket
- 9 Nut, hex
- 10 Washer, lock
- 11 Handhole cover
- 12 Gasket
- 13 Handhole reinforcement ring
- 14 Stud
- 15 Gasket

Figure 221. Carrier engine oil pan, exploded view.

##### b. Installation.

- (1) Install the carrier engine oil pan as illustrated on figure 220.
- (2) Install the handhole cover and gage rod.
- (3) Fill the crankcase.

## Section XXXVI. CARRIER ENGINE OIL PUMP ASSEMBLY

### 430. General

The carrier engine oil pump is a gear-type pump that is spline-shaft driven from the accessory drive unit operating from the camshaft. The pump is equipped with a float-type screen through which all oil flows to the pump as it is drawn from the oil supply in the oil pan. An adjustable spring actuated plunger in the pump relief valve is equipped to vary the oil pressure to meet the engine requirements.

### 431. Carrier Engine Oil Pump Assembly Removal and Disassembly

#### a. Removal.

- (1) Remove the carrier engine oil pan (para. 427).
- (2) Remove the carrier engine oil pump assembly as instructed on figure 222.

b. *Disassembly.* Disassemble the carrier engine oil pump in numerical sequence as instructed on figure 223.

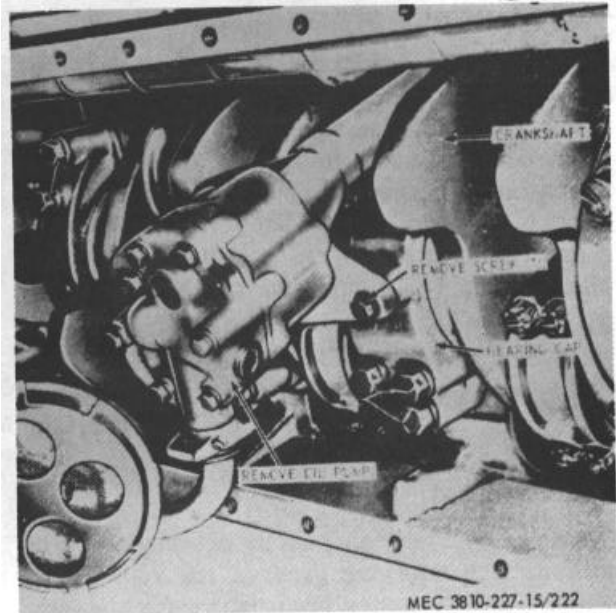
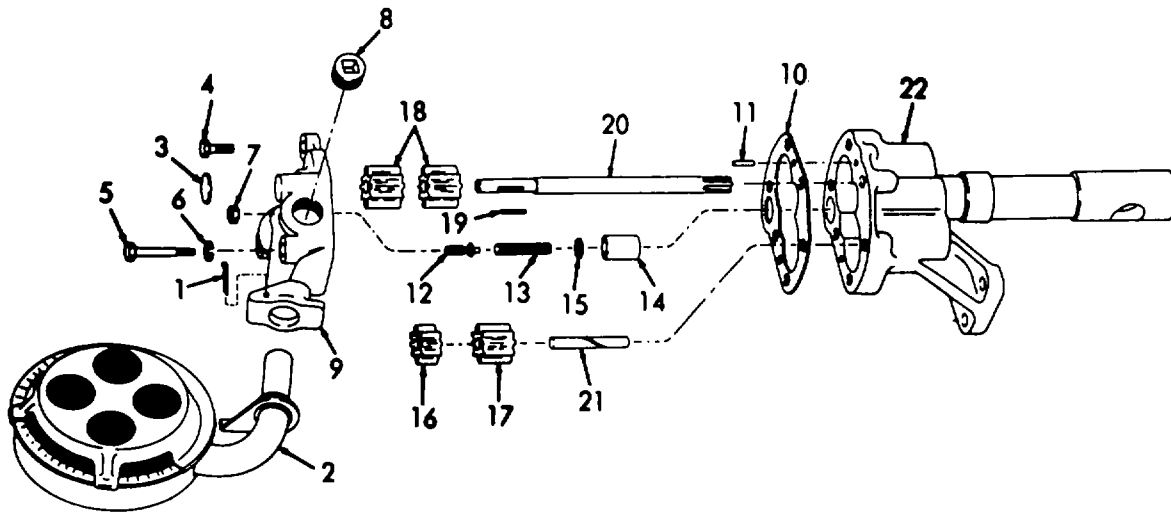

Figure 222. Carrier engine oil pump assembly, removal and installation.



1 Pin, cotter	7 Adjusting screw locknut	13 Relief valve plunger spring	18 Drive gear
2 Screened float	8 Plug, pipe	14 Relief valve plunger	19 Key
3 Plug	9 Pump body cover	15 Shim	20 Drive shaft
4 Screw, cap	10 Gasket	16 Lower idler gear	21 Idler gear shaft
5 Screw, cap	11 Pin	17 Upper idler gear	22 Pump body
6 Washer, lock	12 Relief valve adjusting screw		

Figure 223. Carrier engine oil pump assembly-exploded view.

#### 432. Carrier Engine Oil Pump Assembly Cleaning, Inspection, and Repair

a. *Cleaning.* Clean all parts with an approved cleaning solvent and dry thoroughly.

b. *Inspection and Repair.* Inspect all parts for excessive wear or damage. Inspect the gears to check for excessive backlash between teeth. There should not be more than 0.010 inch between teeth. Inspect the clearance between the gear teeth and pump body. The clearance should be between 0.003 and 0.004 inch. Replace or repair all defective parts.

### Section XXXVII. CARRIER ENGINE CONNECTING ROD AND PISTON ASSEMBLIES

#### 434. General

The carrier engine pistons are made of aluminum alloy and are grooved for four piston rings. The two upper grooves are for the compression rings, the second groove also holds an expansion ring. The two lower grooves are for the oil rings, the fourth groove also holds an expansion ring. The piston pins are held in place in the piston with two retaining rings to prevent contact with the cylinder walls. The connecting rods are drilled for lubrication. The connecting rods and caps are matched sets and are marked with matched numbers. Always replace rods and caps as a matched set.

#### 433. Carrier Engine Oil Pump Assembly Reassembly and Installation

a. *Reassembly.* Reassemble the carrier engine oil pump assembly in the reverse of the numerical sequence as illustrated on figure 223.

b. *Installation.*

- (1) Install the carrier engine oil pump assembly as illustrated on figure 222.
- (2) Install the carrier engine oil pan (para. 429).

#### 435. Carrier Engine Connecting Rod and Piston Assemblies Removal and Disassembly

a. *Removal.*

- (1) Remove the carrier engine cylinder head (para. 423).
- (2) Remove the carrier engine oil pan (para. 427).
- (3) Remove the connecting rod and piston assemblies as instruction figure 224.

b. *Disassembly.* Disassemble the carrier engine connecting rod and piston assemblies in numerical sequence as illustrated on figure 225.

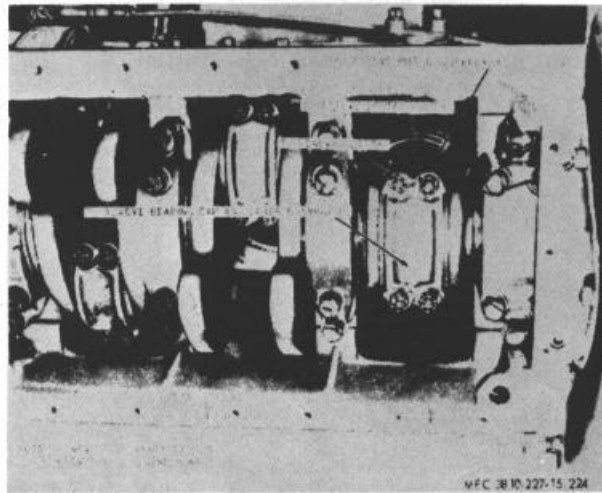
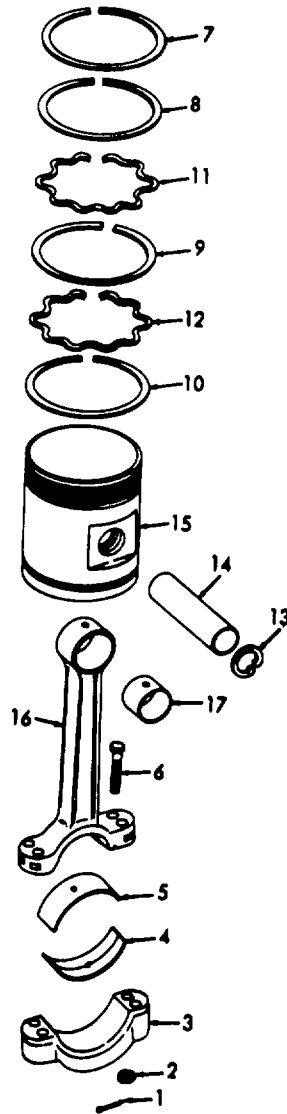

Figure 224. Carrier engine piston and connecting rod assemblies, removal and installation

AGO 6819A



MEC 3810-227-15/225

- |                 |                             |                   |
|-----------------|-----------------------------|-------------------|
| 1 Pin, cotter   | 7 Piston ring (compression) | 13 Retaining ring |
| 2 Nut           | 8 Piston ring (compression) | 14 Piston pin     |
| 3 Bearing cap   | 9 Piston ring (compression) | 15 Piston         |
| 4 Lower bearing | 10 Oil ring                 | 16 Connecting rod |
| 5 Upper bearing | 11 Expander ring            | 17 Bushing        |
| 6 Bolt, special | 12 Expander ring            |                   |

Figure 225. Carrier engine piston and connecting rod, exploded view.

#### 436. Carrier Engine Connecting Rod and Piston Assemblies Cleaning, Inspection, and Repair

a. *Cleaning.* Clean all parts with an approved cleaning solvent and dry thoroughly.

b. *Inspection and Repair.*

- (1) The standard finished size of the piston pin is 4.524 to 4.539 inches long, diameter is 1.7498 to 1.7500 inches. Fit in piston is 0.0001 to 0.0002

inch, and 0.0003 to 0.0007 inch in rod bushing. The rod bushing is 1-15-/16 inches long, 1.941 to 1.943 inches outside diameter, and 1.7503 to 1.7505 inches inside diameter.

- (2) The correct piston ring gap clearance for this engine is 0.017 to 0.032 inch. Install the piston ring in cylinder. Invert the piston in the cylinder and push against the ring until the ring is square with the cylinder bore. Remove the piston.
- (3) Check the piston ring gap with a feeler gage. If the gage exceeds 0.032 inch, replace the ring. If the gap is less than 0.017 inch, file the end of the ring until proper clearance is obtained.
- (4) Check the piston ring groove clearance. The correct clearance for first ring is 0.0036 to 0.0055 inch, second and third rings are 0.0025 to 0.0045 inch, and the fourth ring is 0.0015 to 0.0036 inch. Install the piston rings on the piston and attempt to slide the feeler gage in the groove between the piston ring and piston land.
- (5) If the feeler gage will not slide in the groove between the ring and land or if the rings are sprung, distorted, or excessively worn, replace the rings.
- (6) Fit the piston in the cylinder bore with an 0.008 inch feeler gage. Attach the feeler gage to a spring scales.

- (7) Invert the piston and feeler gage over the cylinder. Place the feeler gage and the piston in the cylinder. Withdraw the feeler gage and observe the scale reading.
- (8) The proper scale reading is from 5 to 10 pounds. Test the cylinder bore in several places.
- (9) The proper thickness of the rod bearings is 0.0948 to 0.0953 inch. The wear limit is 0.004 inch.
- (10) Replace or repair all damaged or defective parts. Always replace bearings as matched sets.

#### **437. Carrier Engine Connecting Rod and Piston Assemblies, Reassembly and Installation**

a. *Reassembly.* Reassemble the carrier engine connecting rod and piston assemblies in the reverse of the numerical sequence as illustrated on figure 225.

b. *Installation.*

- (1) Install the carrier engine connecting rod and piston assemblies as illustrated on figure 224.
- (2) Install the carrier engine oil pan (para. 429).
- (3) Install the carrier engine cylinder head (para. 426).

### **Section XXXVIII. CARRIER ENGINE CLUTCH HOUSING**

#### **438. General**

A cast steel clutch housing incloses the clutch mechanism. The housing provides access to the clutch for inspection and adjustments as well as for clutch bearing lubrication. Remote operation of the clutch is by linkage connected to a shaft operated yoke located in the clutch housing.

#### **439. Carrier Engine Clutch Housing Removal and Disassembly**

a. *Removal.*

- (1) Disconnect the propeller shaft (para. 244).
- (2) Disconnect the transmission controls (paras. 245 and 246).
- (3) Remove the carrier transmission (para. 471).

AGO 6819A

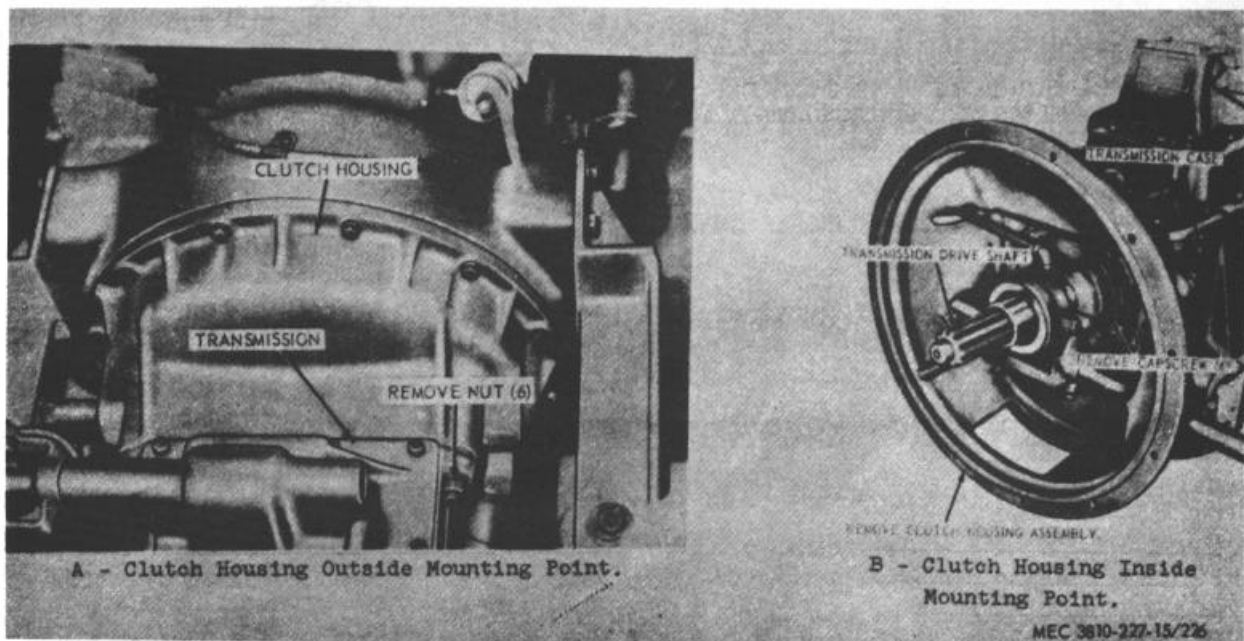
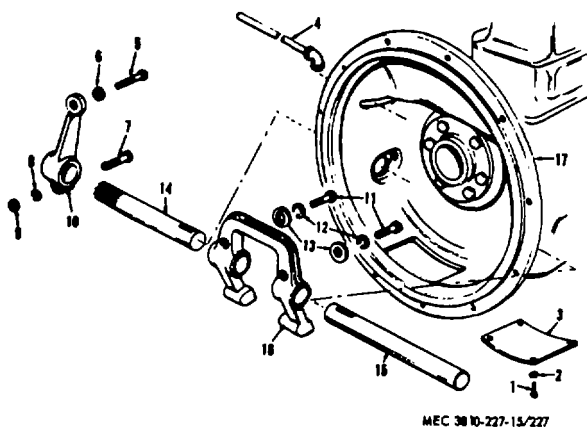

Figure 226. Carrier engine clutch housing, removal and installation.



- |              |                 |
|--------------|-----------------|
| 1 Screw      | 10 Lever        |
| 2 Washer     | 11 Screw        |
| 3 Plate      | 12 Lockwasher   |
| 4 Lube tube  | 13 Key          |
| 5 Set screw  | 14 Shaft        |
| 6 Jam nut    | 15 Shaft        |
| 7 Screw      | 16 Yoke         |
| 8 Lockwasher | 17 Bell housing |
| 9 Nut        |                 |

Figure 227. Carrier engine clutch housing, exploded view.

(4) Remove the carrier engine clutch housing as instructed on figure 226.

b. *Disassembly.* Disassemble the carrier engine clutch housing in numerical sequence as illustrated on figure 227.

#### 440. Carrier Engine Clutch Housing Cleaning, Inspection, and Repair

a. *Cleaning.* Clean all parts with an approved cleaning solvent and dry thoroughly.

b. *Inspection and Repair.* Inspect all parts for excessive wear and damage. Replace or repair all defective parts.

#### 441. Carrier Engine Clutch Housing Reassembly and Installation

a. *Reassembly.* Reassemble the carrier engine clutch housing in the reverse of the numerical sequence as illustrated on figure 227.

b. *Installation.*

- (1) Install the carrier engine clutch housing as illustrated on figure 226.
- (2) Install the carrier transmission (para. 473).

- (3) Connect the transmission controls (paras. 245, 246).
- (4) Connect the propeller shaft (para. 244).

**Section XXXIX. CARRIER ENGINE CLUTCH ASSEMBLY**

**442. General**

A push-type, dry-disk, multiple-levered clutch of adjustable type construction is used on the carrier engine.

The clutch assembly is fastened to the engine flywheel and an independently driven disk revolves the clutch unit when the

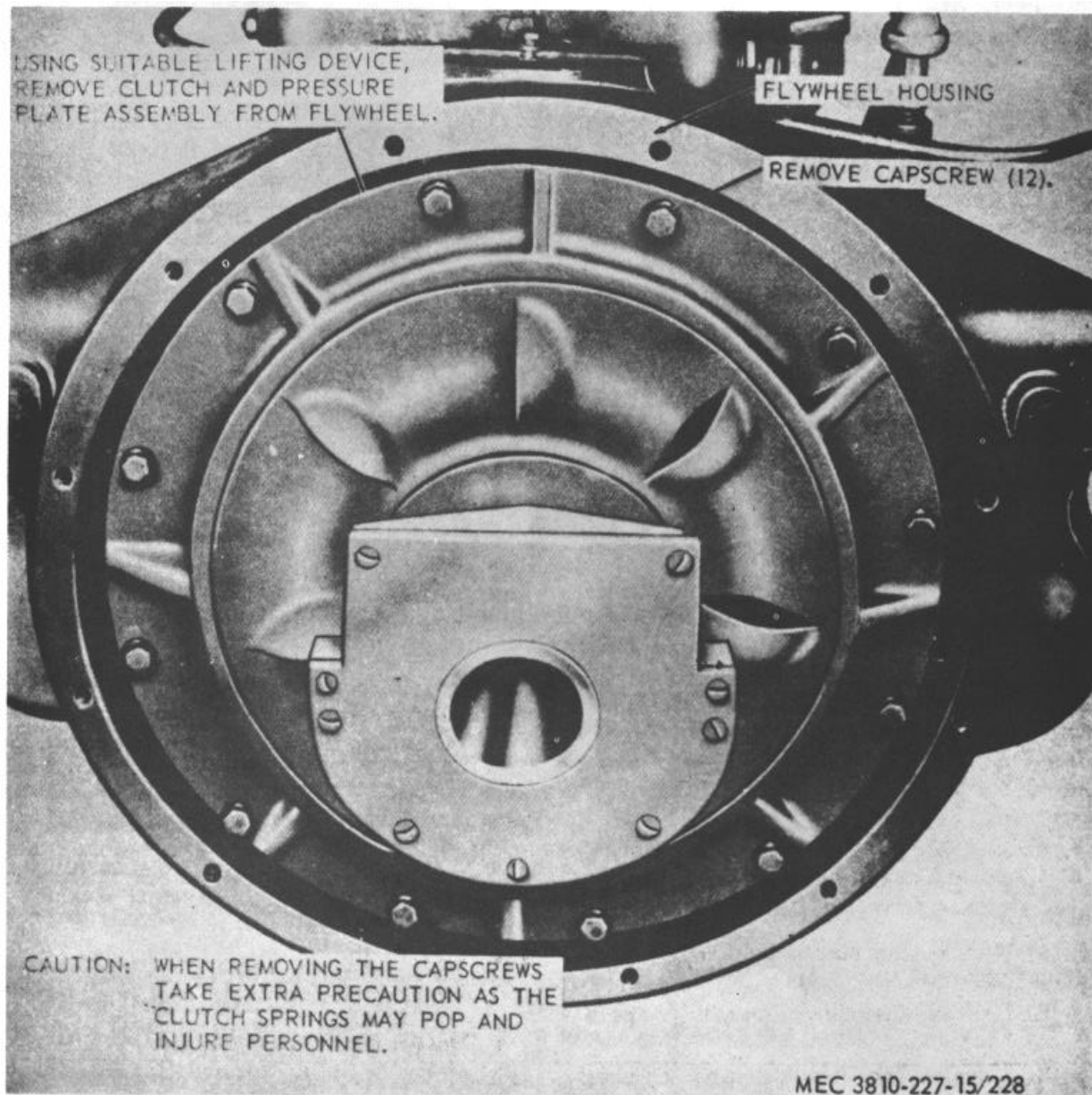

**Figure 228. Carrier engine clutch and pressure plate, removal and installation.**

clutch is engaged. The facing wear of the driven disks is compensated by adjusting the threaded internal adjusting ring to restore the original spring pressure.

#### **443. Carrier Engine Clutch Assembly Removal and Disassembly**

##### *a. Removal.*

- (1) Disconnect the propeller shaft (para. 244).
- (2) Remove the clutch housing (para. 489).
- (3) Remove the carrier engine clutch assembly as instructed on figure 228.

*b. Disassembly.* Disassemble the carrier engine clutch assembly in numerical sequence as illustrated on B, figure 103.

#### **444. Carrier Engine Clutch Assembly Cleaning, Inspection and Repair**

*a. Cleaning.* Clean the disk assembly with a dry cloth. Clean remaining parts with an approved cleaning solvent and dry thoroughly.

*b. Inspection and Repair.* Inspect all parts for excessive wear or damage. Replace or repair all defective or damaged parts. The proper clearance between the pressure plate driving lugs and slots of the flywheel ring is from 0.004 to 0.008 inches.

#### **445. Carrier Engine Clutch Assembly Reassembly and Installation**

*a. Reassembly.* Reassemble the carrier engine clutch assembly in the reverse of the numerical, sequence as illustrated on B, figure 103.

##### *b. Installation.*

- (1) Install the carrier engine clutch assembly as illustrated on figure 228.
- (2) Install the clutch housing (para. 441).
- (3) Connect the propeller shaft (para. 244).

### **Section XL. CARRIER ENGINE FLYWHEEL AND FLYWHEEL HOUSING**

#### **446. General**

The carrier engine flywheel is attached to the crankshaft flange with six capscrews, lockwashers, and a lockwire. One of the cap screws is offset 1/16 inch. A corresponding hole is located in the crankshaft flange so the flywheel can be assembled in but one position. It is very important to tighten the flywheel capscrews securely. The flywheel housing provides support for mounting the clutch housing and transmission assemblies as well as affording protection to the clutch mechanism and flywheel ring gear.

#### **447. Carrier Engine Flywheel and Flywheel Housing Removal and Disassembly**

##### *a. Remove.*

- (1) Remove the starter assembly (para. 102).
- (2) Remove the clutch assembly (para. 448).
- (3) Remove the flywheel and flywheel housing as instructed on figure 229.

*b. Disassembly.* Disassemble the flywheel and flywheel housing in numerical sequence as illustrated on figure 230.

#### **448. Carrier Engine Flywheel and Flywheel Housing, Cleaning, Inspection, and Repair**

*a. Cleaning.* Clean all parts with an approved cleaning solvent and dry thoroughly.

*b. Inspection and Repair.* Inspect all parts for excessive wear and damage. Replace or repair all defective parts. Maximum run-out of the flywheel should not exceed 0.002 indicator reading.

#### **449. Carrier Engine Flywheel and Flywheel Housing Reassembly and Installation**

*a. Reassembly.* Reassemble the flywheel and flywheel housing in the reverse of the numerical sequence as illustrated on figure 230.



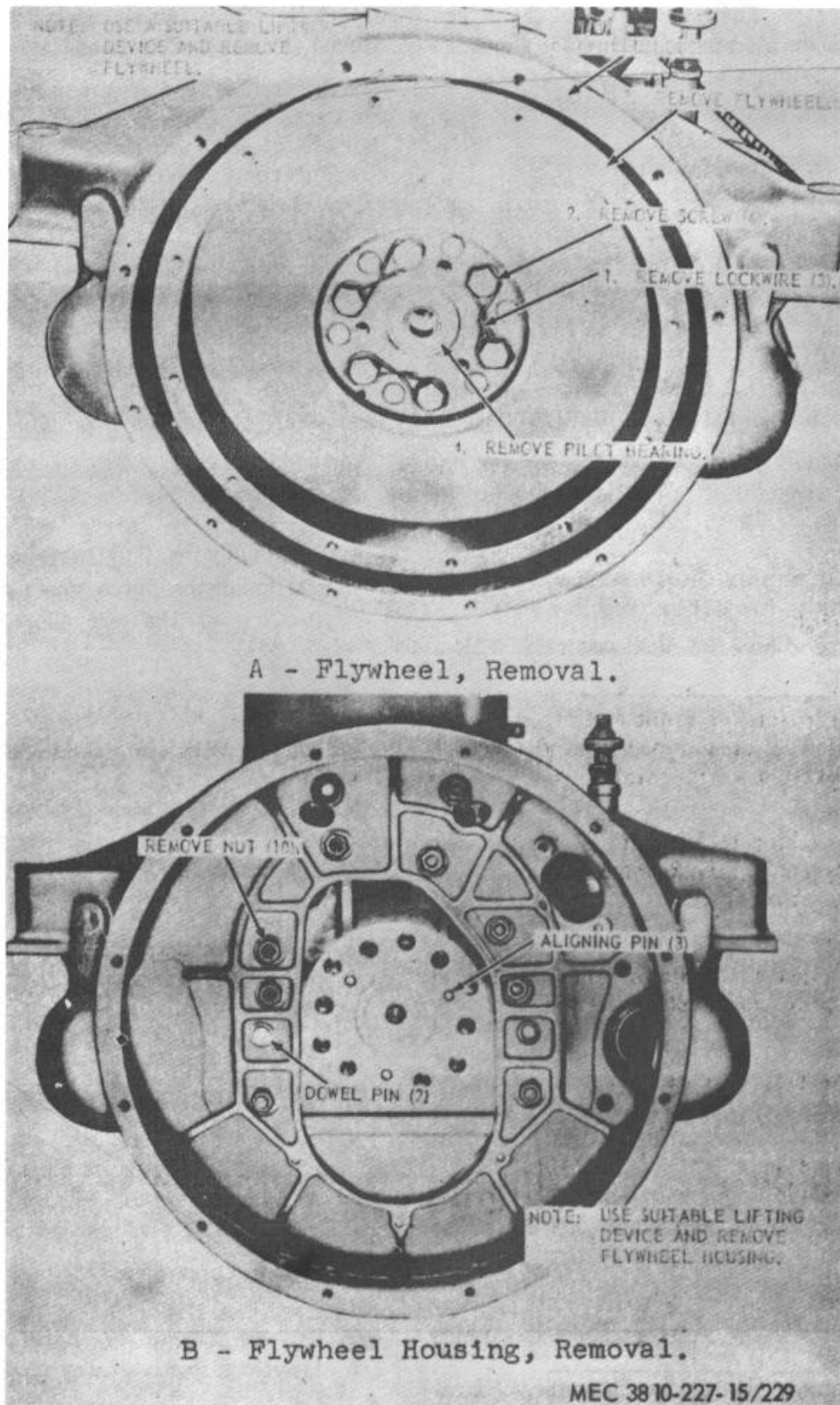
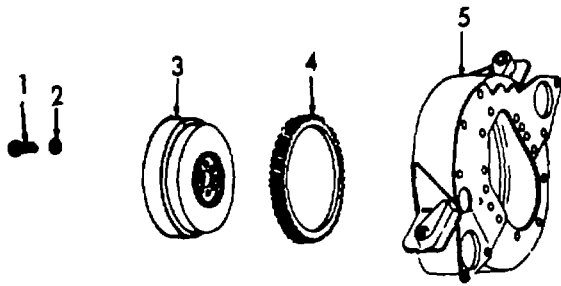

Figure 229. Carrier engine flywheel and flywheel housing, removal and installation

AGO 6819A



MEC 3810-227-15/230

- |                |                    |
|----------------|--------------------|
| 1 Screw, cap   | 4 Ring gear        |
| 2 Washer, lock | 5 Flywheel housing |
| 3 Flywheel     |                    |

Figure 230. Carrier engine flywheel, ring gear, and flywheel housing, exploded view.

### Section XLI. CARRIER ENGINE VIBRATION DAMPER AND PULLEY ASSEMBLY

#### 450. General.

The carrier engine vibration damper is dynamically balanced and attached to the drive pulley mounted on the front end of the crankshaft. The vibration damper is used to eliminate the vibration of the crankshaft.

#### 451. Carrier Engine Vibration Damper and Pulley Assembly Removal and Disassembly

##### a. Removal.

- (1) Remove the radiator from the carrier engine (para. 407).

- (2) Remove the carrier engine vibration damper and pulley assembly from the crankshaft as illustrated on figure 231.

b. Disassembly. Disassemble the carrier engine vibration damper and pulley assembly in the numerical sequence as instructed on figure 232.

#### 452. Carrier Engine Vibration Damper and Pulley Assembly Cleaning, Inspection, and Repair

a. Cleaning. Clean all parts with an approved cleaning solvent.

##### b. Inspection and Repair.

- (1) Inspect the damper for breaks, cracks, and other damage. Replace defective vibration damper.
- (2) Inspect the pulley for breaks, cracks, and other damage. Replace defective pulley.
- (3) Inspect the remaining parts for damaged threads, cracks, bends, breaks and other damage.

#### 453. Carrier Engine Vibration Damper and Pulley Assembly Reassembly and Installation

a. Reassembly. Reassemble the carrier engine vibration damper and pulley assembly oil

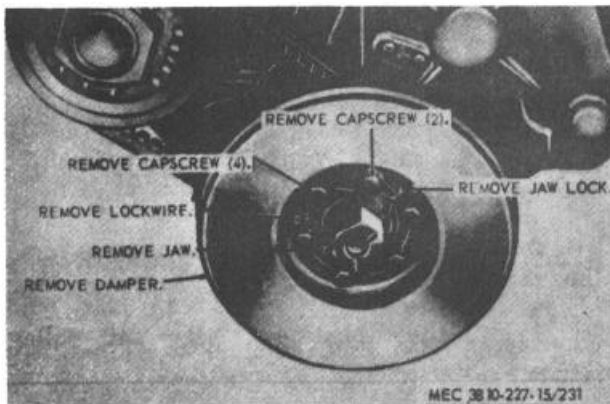

Figure 231. Carrier engine vibration damper and pulley assembly, removal and installation.

AGO 6819A

the crankshaft in the reverse of the numerical sequence as instructed on figure 232.

b. *Installation.*

- (1) Install the vibration damper and pulley assembly as illustrated on figure 231.
- (2) Install the radiator on the carrier engine (para. 409).

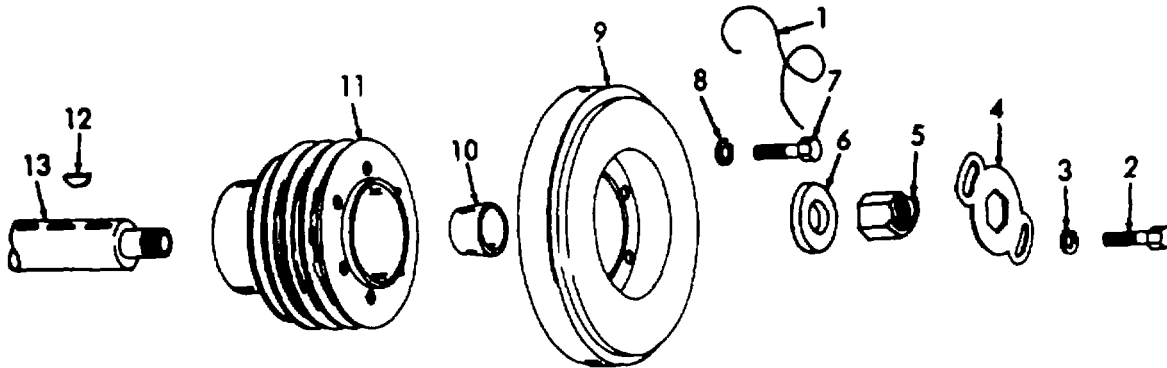

MEC 3810-227-15/232

- |                |                    |                 |
|----------------|--------------------|-----------------|
| 1 Lockwire     | 6 Jaw washer       | 11 Pulley       |
| 2 Screw, cap   | 7 Screw, cap       | 12 Woodruff key |
| 3 Washer, lock | 8 Washer, lock     | 13 Crankshaft   |
| 4 Jaw lock     | 9 Vibration damper |                 |
| 5 Jaw          | 10 Split collar    |                 |

Figure 232. Carrier engine vibration damper and pulley assembly, exploded view.

**Section XLII. CARRIER ENGINE TIMING GEARS**

**454. General**

The carrier engine timing gears consist of the crankshaft and camshaft gears which are helically cut to provide greatest meshing surface. The crankshaft gear drives the camshaft gear at one-half engine speed.

**455. Carrier Engine Timing Gears Removal**

- a. Remove the carrier engine assembly (para. 298).
- b. Remove the fan and fan belts (paras. 145 and 146).
- c. Remove the accessory drive (para. 403).
- d. Remove the oil pump (para. 431).
- e. Remove the flywheel housing (para. 447).
- f. Remove the cylinder head and valves (para. 423).
- g. Remove the vibration damper and pulley (para. 451).

h. Remove the carrier engine timing gears as instructed on figure 233.

**456. Carrier Engine Timing Gears Cleaning and Inspection**

- a. Clean all parts with an approved cleaning solvent and dry thoroughly.
- b. Inspect all parts for excessive wear or damage. Replace all defective parts. Always replace gears in pairs.

**457. Carrier Engine Timing Gears Installation**

- a. Install the carrier engine timing gears as illustrated on figure 233.
- b. Install the vibration damper and pulley (para. 463).
- c. Install the cylinder head and valves (para. 425).

AGO 6819A



Figure 233. Carrier engine timing gears, removal and installation.

- d. Install the flywheel housing (para. 449).
- e. Install the oil pump (para. 433).
- f. Install the accessory drive (para. 405).

- g. Install the fan and fan belts (paras. 145 and 146).
- h. Install the carrier engine assembly (para. and 146).

### Section XLIII. CARRIER ENGINE CAMSHAFT

#### 458. General

A one-piece drop-forged camshaft is used in the carrier engine and is supported by replaceable bushings. An integral gear midway between the ends of the camshaft provides the drive for the accessory drive that drives the engine oil pump and other accessories.

#### 459. Carrier Engine Camshaft Removal and Disassembly

##### a. Removal.

- (1) Remove the timing gears (para. 455).
- (2) Remove the carrier engine camshaft as instructed on figure 234.

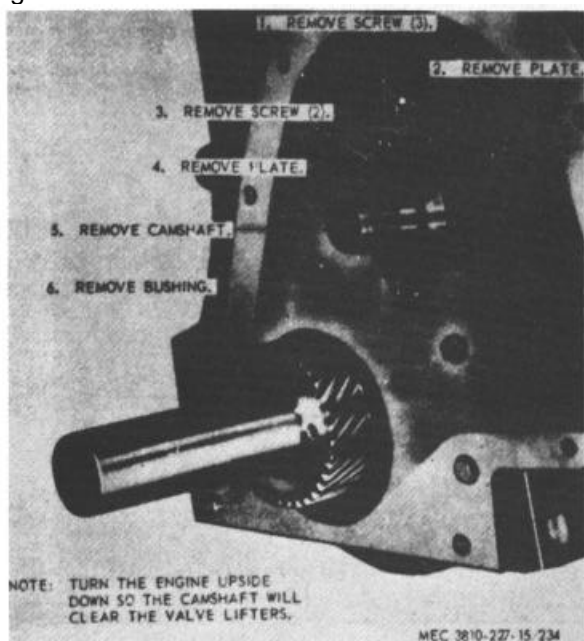

**Figure 234. Carrier engine camshaft and bushing, removal and installation.**

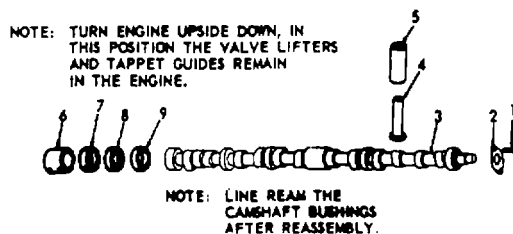

- 1 Screw, machine
- 2 Thrust plate
- 3 Camshaft
- 4 Valve tappet
- 5 Valve tappet guide
- 6 Center camshaft bushing
- 7 Rear camshaft bushing
- 8 Front camshaft bushing
- 9 Intermediate camshaft bushing

**Figure 235. Carrier engine camshaft, bushings, and valve lifter, exploded view.**

b. *Disassembly.* Disassemble the camshaft in numerical sequence as instructed on figure 235.

#### 460. Carrier Engine Camshaft Cleaning and Inspection

- a. Clean all parts with an approved cleaning solvent and dry thoroughly.
- b. Inspect all parts for excessive wear or damage.
- c. Inspect the camshaft bearing journal for diameter of 2.2470 inch minimum to 2.2480 inch maximum.
- d. Inspect the camshaft end play for a clearance of 0.004 inch minimum to 0.006 inch maximum.
- e. Inspect the camshaft bushings for tolerance of 2.2495 inch minimum to 2.2500 inch maximum.
- f. Replace all defective parts.

#### 461. Carrier Engine Camshaft Reassembly and Installation

- a. *Reassembly.* Reassemble the camshaft in reverse of the numerical sequences as instructed on figure 235.
- b. *Installation.*

- (1) Install the carrier engine camshaft as illustrated on figure 234.
- (2) Install the timing gears (para. 457).

### Section XLIV. CARRIER ENGINE CRANKSHAFT AND MAIN BEARINGS

#### 462. General

The carrier engine crankshaft is a counterbalanced throw-type, drop forging. The crankshaft supports the connecting rods and pistons along its length. At the forward end is located the crankshaft drive gear that drives the camshaft gear. A flywheel is mounted to the rear end of the crankshaft. Bearing caps support the crankshaft within the crankcase. The primary purpose of the crankshaft is to convert the thrust force from the piston and connecting rod assemblies to torque power.

#### 463. Carrier Engine Crankshaft and Main Bearings Removal and Disassembly

##### a. Removal.

- (1) Remove the carrier engine (para. 298).
- (2) Remove the flywheel housing (para. 447).

- (3) Remove the oil pump (para. 431).
- (4) Remove the pistons and connecting rods (para. 435).

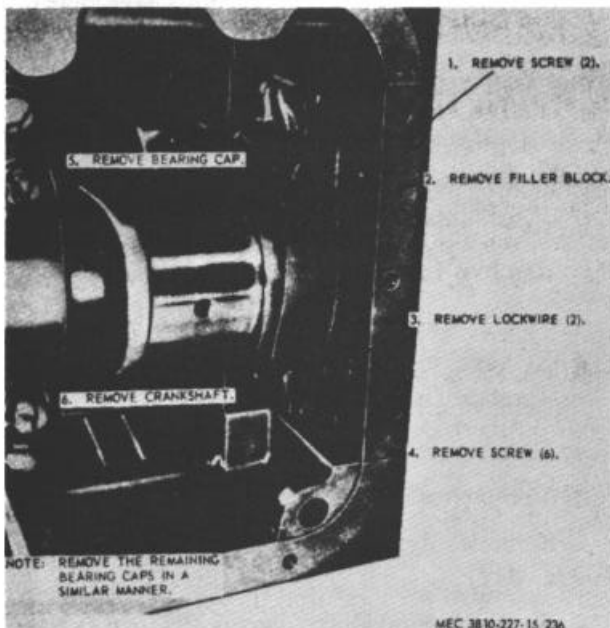
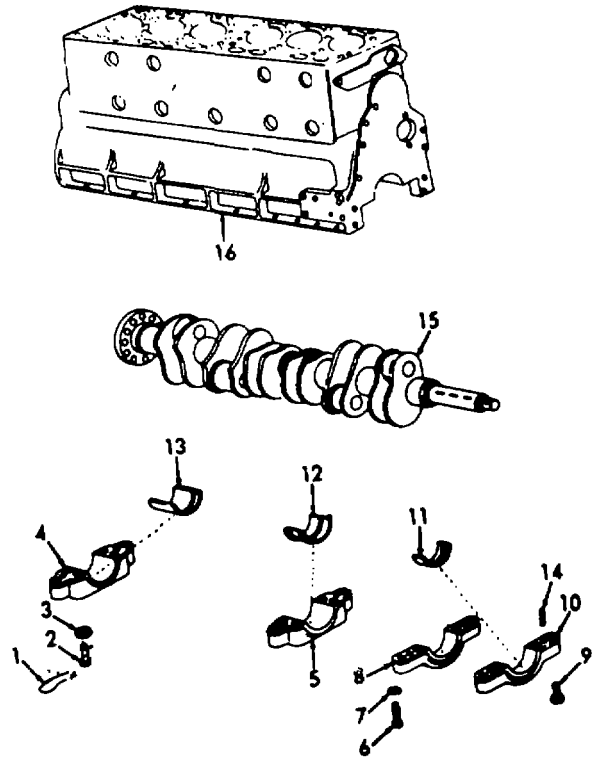

Figure 236. Carrier engine crankshaft and main bearings, removal and installation.



- MEC 3810-227-15/237
- 1 Lockwire
  - 2 Screw, cap
  - 3 Washer, flat
  - 4 Rear main bearing cap
  - 5 Center main bearing cap
  - 6 Screw, cap
  - 7 Washer, flat
  - 8 Intermediate main bearing cap
  - 9 Screw, cap
  - 10 Front main bearing cap
  - 11 Front and intermediate bearing
  - 12 Center bearing
  - 13 Rear bearing
  - 14 Dowel pin
  - 15 Crankshaft
  - 16 Engine block

Figure 237. Carrier engine crankshaft and main bearings, exploded view.

- (5) Remove the timing gears (para. 455).
- (6) Remove the carrier engine crankshaft and main bearings as instructed on figure 236.

*b. Disassembly.* Disassemble the carrier engine crankshaft and main bearings in numerical sequence as illustrated on figure 237.

#### **464. Carrier Engine Crankshaft and Main Bearings Cleaning, Inspection and Repair**

*a. Cleaning.* Clean all parts with an approved cleaning solvent and dry thoroughly.

*b. Inspection and Repair.*

- (1) Inspect the crankshaft for scored or damaged bearing journals, cracks, breaks, or other damage. Replace a defective crankshaft as necessary.
- (2) Inspect the connecting rod bearings and crankshaft main bearings for scores, cracks, breaks, or excessive wear.
- (3) Inspect the bearing caps for breaks, cracks, or other damage. Replace a defective bearing cap as necessary.
- (4) Inspect the crankshaft main bearing journals for a diameter of 3.749 inch minimum to 3.750 inch.

maximum. The main journal limits are 0.002 inch minimum to 0.003 inch maximum.

- (5) Inspect the crankshaft end play for 0.005 inch minimum to 0.008 inch maximum.
- (6) Inspect the crank pin. The diameter should be between 3.499 inch minimum and 3.500 inch maximum.

#### **465. Carrier Engine Crankshaft and Main Bearings Reassembly and Installation**

*a. Reassembly.* Reassemble the carrier engine crankshaft and main bearings in the reverse of the numerical sequence as illustrated on figure 237.

*b. Installation.*

- (1) Install the crankshaft and main bearings as illustrated on figure 286.
- (2) Install the timing gears (para. 457).
- (8) Install the pistons and connecting rods (para. 437).
- (4) Install the oil pump (para. 438).
- (5) Install the flywheel housing (para. 449).
- (6) Install the carrier engine (para. 298).

### **Section XLV. CARRIER ENGINE BLOCK**

#### **466. General**

The carrier engine block is a solid, one-piece, iron alloy casting. It houses the crankshaft, camshaft, connecting rods, pistons, and valves.

The block has large water jackets which surround the cylinders to provide sufficient cooling.

The intake valve seats are ground on the cylinder block surface. The exhaust valve seats are replaceable. Drilled oil passages carry oil under pressure to all bearings and moving parts requiring lubrication.

#### **467. Carrier Engine Block Removal**

*a.* Remove the carburetor, distributor, governor, generator, starter, generator regulator, 256 water pump, oil filters and spark plugs (paras. 86, 98, 87, 105, 102, 106, 149, 161, and 100).

- b.* Remove engine from carrier (para. 298).
- c.* Remove the radiator (para. 407).
- d.* Remove cylinder head (para. 428).
- e.* Remove oil pan (para. 427).
- f.* Remove oil pump (para. 481).
- g.* Remove valves (para. 428).
- h.* Remove pistons (para. 435).
- i.* Remove flywheel and flywheel housing (para. 447).
- j.* Remove crankshaft (para. 468).
- k.* Remove camshaft (para. 459).

#### **468. Carrier Engine Block Cleaning and Inspection**

- a. Soak the engine block in a strong caustic solvent for two hours; clean with live steam.
- b. Clean and blow out all oil and water passages with compressed air.
- c. Inspect the engine block for cracks, breaks, scored cylinder walls, and worn machined surfaces of the block. Check with straight edge and feeler gage. If machined surfaces are worn or warped more than 0.010 inch, replace block as necessary.
- d. Inspect all threaded holes for damaged or elongated holes. Replace all freeze plugs.
- e. Inspect cylinder diameter for 5.375 inch minimum to 5.377 inch maximum.
- f. Inspect the block main bearing bore for 4.002 inch minimum to 4.003 inch maximum.

#### **469. Carrier Engine Block Installation**

- a. Install the camshaft (para. 461).
- b. Install the crankshaft (para. 465).
- c. Install the flywheel housing and flywheel (para. 449).
- d. Install the pistons (para. 437).
- e. Install the valves (para. 425).
- f. Install the oil pump (para. 433).
- g. Install the oil pan (para. 429).
- h. Install the cylinder head (para. 425).
- i. Install the radiator (para. 409).
- j. Install the engine in carrier (para. 298).
- k. Install the oil filter, water pump, spark plugs, generator regulator, starter, generator, governor, distributor, and carburetor (paras. 161, 149, 100, 106, 102, 105, 87, 98, and 86).

### **Section XLVI. CARRIER TRANSMISSION ASSEMBLY**

#### **470. General**

The carrier transmission is mounted on the clutch housing of the carrier engine assembly. The transmission is a combination sliding and constant mesh unit. It incorporates five forward speeds and one reverse speed. Engine torque delivered to the transmission through the clutch is changed to the desired rate and then transmitted to the transfer case by means of a propeller shaft. The transmission gears are machined of a special alloy steel and then heat-treated. The gears, shaft, and bearings operate constantly in an oil bath. The entire transmission is enclosed.

#### **471. Carrier Transmission Assembly Removal and Disassembly**

##### *a. Removal.*

- (1) Drain the transmission assembly.
- (2) Disconnect the propeller shaft (para. 244).
- (3) Remove the carrier transmission assembly as instructed on figure 238.
- (4) Remove the carrier engine clutch housing as instructed on figure 226.

##### *b. Disassembly.*

- (1) Removal and disassembly of remote control assembly (A, fig. 239).
  - (a) Remove remote control assembly from transmission.
  - (b) Remove snap ring (18), Items (16 & 17) may now be removed as an assembly. Clevis pins (1 & 2) may be removed.
  - (c) Remove locking screws (4) and keys (9) from both shift fingers (10 & 11). Remove rocker shaft (6).
  - (d) When clevis pin in item (3) is removed the universal lever (14) and the outside shift finger (11) and boot (18) will be accessible, cut lockwires (12).
  - (e) Remove the snap ring (5) only if it is necessary to replace the pivot anchor bracket (3).



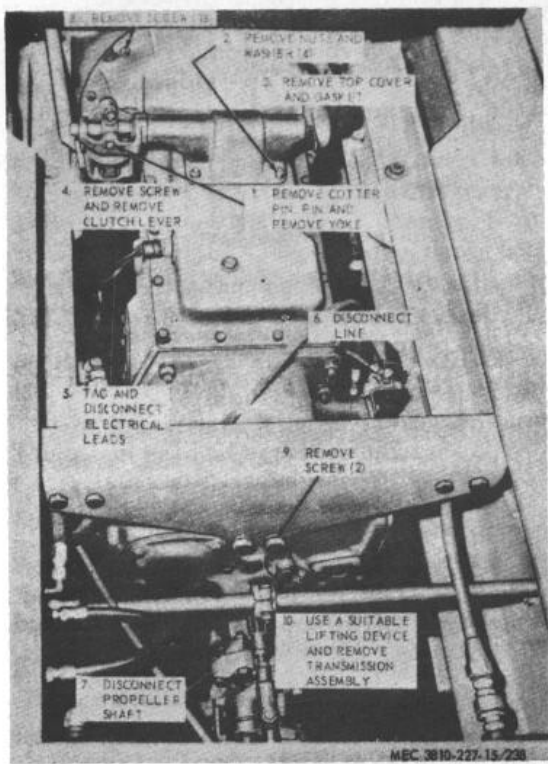

**Figure 238. Carrier engine top cover and transmission assembly, removal and installation.**

- (2) Disassembly of main housing and gear unit.
  - (a) Remove shift bar housing (7B, fig. 239).
  - (b) Shifting by hand, engage transmission into two speeds, at same time. Loosen companion flange nut.
  - (c) Remove housing (45C, fig. 239) by removing nuts (48) and lockwasher (47).

**Note**

**Be careful not to damage shim (41D, fig. 239).**

- (d) Remove mainshaft drop gear cotter pin (27), nut (28), and washer (29).
- (e) Remove mainshaft rear bearing cap retainer screw (32) and lockwire, and bearing cap (35).

**Note**

**Use puller screw to remove bearing and bearing cap.**

- (f) Mainshaft can be removed from case without removing main drive gear.
- (g) Remove main drive gear bearing cap screws, then drive on hub of main drive gear (5) with brass bar and mallet. Bearing cap (1), gasket (2), nut and bearing will come off as an assembly.

1 Cotter pin	7 Control top	13 Lever boot
2 Clevis pin	8 Welch plug	14 Universal lever
3 Anchor bracket	9 Shift finger key	15 Welch plug
4 Locking screw	10 Inside shift finger	16 Draw rod yoke
5 Top snap ring	11 Outside shift finger	17 Yoke swivel bracket
6 Rocker shaft	12 Locking, wire	18 Lever snap ring

**A-Remote control assembly**

1 Shift fork	17 Poppet spring	33 Latch plunger
2 Shift fork spacer	18 Poppet ball	34 Set screw
3 Shift rail	19 Shift fork	35 Shift fork
4 Lock ball	20 Rocker lug	36 Welch plug
5 Lock spring	21 Rocker lug screw	37 Set screw
6 Rail spacer	22 Inter lock ball	38 Inter lock ball
7 Shift bar housing	23 Inter lock ball	39 Inter lock ball
8 Pivot pin nut	24 Inter lock pin	40 Shift rail
9 Pivot Din lockwasher	25 Shift lug	41 Set screw
10 Shift fork bar	26 Latch plunger nut	42 Shift rail spacer
11 Welch plug	27 Inter lock pin	43 Welch plug
12 Neutral switch	28 Inter lock ball	44 Shift lug
13 Neutral switch boot	29 Shift rail	45 Lock ball
14 1st & rev. rocker arm	30 Set screw	46 Poppet spring
16 Shift fork screw	31 Welch plug	
16 Rocker arm pivot pin	32 Latch plunger spring	

**B-Shift bar and housing assembly**

**Figure 239. Carrier engine transmission assembly, exploded view.**

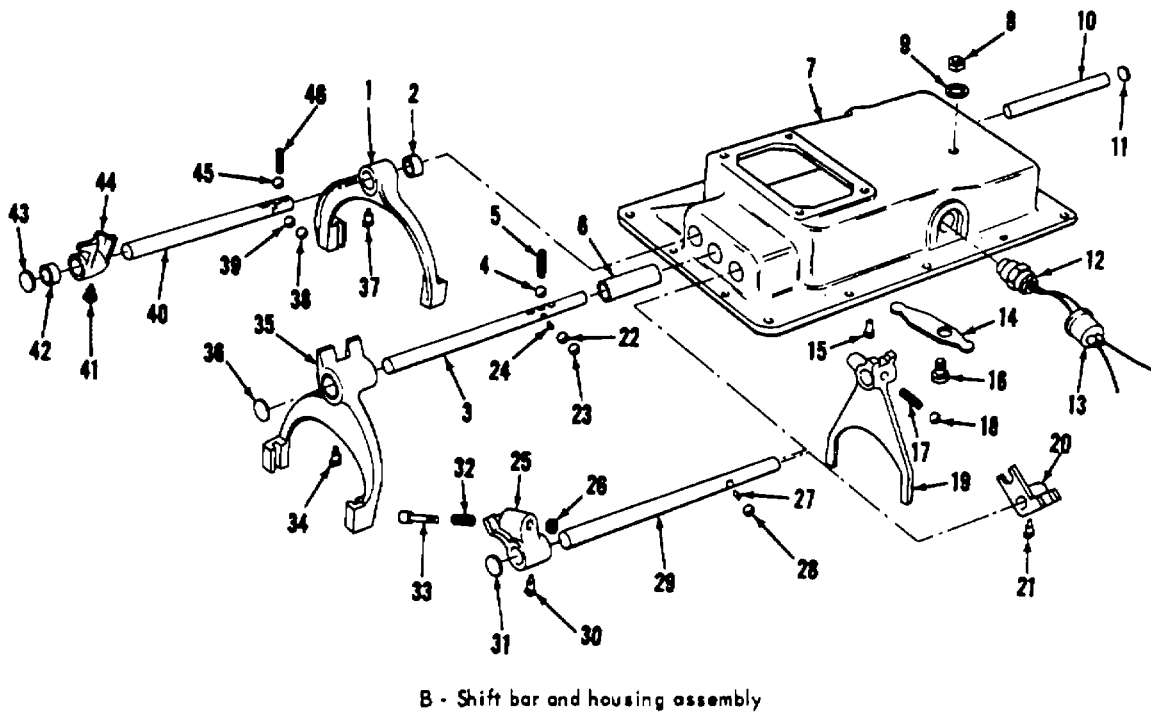
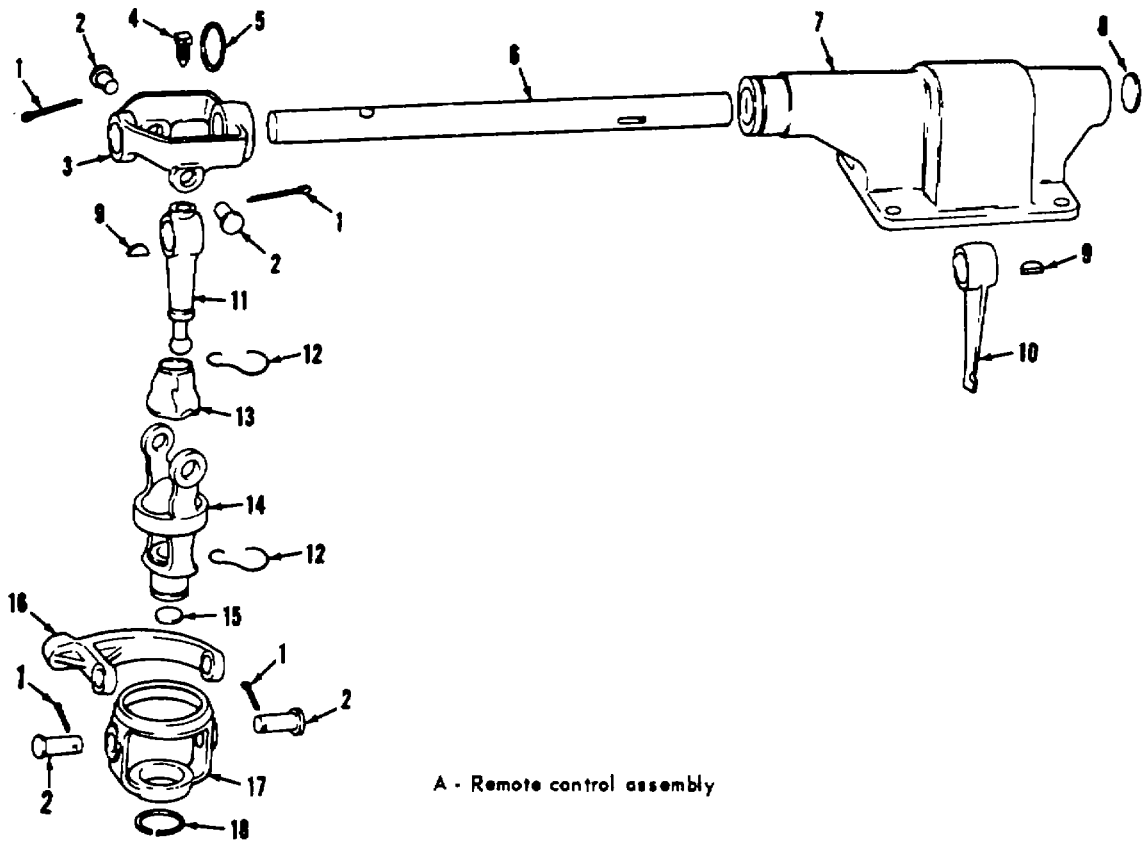

MEC 3810-227-15/239 ①

Figure 239. Continued.

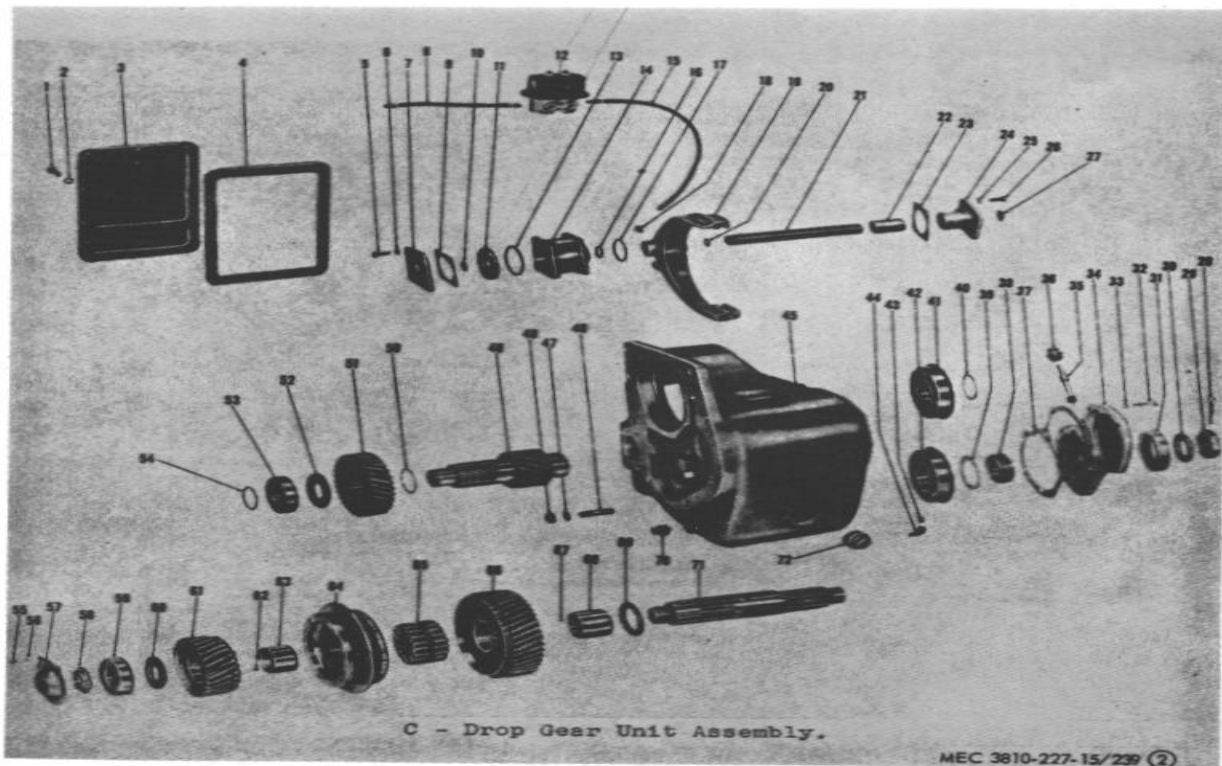

- |                            |                                 |                               |
|----------------------------|---------------------------------|-------------------------------|
| 1 Cover screw              | 26 Lockwasher                   | 49 Intermediate shaft         |
| 2 Lockwasher               | 26 Screw                        | 50 Gear locating ring         |
| 3 Control cover            | 27 Welch plug                   | 51 Gear                       |
| 4 Cover gasket             | 28 Cotter pin                   | 52 Gear spacer                |
| 5 Screw-includes Item 6    | 29 Nut                          | 63 Front bearing              |
| 6 Lockwasher               | 30 Washer                       | 54 Retaining ring             |
| 7 Shift cylinder cover     | 31 Oil seal                     | 55 Screw-includes Item 56     |
| 8 Air line-short           | 32 Cover screw-includes Item 33 | 56 Lockwasher                 |
| 9 "O" ring                 | 33 Lockwasher                   | 57 Oil baffle & tube assembly |
| 10 Retaining ring          | 34 Cover & bushing assembly     | 58 Retaining nut              |
| 11 Air shift piston        | 35 Speedometer driven gear      | 59 Front bearing              |
| 12 Solenoid valve          | 36 Speedometer tube nut         | 60 Thrust washer              |
| 13 Quad ring seal          | 37 Gasket                       | 61 Gear & bushing assembly    |
| 14 Air shift cylinder body | 38 Speedometer drive gear       | 62 Sleeve lock pin            |
| 15 Air line-long           | 39 Not used                     | 63 Bushing, sleeve            |
| 16 "O"ring                 | 40 Retaining ring               | 64 Synchronizer assembly      |
| 17 "O"ring                 | 41 Rear bearing                 | 65 Hub, sleeve                |
| 18 Shift lock screw        | 42 Rear bearing                 | 66 Gear and bushing assembly  |
| 19 Fork & Bushing Assembly | 43 Air breather                 | 67 Sleeve lock pin            |
| 20 "O" ring                | 44 Elbow                        | 68 Bushing, sleeve            |
| 21 Shift rod               | 45 Drop gear housing            | 69 Thrust washer              |
| 22 Spacer                  | 46 Stud                         | 70 Drain plug                 |
| 23 Gasket                  | 47 Lockwasher                   | 71 Output shaft               |
| 24 Adapter                 | 48 Stud nut                     | 72 Filler plug                |

C-Drop gear unit assembly

Figure 239-Continued.

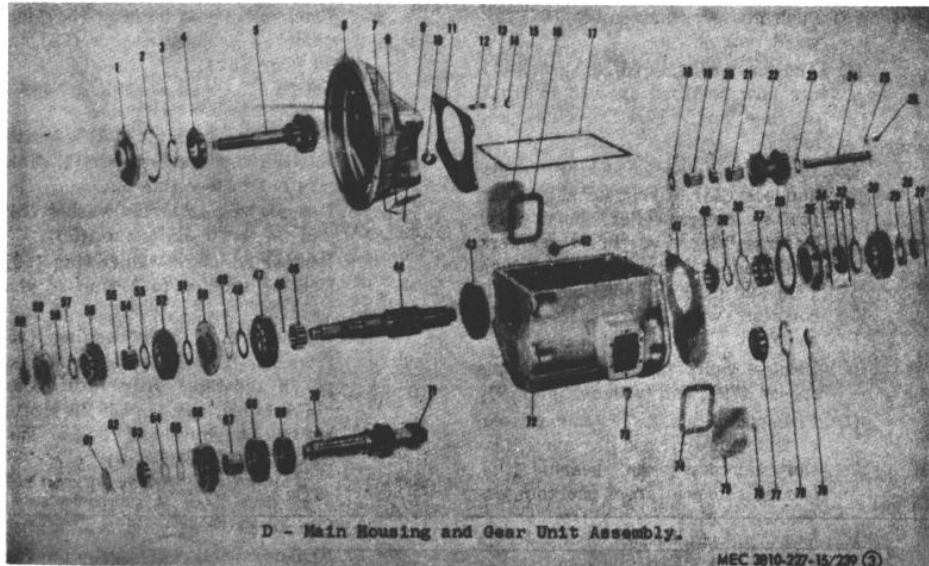

- |    |  |     |                                  |
|----|--|-----|----------------------------------|
| 1  | Bearing cap  | 48  | let & rev. gear                  |
| 2  | Bearing cap gasket                                 | 44  | Mainshaft                        |
| 9  | Retainer nut                                       | 45  | Bushing sleeve                   |
| 4  | Bearing  | 46  | Bushing sleeve pin               |
| 5  | Main drive gear                                    | 47  | Gear & bushing assembly          |
| 6  | Clutch housing & bushing assembly                  | 48  | Gear retainer washer             |
| 7  | Includes Item 10 Lockwasher                        | 48A | Gear retainer washer             |
| 8  | Cover plate  | 48B | Gear retainer washer             |
| 9  | Screw  | 49  | Gear retaining ring              |
| 10 | Bushing  | 50  | Speed synchronizer assembly      |
| 11 | Gasket   | 61  | Thrust washer                    |
| 12 | Studs  | 52  | Gear & bushing assembly          |
| 13 | Lockwashers  | 53  | Gear locating washer             |
| 14 | Nut  | 64  | Gear bushing sleeve              |
| 15 | P.T.O. cover plate                                 | 55  | Gear bushing pin                 |
| 16 | P.T.O. cover gasket                                | 66  | Gear & bushing assembly          |
| 17 | Housing gasket                                     | 57  | Gear retaining washer            |
| 18 | Thrust washer                                      | 57A | Gear retaining washer            |
| 19 | Idler bearing                                      | 57B | Gear retaining washer            |
| 20 | Bearing spacer                                     | 58  | Gear retaining ring              |
| 21 | Bearing  | 59  | Speed synchronizer assembly      |
| 22 | Gear   | 60  | Bearing                          |
| 28 | Thrust washer                                      | 61  | Welch plug                       |
| 24 | Shaft  | 62  | Retaining ring                   |
| 25 | Shaft lock   | 68  | Front bearing                    |
| 26 | Lock screw & lockwasher                            | 64  | Front bearing spacer             |
| 27 | Cotter pin   | 65  | Gear snap ring                   |
| 28 | Gear nut   | 66  | Drive gear                       |
| 29 | Gear washer  | 67  | Gear spacer                      |
| 80 | Drop gear  | 68  | Gear-4th                         |
| 31 | Rear oil seal                                      | 69  | Gear-3rd                         |
| 32 | Capscrew   | 70  | Gear key                         |
| 83 | Mainshaft rear bearing-includes Items 37, 89, & 40 | 71  | Countershaft                     |
| 34 | Bearing washer                                     | 72  | Transmission case & insert assy. |
| 85 | Bearing cap  | 73  | Drain plug                       |
| 86 | Bearing cap gasket                                 | 74  | P.T.O. cover gasket              |
| 37 | M.S. rear bearing-includes Items 38, 89, & 40      | 75  | P.T.O. cover                     |
| 38 | Bearing retaining ring                             | 76  | P.T.O. cover screw lockwasher    |
| 39 | M.S. rear bearing-includes Items 33, 37, & 40      | 77  | Rear bearing                     |
| 40 | M.S. rear bearing-includes Items 38, 87, & 89      | 78  | Bearing spacer                   |
| 41 | Housing shim                                       | 79  | Bearing nut                      |
| 42 | Filler plug  |     |                                  |

D-Main housing and Gear Unit Assembly

Figure 239. Continued.

- (h) Push mainshaft assembly (44) toward rear of case.
- (i) The forward end of mainshaft (44) can now be tilted upward to front of case and entire assembly removed.
- (j) Remove reverse idler lockscrew (26) and lock (25). Using suitable puller remove reverse idler shaft (24). Reverse idler, two thrust washers (18) and (23), two roller bearings (21) and (19) and spacer (20) will come out when idler shaft (24) is removed.
- (k) Remove countershaft rear bearing spacer (78), and bearing nut (79).
- (l) Push countershaft (71) toward rear of transmission case, far enough so that rear countershaft bearing (77) can be removed from the countershaft.
- (m) The countershaft assembly can now be removed by tilting forward end upward, in a manner similar to that used in removing the mainshaft.
- (n) Remove countershaft front bearing (63) by use of offset screw driver or proper bearing puller. Insert end having bit at right angle to handle under bearing and pry lightly around outer race until bearing is worked out of case.

(3) Disassembly of various subassemblies.

(a) Mainshaft assembly.

1. Remove inboard half of inner race of mainshaft rear bearing (40). Use puller on 1st and reverse gear (43).
2. Remove first and reverse sliding gears (43) from shaft.
3. Place balance of assembly in vise using copper or lead jaws so as not to damage splines. Place pilot end of mainshaft (44) upward.
4. Using a suitable puller, remove mainshaft pilot bearing (60).
5. Remove 4th and 6th shift hub (59).
6. Remove 4th gear retainer ring (58) washer (57) and gear (56).
7. Remove 4th gear bushing (54), lock pin (55), locating washer (53) and 3d gear (52).

**Note**

**If bushing slips off without puller it should be replaced.**

**Caution**

**Lock pin (55) is located between bushing and shaft. Take care not to lose this pin.**

8. Remove 3d gear thrust washer (61) and 2d & 3d shift hub (50).
9. Remove 2d gear retainer ring (49), locating washer (48), and 2d gear (47).
10. To remove 2d gear bushing (45) from shaft use brass or bronze punch and tap lightly with mallet.

**Caution**

**Lock pin (46) is located between bushing and shaft. Take care not to lose pin.**

**Note**

**Do not remove 2d gear bushing sleeve unless it is to be replaced.**

(b) Countershaft assembly:

1. Remove spacer (64) and snap ring (66).
2. Press gear (66) from shaft.
3. Remove drive gear key (70), drive gear spacer (67), 4th gear (68) and 3d speed gear (69).
4. Remove remaining gear keys.

(c) Shift bar housing assembly (B, fig. 239).

1. Tag each rail, shift fork, and lug as to it's position in cover so that it may be reassembled properly.
2. To remove neutral switch (12), unscrew from cover.
3. Remove neutral switch actuating ball (28).
4. With shift bar housing upside down and welch plug holes toward repairman, remove welch plugs.
5. Shift all rails into neutral position, then remove all shift forks and shift lug lockwires and lockscrews.
6. Starting on left side of housing, remove 1st & reverse rail (29).

**Note**

**Caution should be used not to lose row over pin (27).**

7. Remove 1st & reverse rocker lug (20) and shift lug (25).

8. Remove 4th and 5th shift rail (3).

**Caution**

**Be sure to hold hand over poppet hole in rail support to prevent loss of poppet balls and spring as rail is removed.**

**Note**

**Caution should be used not to lose cross-over pin (24).**

9. Remove 4th and 5th shift fork (35) and spacer (6).
10. Remove 2d and 3d shift rail (40) using same procedure as was followed in 7 above.
11. Remove 2d and 3d shift fork (1) and lug (44) and spacer (2).
12. Remove two poppet balls (4, 45) and spring (5, 46) as well as four interlock balls (22, 23, 38, 39). (There are six balls and two springs).
13. Remove reverse shift bar (10) from housing by driving on interior end of rail with punch and hammer.

**Note**

**Be sure to hold hand over poppet hole in reverse shift fork (19), to prevent loss of ball (18) and spring (17).**

14. Remove reverse fork (19).
  15. Remove pivot pin (16) and 1st and reverse rocker arm (14).
- (d) Main drive gear and bearing assembly (D, fig. 239).
1. Place gear (5) in vise using copper or lead jaws so as not to damage teeth.
  2. Destake the nut, using a small chisel in the slot. Using suitable wrench, remove jam nut retaining bearing on gear.
  3. Using suitable puller, or arbor press, remove bearing (4) from gear.
- (e) Case and bell housing assembly (D, fig. 239). Remove retaining stud nut (14) and lockwashers (13) and separate above mentioned parts.

**Note**

**It is recommended that this be done only in the event replacement of either part is required.**

- (f) Mainshaft rear bearing cap assembly (D, fig. 239).
1. Remove bearing retainer snap ring (38) from bearing cap (35).
  2. Place bearing cap (35) in arbor press, resting on -flange of bearing cap.
  3. Using driver resting on inner race of bearing, press out of bearing cap (35).
  4. Drive out oil seal (31) using a punch. (If removed, it must be replaced.) (4) Disassembly of drop gear unit (C, fig. 239).
    - (a) Remove high control cover screws (1) and lockwashers (2).
    - (b) Remove high low control cover (3) and gasket (4).
    - (c) Remove high low shift fork lockwire and lockscrew (18).
    - (d) Remove shift rod adapter screws (26) and lockwasher (25).
    - (e) To remove shift rod adapter (24) tap lightly on adapter from inside housing.
    - (f) Remove all shift cylinder housing mounting bolts.
    - (g) Remove air shift cylinder body (14).
    - (h) Remove high low shift fork (19) and over shift spacer (22).
    - (i) Remove output shaft oil baffle screws (55) and lockwashers and remove baffle (57).
    - (j) Remove output shaft front bearing retainer nut (58).
    - (k) Hold onto flange with a pipe wrench. Remove companion flange nut and washer flange.
    - (l) Remove rear bearing cover screws (32) and lockwashers (33).
    - (m) Remove rear bearing cover (34) and gasket (37).
    - (n) Remove speedometer drive gear (38).
    - (o) Using brass or bronze bar drive the output shaft (71) through rear bore. The low gear bushing (68), lockpin (67), thrust washer (69),

and bearing (42) will remain on shaft.

- (p) The high gear thrust washer (60), high gear (61), high gear bushing (63), lockpin (62), high low synchronizer (64), hub (65) and low gear (66), may be removed from the housing as a unit.

**Note**

**Use caution not to lose lockpin (62).**

- (q) To finish disassembling output shaft (71) use suitable puller to remove bearing (42) or place in arbor press with threaded end up and remove bearing. Then remove thrust washer (69), bushing (68), and lockpin (67). To remove bushing, block under thrust washer (69), and press off the opposite end of bearing (42).

**Note**

**Use caution not to lose lockpin.**

- (r) To remove output shaft-front bearing (69) press out through bore of case.
- (s) To remove intermediate shaft (49) first remove rear bearing retainer ring (40).
- (t) Drive on front of intermediate shaft (49) with brass or bronze bar until back bearing comes completely out of bore in case. Using a suitable puller, remove bearing (41).

(5) Disassembly of drop gear unit subassemblies (C, fig. 239).

- (a) Cover and bushing assembly (84).

1. Remove speedometer driven gear nut (86) from bearing cap.
2. Gear (35) may now be removed from cap.
3. Press or drive out oil seal assembly (31). This should be done only if oil seal is to be replaced.

- (b) Intermediate shaft (49).

1. Remove front bearing locating ring (54).
2. Place in arbor press or use suitable puller and remove gear (51) spacer (62) and bearing (58).
3. Remove intermediate shaft gear locating ring (50).

- (c) Air shift cylinder body (14).

1. Remove cylinder cover screws (5).
2. Press on end of rod (21) with hand to remove piston.
3. To remove piston (11) from rod (21), remove retaining ring (10).
4. Quad seal (13) and O-ring (17, 20, & 16) may now be removed.

**472. Carrier Transmission Assembly Cleaning, Inspection, and Repair**

a. *Cleaning.* Clean all parts with an approved cleaning solvent and dry thoroughly.

b. *Inspection and Repair.* Inspect all parts for excessive wear and damage. Replace or repair all damage or defective parts.

**473. Carrier Transmission Assembly Reassembly and Installation**

- a. *Reassembly.*

- (1) Reassembly of various subassemblies.

- (a) Mainshaft (D, fig. 289).

1. Clamp mainshaft (44) into vise using copper or lead jaw shields, with pilot end up.
2. Using suitable driver, put 2d gear bushing (45) on shaft.

**Note**

**Bushing should drive on with lockpin (46) toward top of shaft.**

3. Place 2d gear (47) on shaft, with toothed hub of gear up.
4. Place 2d gear retainer washer (48) on shaft.

**Note**

**If gear has been replaced, select proper retainer washer (one of three) to get proper end play .008 .013 inches.**

5. Place new retainer ring (49) on shaft.
6. When placing 2d and 3d shift hub (50) on shaft, note one side of synchronizer hub is under cut for 2d gear retainer ring. Place this side down.
7. Place 3d gear thrust washer (51) on shaft.
8. Put 8d gear (62) on shaft, with toothed hub of gear down.
9. Place 4th gear locating washer (53) on shaft.

- Using suitable driver put 4th gear bushing (64) on shaft.

**Note**

**Bushing (54) should drive on with lockpin (65) toward top of shaft.**

- Place 4th gear (56) on shaft with toothed hub of gear up.
- Place 4th gear retainer washer (57) on shaft.

**Note. If gear has been replaced, select proper retainer washer (one of three) to get proper end play ON0 to .013 inch.**

- Place 4th gear retainer ring (58) on shaft.
- Place 4th and 5th shift hub (69) on shaft.

**Note**

**One side of shift hub is under cut for 4th gear retainer ring, place this side down.**

- Press pilot bearing (60) on shaft.
- Install 1st and reverse sliding gear (43) on shaft with fork slot away from threaded end.
- Press front half of roller bearing on mainshaft.

**Note**

**Press on inner race.**

(b) Countershaft assembly.

- Install rear woodruff key (70) into slot in countershaft.
- Press countershaft 3d gear (69) onto shaft.
- Install next woodruff key and press countershaft 4th gear (68) onto shaft.

**Note**

**The longer hub on gear should be up.**

- Place countershaft drive gear spacer (67) on shaft.
- Install remaining woodruff key and press countershaft drive gear (66) on shaft.

**Note**

**The long hub on the gear should be down.**

- Install countershaft drive gear retainer (65) on end of shaft.

(c) Main drive gear and bearing assembly.

- Assemble bearing (4) on main drive gear (6) with snap ring toward pilot end of gear.

- Assemble jam nut (3) drawing up tight.

- Stake nut into position.

(d) Case and bell housing assembly (D, fig. 239).

- Assemble bell housing retaining studs (12) into clutch housing.
- Install drive gear (5) and drive gear bearing assembly into case (72).
- Install drive gear bearing cap (1) over drive gear and secure with bolts and lockwashers.
- Place bell housing in position on case and assemble lockwashers and nuts. Tighten securely.

(e) Shift bar housing reassembly (B, fig. 239).

- Install rocker arm pivot pin (16). Install pin through from inside cover. Install flat washer, lockwasher (9) and nut (8).
- Place shift bar housing (7) on bench in an upside down position with welch plug holes facing repairman.
- Place 1st and reverse rocker arm (14) over pivot pin with long end to the right.
- Using suitable tool, compress spring (17) with ball (18) in position in reverse fork (19) poppet hole.
- Place reverse fork in position, with poppet hole pointed toward left side of cover.
- Push bar (10) through opening in far end of cover and through fork.
- Tap on end of bar until setscrew hole in cover and hole in shaft is lined up.
- Place setscrew (15) in place and tighten securely.
- Slide 2d-3d shift rail (40) through opening on right.
- Place spacer (42) on rail.
- Place 2d-3d shift lug (44) on rail, with set screw opening and shift slot toward center of cover.
- Place 2d-3d shift fork (1) and spacer (2) on rail, with set screw opening toward repairman.
- Place poppet spring (46) and ball (45) in poppet hole in cover.



14. Using suitable tool, compress spring with ball in position and slide rail through rail support.
15. Place lockscrew (41) in shift lug and lockscrew (37) in shift fork.
16. Shift into neutral position.
17. Slide 1st-reverse shift rail (29) through opening on left.
18. Place 1st-reverse shift lug (25) on rail with set screw opening up, and shift slot toward center of cover.
19. Place interlock pin (27) in hole in shift rail with pin in rail, in a horizontal position; push rail through rail support.
20. Place 1st-reverse rocker lug (20) on end of rail with lockscrew hole up and in position on rocker arm (14).
21. Put lockscrews (30, 21) in place and tighten.
22. Shift rail into neutral position.
28. Slide 4th-5th shift rail (3) through opening in center.
24. Place 4th-5th shift fork (35) and spacer (6) on rail with setscrew hole in fork away from repairman.
25. Place two interlock balls (22, 23, 38, 39) in cross holes in rail support on both sides of remaining opening.
26. Place poppet spring (6) and ball (4) in poppet hole in cover.
27. Using suitable tool, compress spring with ball in position.
28. Place interlock pin (24) in hole in shift rail, with pin in rail, in a horizontal position, push rail through.
29. Place setscrew (34) in position and tighten.
30. Shift rail into neutral position.
31. Install lockwires into all screws. This should be done in such manner as not to interfere with shifting.
32. Check assembly of cover by shifting in and out of all speeds. Then shift center rail into 4th speed and attempt to shift side rails into speeds at same time. This provides a check on proper assembly of interlock plugs, balls and pin.

**Caution**

**Cover should NOT shift into more than one speed at a time.**

33. If assembly functions properly, install welch plugs into place.

**Note**

**Make sure welch plugs are aluminum.**

34. Turn cover over.
35. Check actuating pin (24) to see if it is in place, install actuating ball (28) and neutral switch (12).
  - (f) Reassembly of mainshaft rear bearing cap assembly (D, fig. 239).
    1. Press cup bearing (37) into bearing cap (35). Bearing cap should be resting on rear of cap.
    2. Snap in a new snap ring (38).
  - (2) Reassembly of drop gear unit subassembly (C, fig. 239).
    - (a) Cover and bushing assembly (34).
      1. If oil seal has been removed, press in oil seal (31).
      2. Place speedometer driven gear (86) in position.
      3. Install speedometer driven gear nut (36).
    - (b) Intermediate shaft (49).
      1. Install intermediate shaft gear locating ring (50).
      2. Press gear (51) on shaft with long hub toward the retainer ring.
      3. Put spacer (52) on shaft, with oil grooves toward gear.
      4. Press bearing (53) on end of shaft, until bearing shoulders against spacer (52).
      5. Install bearing retainer ring (54) on shaft (49).
    - (c) Air shift cylinder body (14).
      1. Install new 0-ring (20) on shift rod (21).
      2. Install piston (11) on rod (21), then place retainer ring (10) in place.
      3. Install new 0-ring (16) in body (14).
      4. Insert rod (21) and piston (11) into body (14).
      5. Replace 0-ring (9) and cover (7) on housing.

6. Replace cover screws (5).
  7. Install new O-ring (17) on body (14).
- (3) Reassembly of drop gear unit (C, fig. 239).
- (a) Install intermediate shaft (49) through control cover opening on side of housing. Put shaft through rear bearing opening with front bearing lined up with bore. Drive shaft into place.
  - (b) Supporting front end of intermediate shaft (49) in some manner, drive rear bearing (41) into place using suitable drive, drive on inner race of bearing.
  - (c) Install intermediate shaft rear bearing retainer ring (40).
  - (d) Press output shaft rear bearing (42) on output shaft (71) over threaded end until bearing is flush with shoulder on shaft.
  - (e) Place thrust washer (69) on shaft (71) with oil groove away from bearing.
  - (f) Using suitable driver press bushing (68) on shaft with lockpin (67) away from thrust washer.
  - (g) Place output shaft low gear (66) on bench with toothed hub up.

**Note**

**Check blocker pins on synchronizer to see if they show maximum staggering when synchronizer is examined standing on edge.**

- (h) Place synchronizer hub (65) in synchronizer (64). Put synchronizer on gear with grooved ring in gear (66).
- (i) Place output shaft high gear (61) on top of synchronizer with side with internal teeth down.
- (j) Turn synchronizer (64) and gears (61) and (66) on side and roll into drop gear housing with gear (66) to the rear case.
- (k) Lay housing over on front so it is resting on the studs (46).
- (l) Center up splines in synchronizer hub and gears so splines on shaft (71) can be installed in position.

Rotate shaft until splines are lined up. Install shaft and rear bearing (42) into hole using proper driver.

- (mn) Put speedometer drive gear (38) on rear of output shaft.
- (n) Install output shaft rear bearing cap gasket (37) and cover and bushing assembly (34) with screws (32) and lockwashers (33).

**Note**

**Use permatex or sealing lead on threads of screws.**

- (o) Return assembly to horizontal position.
- (p) Insert bushing (68) and lockpin (67), with lockpin toward front of case. Line oil hole in bearing sleeve with hole in shaft.

**Caution: Use extreme care when putting bushing (68) in, so as not to damage bushing in gear (61).**

- (q) Place thrust washer (60) on shaft with oil grooves facing the gear.
- (r) Install output shaft front bearing (59).
- (s) Install companion flange, flange washer (30) and nut (29). Put into two gears at once and tighten nut.

**Note**

**Recommended torque for this nut is 500 to 600 ft. lb.**

- (t) Tighten output shaft front bearing retainer nut (58).

**Note**

**Companion flange nut must be tightened before output shaft front bearing retainer nut.**

- (u) Place cotter key in shaft to secure nut in place.
- (v) Install front bearing retainer nut.
- (w) Install output shaft oil baffle (57), with screws (55) and lockwashers.
- (x) Install high-low shift fork (19) with long hub of fork toward front of case.
- (y) Install air shift cylinder with screws and lockwashers. Insert shaft through fork.

**Note**

**Use permatex or sealing lead on threads of screws.**

- (z) Place spacer (22) on cylinder shaft.

**Note**

**Be sure holes in shaft and fork line up.  
Install setscrew into fork and tighten  
lockwire.**

- (aa) Place shift rod adapter gasket (23) and adapter (24) over shaft and insert in housing, with oil drain hole in adapter down. Use screws (26) and lockwashers.

**Note**

**Use permatex or sealing lead on  
threads of screws.**

- (bb) Place control cover gasket (4) and control cover (3) on housing. Use screws (1) and lockwashers (2) to secure in place.
- (4) Reassembly of transmission (D, fig. 239).
- (a) Install countershaft front bearing (63). Be sure to apply pressure on outer race of bearing only.
  - (b) Place countershaft front bearing spacer (64) in position on forward end of countershaft (71).
  - (c) Tip rear end of countershaft down and lower into case, running rear of countershaft through countershaft bearing opening in rear of case far enough so that front of countershaft may be lowered into position.
  - (d) Install countershaft rear bearing (77). Be sure that snap ring is in position in groove of the outer race of countershaft rear bearing and press this bearing into position on shaft with snap ring toward rear.
  - (e) Insert two roller bearings (19) and (21) separated by spacer (20) into hub of reverse idler gear (22) and lower into position in case. The gear with chamfered teeth should be toward rear of case.
  - (f) Insert reverse idler shaft (24) through hole in rear of case. Place two thrust washers (18) and (23) one at each end, with copper face toward the gear. Line up locating notches, then put shaft through reverse gear (22) and into forward support boss. Shaft should be 268 driven in until forward face of slot in shaft is flush with rear

face of case and slot lined up to permit installation of shaft lock (25).

- (g) Install shaft lock (25) in position in slot in end of shaft and secure with capscrew (26) and lockwasher.
- (h) Install mainshaft assembly (44) in transmission case by tilting rear end of assembly down and lowering into and through opening in rear of case which is provided for mainshaft rear bearing, lower front end in line with pilot bearing opening and move mainshaft assembly forward into position.
- (i) Install main drive gear and bearing assembly (5) into opening in front of case so that main drive gear engages and meshes with countershaft gear.
- (j) Install main drive gear bearing cap (1) and gasket (2).

**Caution**

**Be sure oil return hole in cap is lined  
up with oil return hole in case. This  
passage must be open and clean.**

- (k) Install main drive bearing capscrews and lockwasher.
- (l) Install countershaft rear bearing spacer (78).
- (m) Install countershaft rear bearing retainer nut (79), and tighten.
- (n) Assemble inboard half of mainshaft rear bearing (40) over end of mainshaft. Use suitable driver.

**Note**

**Permatex shim on both sides.**

- (o) Place drop gear housing shim (41), D, figure 239, on studs, on case.
- (p) Assemble mainshaft rear bearing cap (35) on case (72) using capscrews (32) and lockwashers (34).
- (q) Remainder of re-assembly is done after mainshaft has been reassembled into case.
  1. Drive rear bearing cap (35) into mainshaft (44) until it is flush against case.

2. Slip bearing spacer (39) on end of mainshaft.
3. Put capscrews (32) into rear bearing cap (35).
4. Drive mainshaft rear bearing outer cone (33) on mainshaft (44) into bearing cap (35).
5. Drive in new oil seal (31).

**Note**

**Spring loaded lip of seal toward bearing.**

- (r) Place the drop gear (30) on the mainshaft (44), then washer (29), nut and cotter.
- (s) Place housing (C, fig. 239) on back of transmission.
- (t) Install nuts (48) and lockwashers (47) and tighten.
- (u) With transmission and control cover, shifted into neutral, install gasket and cover on transmission.

**Note**

**Two short bolts go in back two corner holes of cover.**

- (v) Install cover screws and lockwasher. Tighten securely.
- (w) Install drain plugs.

**Caution: Must be brass.**

- (5) Reassembly of remote control assembly (A, fig. 239).
  - (a) Clamp control top (7) upside down in vise.
  - (b) If pivot anchor bracket was removed it should be reinstalled first

and held in place by retainer ring (6)

- (c) Place shift finger (11) with boot (13) in place in the universal lever (14).
- (d) Hold shift finger and universal lever assembly in place. Slide rocker shaft (6) through bracket and shift finger.
- (e) Install clevis pins (2) in pivot bracket (3).
- (f) While holding inside shift finger in place slide the shaft into place.
- (g) Install woodruff keys (9) in rocker shaft, slide shift finger over woodruff key and secure the shift fingers with lock screws (4) and safety wire.
- (h) Place safety wires (12) on boot (13).
- (i) Assemble draw rod yoke (16) on place over yoke swivel bracket (17) and install clevis pins (2).
- (j) Assemble yoke assemble over universal lever (14) and secure with retainer ring (18).

*b. Installation.*

- (1) Install the carrier engine clutch housing as instructed on figure 226.
- (2) Install the carrier transmission assembly as illustrated on figure 238.
- (3) Connect the propeller shaft (para. 244).
- (4) Fill the transmission case assembly

## Section XLVII. CARRIER TRANSFER CASE ASSEMBLY

### 474. General

The carrier transfer case assembly is located to the rear of the transmission and provides a high and low speed range for the rear and front axle. It provides a means of disengaging the front axle entirely. Two levers located to the right of the operator's seat control the transfer case. The speedometer drive and the emergency hand brake are integral parts of the transfer case.

### 475. Carrier Transfer Case Assembly Removal and Disassembly

*a. Removal.*

- (1) Drain the transfer case assembly.
- (2) Disconnect the speedometer drive assembly from the transfer case.
- (3) Disconnect the handbrake cable from the brake.
- (4) Remove the three propeller shafts

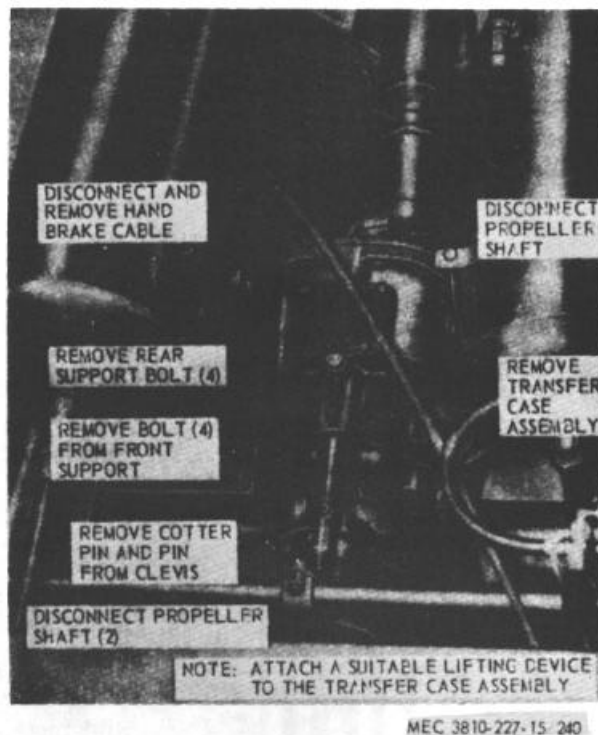

**Figure 240. Carrier transfer case assembly, removal and installation.**

from the three universal yokes on the transfer case (para. 244).

- (5) Remove the transfer case assembly as instructed on figure 240.

*b. Disassembly.* Disassemble the carrier transfer case assembly in the order of numerical sequence as illustrated on figure 241.

#### **476. Carrier Transfer Case Assembly, Cleaning, Inspection, and Repair**

##### *a. Cleaning.*

- (1) Clean all parts with an approved cleaning solvent. Dry thoroughly.

**Note**

**Do not spin a dry bearing with compressed air.**

- (2) Use an approved cleaning solvent to clean all threads. Remove dirt, sludge, and caked grease from shaft splines and gear teeth.

- (3) Remove all dirt, sludge, and grease from the transfer case and bearing cap recesses.

##### *b. Inspection and Repair.*

- (1) Inspect the transfer case, cover bearing caps, bellcranks, levers, brake drum, and yokes for cracks, breaks, distortion or other damage. Repair or replace defective parts as necessary.
- (2) Inspect all gears for chipped or broken teeth, excessive wear, broken splines, or other damage. Replace all defective gears.
- (3) Inspect the bearings for wear, scoring, and binding. Inspect the bearings for free rotation. Replace all defective bearings.
- (4) Inspect all shims for cracked or torn edges. Replace all defective shims.
- (5) Inspect all shafts for distortion, broken, or chipped splines, scoring, pitting, burrs, stripped threads, or other damage. Repair or replace defective shafts as necessary.

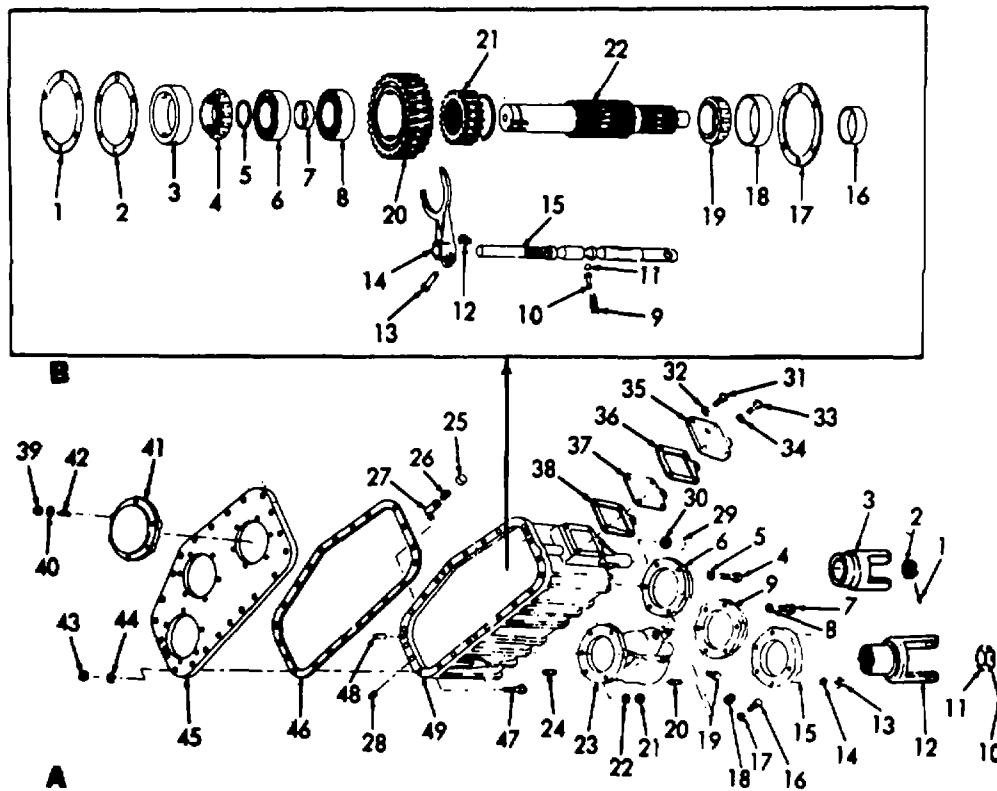

MEC 3810-227-15/241 ①

- |                     |                        |                     |
|---------------------|------------------------|---------------------|
| 1 Pin, cotter       | 18 Plug, pipe          | 35 Gear shift cover |
| 2 Nut, castellated  | 19 Screw, cap          | 36 Gasket           |
| 3 Shaft yoke        | 20 Stud                | 37 Breather plate   |
| 4 Screw, cap        | 21 Nut                 | 38 Gasket           |
| 5 Washer, lock      | 22 Washer, lock        | 39 Nut              |
| 6 Bearing cover     | 23 Carrier bearing     | 40 Washer, lock     |
| 7 Screw, cap        | 24 Stud                | 41 Bearing cover    |
| 8 Washer, lock      | 25 Pipe cap            | 42 Stud             |
| 9 Bearing cover     | 26 Nipple, pipe        | 43 Nut              |
| 10 Pin, cotter      | 27 Elbow, street       | 44 Washer, lock     |
| 11 Nut, castellated | 28 Plug, pipe          | 45 Cover            |
| 12 Universal yoke   | 29 Packing retainer    | 46 Gasket           |
| 13 Nut              | 30 Gear shaft, packing | 47 Screw, cap       |
| 14 Washer, lock     | 31 Screw, cap          | 48 Taper pin        |
| 15 Carrier cap      | 32 Washer, lock        | 49 Transfer case    |
| 16 Screw, cap       | 33 Screw, cap          |                     |
| 17 Washer, lock, IT | 34 Washer, lock        |                     |

A—Transfer case and cover

- |                  |                    |                 |
|------------------|--------------------|-----------------|
| 1 Gasket         | 9 Spring           | 17 Gasket       |
| 2 Shim           | 10 Lock plunger    | 18 Bearing cup  |
| 3 Bearing cup    | 11 Lock ball       | 19 Bearing cone |
| 4 Bearing cone   | 12 Nut             | 20 Drive gear   |
| 5 Bearing spacer | 13 Screw, cap      | 21 Sliding gear |
| 6 Ball bearing   | 14 Gearshift fork  | 22 Input shaft  |
| 7 Gear spacer    | 15 Gearshift shaft |                 |
| 8 Ball bearing   | 16 Oil seal        |                 |

B—Input shaft and gear

Figure 241. Carrier transfer case assembly, exploded view.

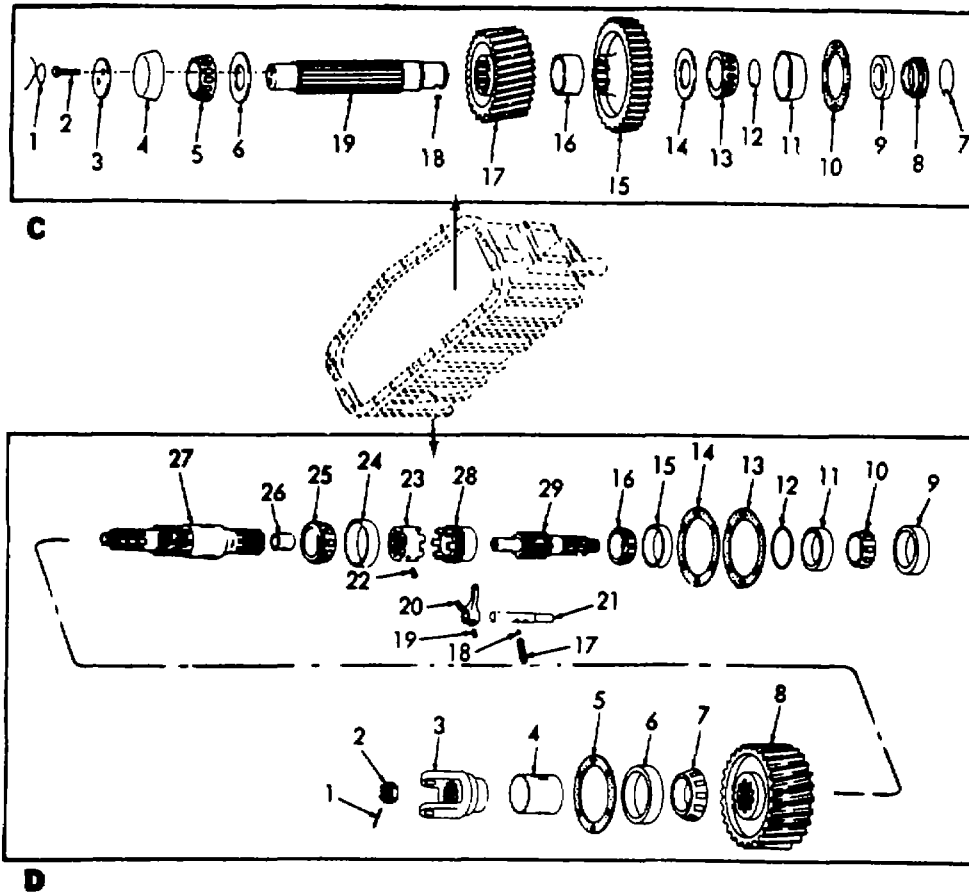

MEC 3810-227-15/241 (2)

- |                      |                          |                   |
|----------------------|--------------------------|-------------------|
| 1 Lockwire           | 8 Speedometer drive gear | 15 Low speed gear |
| 2 Screw, cap         | 9 Drive gear spacer      | 16 Gear spacer    |
| 3 Bearing lockwasher | 10 Cover gasket          | 17 Idler gear     |
| 4 Bearing cup        | 11 Bearing               | 18 Woodruff key   |
| 5 Bearing cone       | 12 Retainer ring         | 19 Idler shaft    |
| 6 Bearing spacer     | 13 Bearing cone          |                   |
| 7 Retainer ring      | 14 Bearing spacer        |                   |

C—Idler shaft and gear

- |                         |                 |                   |
|-------------------------|-----------------|-------------------|
| 1 Pin, cotter           | 11 Bearing cup  | 21 Shift shaft    |
| 2 Nut, castellated      | 12 Bearing shim | 22 Lock screw     |
| 3 Brake mounting flange | 13 Gasket       | 23 Driving clutch |
| 4 Flange spacer         | 14 Gasket       | 24 Bearing cup    |
| 5 Gasket                | 15 Bearing cup  | 25 Bearing cone   |
| 6 Bearing Cup           | 16 Bearing cone | 26 Pilot bushing  |
| 7 Bearing cone          | 17 Spring       | 27 Output shaft   |
| 8 Driven gear           | 18 Lock ball    | 28 Sliding clutch |
| 9 Oil seal              | 19 Fork screw   | 29 Declutch shaft |
| 10 Bearing cone         | 20 Shaft fork   |                   |

D—Declutch shaft, output shaft, and driven gear

Figure 241. Continued.

- (6) Inspect all threaded parts for stripped or damaged threads. Repair or replace parts as necessary.
- (7) Inspect all metal mating surfaces for burrs. Remove all burrs.
- (8) Inspect the bearing cups for excessive wear, scoring, pitting, or other damage. Replace a defective cup and cone as a set.
- (9) Inspect the spacers, washers, and retaining rings for cracks, breaks, twisting, excessive wear, or other damage.  
Replace defective parts as necessary.
- (10) Inspect the brakeshoe lining for wear, breaks, or cracks. Replace defective lining.
- (11) Inspect the mounting brackets and the yokes for cracks, breaks, distortion, or other damage. Repair or replace damaged parts as necessary.
- (12) Inspect the two shifting yokes and shafts for distortion, wear, breaks, or other damage. Repair or replace defective parts.
- (13) Inspect the spring balls and plungers for distortion, wear, pitting, or other damage. Replace all defective parts as necessary.
- (14) Always use new gaskets, oil seals, and shims during reassembly.

**477. Carrier Transfer Case Assembly Reassembly and Installation**

*a. Reassembly.* Reassemble the transfer case in the reverse of the numerical sequence as instructed on figure 241.

*b. Installation.*

- (1) Install the carrier transfer case assembly as illustrated on figure 240.
- (2) Install the three propeller shafts on the three universal yokes on the transfer case (para. 244).
- (3) Reconnect the handbrake cable on the brake.
- (4) Reconnect the speedometer drive assembly on the transfer case.
- (5) Fill the transfer case assembly.
- (6) Adjust the control levers.

**Section XLVIII. CARRIER AIR COMPRESSOR ASSEMBLY**

**478. General**

The carrier air compressor assembly is a single acting, reciprocating two cylinder type. The rated capacity is 71/4 cubic feet per minute at 1,250 rpm. The minimum oil pressure required at engine idling speed is 5 pounds per square inch and at minimum governed speed is 15 pounds per square inch. The compressor runs continuously while the engine is running, but the actual compression of air is controlled by the governor, which, acting in conjunction with the unloading mechanism in the compressor cylinder block, starts the compression of air by loading the compressor when the pressure in the air brake system reaches the desired minimum 80-86 pounds. The compressor is lubricated by oil from the engine crankcase and is air-cooled.

**479. Carrier Air Compressor Assembly Removal and Disassembly**

*a. Removal.* Remove the carrier air compressor assembly as instructed on figure 242.

*b. Disassembly.* Disassemble the carrier air compressor assembly in numerical sequence as illustrated on figure 243.

**480. Carrier Air Compressor Assembly Cleaning, Inspection, and Repair**

*a. Cleaning.* Clean all parts with an approved cleaning solvent and dry thoroughly.

*b. Inspection and Repair.*

- (1) Inspect all parts for excessive wear and damage.
- (2) Plug all holes in the cylinder head except one and insert air hose. Immerse cylinder head in water and apply 15



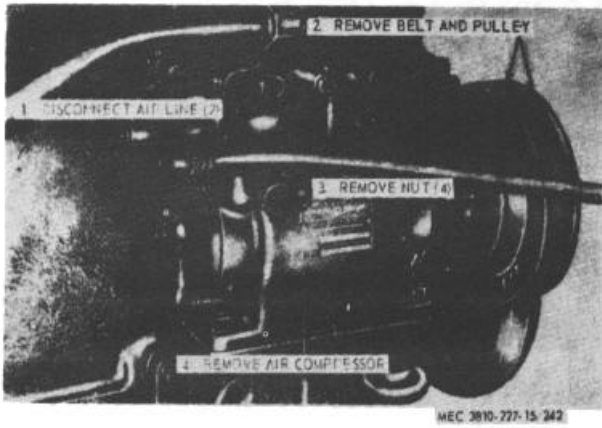

**Figure 242. Carrier air compressor assembly, removal and installation.**

psi air pressure. Watch for signs of air bubbles. Remove cylinder head from water and disconnect air hose.

- (3) Inspect the inlet valves and seats. If inlet valves are grooved deeper than 0.003 inch where they contact the seat, they are defective.
- (4) Inspect the cylinder bores. If they are scored or out of-round more than 0.002 inch, or tapered more than 0.003 inch, the cylinder block is defective.  
Clearance between pistons and cylinder bores should be between 0.002 and 0.004 inch.
- (5) Inspect the fit of the piston ring gap and the fit in the piston grooves. The gap clearance is 0.007 to 0.019 inch and the groove clearance is 0.0016 to 0.0030 inch.
- (6) Inspect the clearance of wrist pin. The wrist pin to the connecting rod bush

1	Strainer cap	12	Seal ring	23	Valve body
2	Seal ring	13	Spring	24	Exhaust stem spring
3	Neoprene washer	14	Inlet valve spring	25	Exhaust stem
4	Filter	15	Inlet exhaust valve	26	Pin, cotter
5	Valve body cap	16	Packing	27	Nut
6	Seal ring	17	Inlet valve seat	28	Diaphragm follower
7	Pin, cotter	18	Shim, 0.10 in.	29	Diaphragm
8	Nut	19	Shim, 0.003 in.	30	Diaphragm follower
9	Spring seat	20	Guide bushing	31	Diaphragm stem
10	Spring	21	Packing	32	Packing
11	Valve body cap	22	Screw, machine	33	Spring cage
A-Compressor governor assembly					
1	Nut	5	Gasket	9	Valve seat
2	Washer, lock	6	Discharge valve cap nut	10	Screw, cap
3	Stud	7	Valve spring	11	Cylinder head
4	Discharge fitting	8	Discharge valve	12	Head gasket
B-Compressor cylinder head					
1	Plug, pipe	12	Unloader piston	23	Connecting rod cap
2	Plug, pipe	13	Back up ring	24	Bearing insert
3	Unloader seat	14	Packing	25	Piston
4	Unloader spring	15	Bushing	26	Piston rings
5	Unloader saddle	16	Screw, cap	27	Piston rings
6	Inlet valve spring	17	Washer, lock	28	Lockwire
7	Inlet valve guide	18	Cylinder block body	29	Wrist pin
8	Inlet valve	19	Block gasket	30	Connecting rod
9	Inlet valve seat	20	Pin, cotter	31	Wrist pin bushing
10	Plunger guide	21	Nut		
11	Unloader plunger	22	Connecting rod bolt		
C-Connecting rod, piston, and cylinder block					
1	Plug, pipe	7	Cover gasket	13	Cover gasket
2	Plug, pipe	8	Ball bearing	14	Ball bearing
3	Screw, cap	9	Oil seal	15	Woodruff key
4	Washer, lock	10	Screw, cap	16	Crankshaft
5	Rear end cover	11	Washer, lock	17	Gasket
6	Seal ring	12	End cover	18	Crankcase
D-Crankshaft and crankcase body					

**Figure 243. Carrier air compressor assembly, exploded view.**

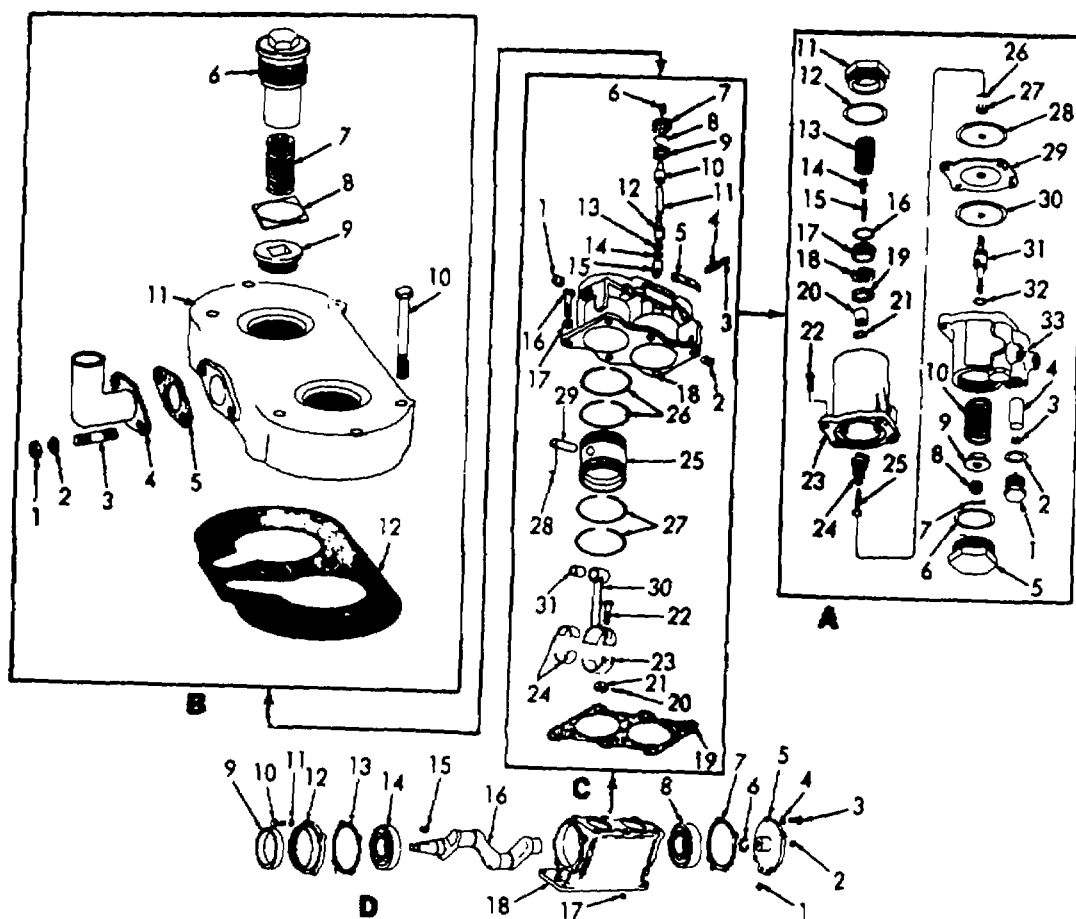

MEC 3810-227-15/243

Figure 243. Continued.

- ing clearance should not exceed 0.0015 inch.
- (7) Clearance between the connecting rod journal and the connecting rod bearings must be less than 0.003 inch or more than 0.021 inch after rebuilding compressor rising insert type rods.
- (8) Inspect the crankshaft 4ournals, if they are more than 0.002 inch out-of round or scored, the crankshaft and bearings are defective.
- (9) After installing new discharge valves, springs, and capnuts, the discharge valve travel should be between 0.036 and 0.058 inch.
- (10) Test discharge valve for leakage by applying 100 psi air pressure through the discharge port of the cylinder head and apply soap suds to the valve openings in the cylinder head floor. Leakage should not exceed a one inch soap bubble in not less than 5 seconds. Test discharge valve capnuts by this method.
- (11) The dimensions from the top of the cylinder block to the inlet valve seat should not exceed 0.145 inch. After installing new seats, the dimension should be 0.101 to 0.113 inch.
- (12) Replace or repair all damaged or defective parts.

#### 481. Carrier Air Compressor Assembly Reassembly and Installation

a. *Reassembly.* Reassemble the carrier air compressor assembly in the reverse of the numerical sequence as illustrated on figure 248.

b. *Installation.* Install the carrier air compressor assembly as illustrated on figure 242.

### Section XLIX. CARRIER FRONT AIR BRAKE CHAMBER ASSEMBLY

#### 482. General

The carrier's two front air brake chamber assemblies each consist basically of two circular housings or plates, a push rod assembly, and a diaphragm. The purpose of the brake chambers is to convert the energy of the compressed air into mechanical force and motion necessary to operate the front brakes. When the air pressure is released from the brake chamber, a spring returns the diaphragm and push rod assembly to the released position.

#### 483. Carrier Front Air Brake Chamber Assembly Removal and Disassembly

a. *Removal.* Remove the carrier front air brake chamber assembly (para. 234).

b. *Disassembly.* Disassemble the carrier front air brake chamber assembly in numerical sequence as illustrated on figure 244.

#### 484. Carrier Front Air Brake Chamber Assembly, Cleaning, Inspection and Repair

a. *Cleaning.* Clean all parts with an approved cleaning solvent and dry thoroughly.

b. *Inspection and Repair.* Inspect all parts for excessive wear or damage. Replace or repair all defective parts.

#### 485. Carrier Front Air Brake Chamber Assembly, Reassembly and Installation

a. *Reassembly.* Reassemble the carrier front air brake chamber assembly in the reverse of the numerical sequence as illustrated on figure 244.

b. *Installation.* Install the carrier front air brake chamber assembly (para. 284).

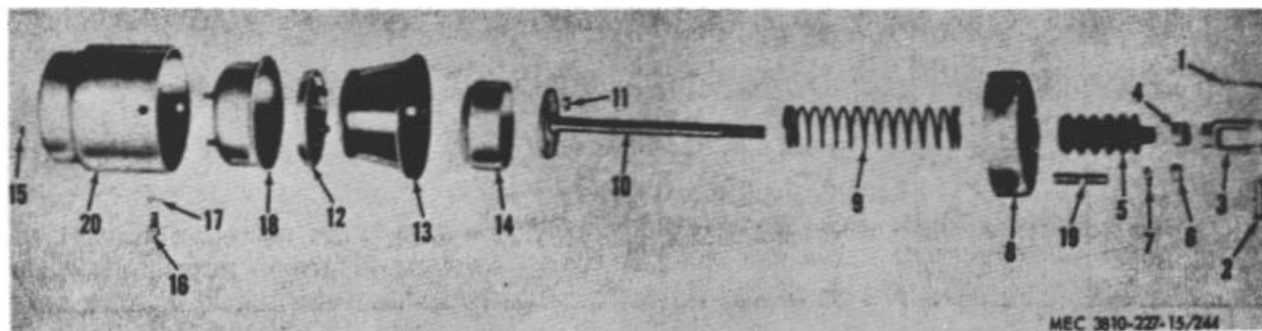

1 Cotter pin	8 Cover	15 Hex nut
2 Yoke pin	9 Spring	16 Cap screw
3 Yoke	10 Push rod	17 Lockwasher
4 Hex nut	11 Lockwasher	18 Outer clamp
5 Boot	12 Inner clamp	19 Stud
6 Hex nut	13 Diaphragm	20 Body
7 Lockwasher	14 Diaphragm guide	

Figure 244. Carrier front air brake chamber assembly, exploded view.

### Section L. CARRIER REAR AIR BRAKE CHAMBER ASSEMBLY

#### 486. General

The carrier's four rear air brake chamber assemblies each consist basically of two circular housings called plates, a

push rod assembly, and a diaphragm. The purpose of the brake chambers is to convert the energy of com-

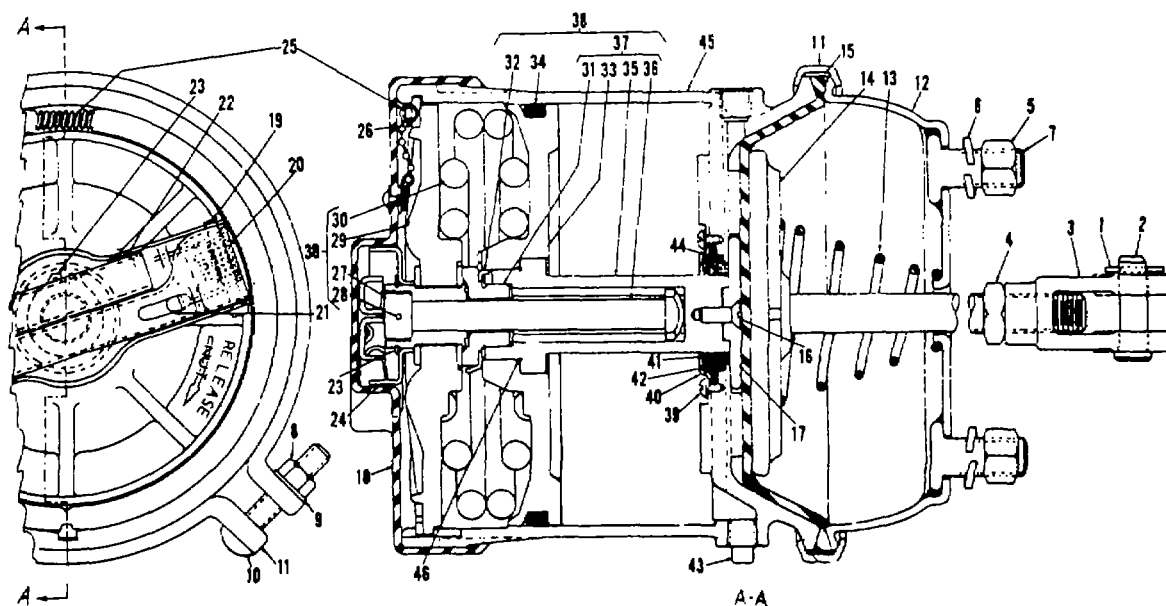

MEC 3810-227-15/245

1 Cotter pin	13 Spring	25 Lock spring	37 Piston sub assembly
2 Clevis pin	14 Push rod	26 Retaining ring, right and left	38 Piston cover assembly
3 Yoke	15 Diaphragm	27 Nut	39 Screw
4 Jam nut	16 Screw	28 Pin	40 Cap
5 Nut	17 Plunger	29 Cover plate	41 O-ring
6 Lockwasher	18 Boot	30 Spring	42 Bushing
7 Bolt	19 Rivets	31 Piston nut	43 Pipe plug
8 Nut	20 Spring	32 Washer	44 Static O-ring
9 Washer	21 Handle w/stop	33 Piston	45 Cylinder housing
10 Bolt	22 Handle wo/stop	34 O-ring	46 O-ring
11 Clamp band	23 Snap ring	35 Piston shaft	
12 Housing	24 Cross bar	36 Bolt	

Figure 245. Carrier rear air brake chamber assembly, exploded view.

pressed air to mechanical force and motion necessary to operate the rear brakes. When the air pressure is released from the brake chamber, a spring returns the diaphragm and push rod assembly to the released position.

#### 487. Carrier Rear Air Brake Chamber Assembly Removal and Disassembly

*a. Removal.* Remove the carrier rear air brake chamber assembly (para. 234).

*b. Disassembly.* Disassemble the carrier rear air brake chamber assembly in numerical sequence as illustrated on figure 245.

#### 488. Carrier Rear Air Brake Chamber Assembly Cleaning, Inspection, and Repair

*a. Cleaning.* Clean all parts with an approved cleaning solvent, and dry thoroughly.

*b. Inspection and Repair.* Inspect all parts for excessive wear or damage. Replace or repair all defective parts.

#### 489. Carrier Rear Air Brake Chamber Assembly Reassembly and Installation

*a. Reassembly.* Reassemble the carrier rear air brake chamber assembly in the reverse of the numerical sequence as illustrated on figure 245.

*b. Installation.* Install the carrier rear air brake chamber assembly (para. 234).

## Section LI. CARRIER MOISTURE EJECTOR VALVE ASSEMBLY

### 490. General

The carrier moisture ejector valve assembly is a small relay valve with no delivery ports. A line from the bottom of the dry tank to the inlet port of the ejector carries a combination of air, moisture, and sludge into the area in the body between the seat, that the movable seat seals against, and the O-ring. With each brake application, air enters the ejector through the application line port. This application air forces the actuator down and pushes the valve away from its seat on the casting, allowing about a spoonful of moisture to be admitted to the area under the O-ring. Upon release of the brake application, the actuator is forced up, allowing the seat to seal off any further flow of moisture or air from the tank and opening the exhaust port through the center of the seat. This permits moisture to flow out.

### 491. Carrier Moisture Ejector Valve Assembly Removal and Disassembly

a. *Removal.* Remove the carrier moisture ejector valve assembly (para. 237).

b. *Disassembly.* Disassemble the carrier moisture ejector valve assembly in numerical sequence as illustrated on figure 246.

### 492. Carrier Moisture Ejector Valve Assembly Cleaning, Inspection and Repair

a. *Cleaning.* Clean all parts with an approved cleaning solvent and dry thoroughly.

b. *Inspection and Repair.* Inspect all parts for excessive wear and damage. Replace all defective parts.

### 493. Carrier Moisture Ejector Valve Assembly, Reassembly and Installation

a. *Reassembly.* Reassemble the carrier moisture ejector valve assembly in the reverse of

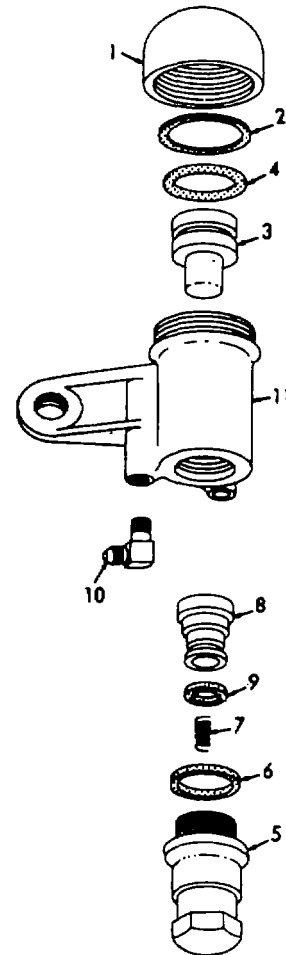

MEC 3810-227-15/246

1	Cap	7	Spring
2	Gasket	8	Valve seat
3	Actuator	9	O-ring
4	O-ring	10	Elbow
5	Lower body	11	Body
6	Gasket		

Figure 246. Carrier moisture ejector valve assembly, exploded view.

the numerical sequence as illustrated on figure 246.

b. *Installation.* Install the carrier moisture ejector valve assembly (para. 237).

## Section LII. CARRIER AIR BRAKE DOUBLE CHECK VALVE ASSEMBLY

### 494. General

The carrier's double check valves are used in an air brake system when it is necessary to automatically direct the flow of air pressure into a common line from either of two other lines. Both of the carrier air brake double check valves are used in conjunction with two brake control valves. If the double check valves were not used and either of the brake control valves were moved to the applied position, tank pressure would escape through the exhaust port of the other brake control valve.

### 495. Carrier Air Brake Double Check Valve Assembly Removal and Disassembly

a. *Removal.* Remove the carrier air brake double check valve assemblies (para. 232).

b. *Disassembly.* Disassemble the carrier air brake double check valve assembly in numerical sequence as illustrated on figure 247.

### 496. Carrier Air Brake Double Check Valve Assembly Cleaning, Inspection, and Repair

a. *Cleaning.* Clean all parts with an approved cleaning solvent and dry thoroughly.

b. *Inspection and Repair.* Inspect all parts for excessive wear and damage. Replace or repair all defective parts.

### 497. Carrier Air Brake Double Check Valve Assembly Reassembly and Installation

a. *Reassembly.* Reassemble the carrier air brake double check valve assembly in the reverse of the numerical sequence as illustrated on figure 247.

b. *Installation.* Install the carrier air brake double check valve assembly (para. 232).

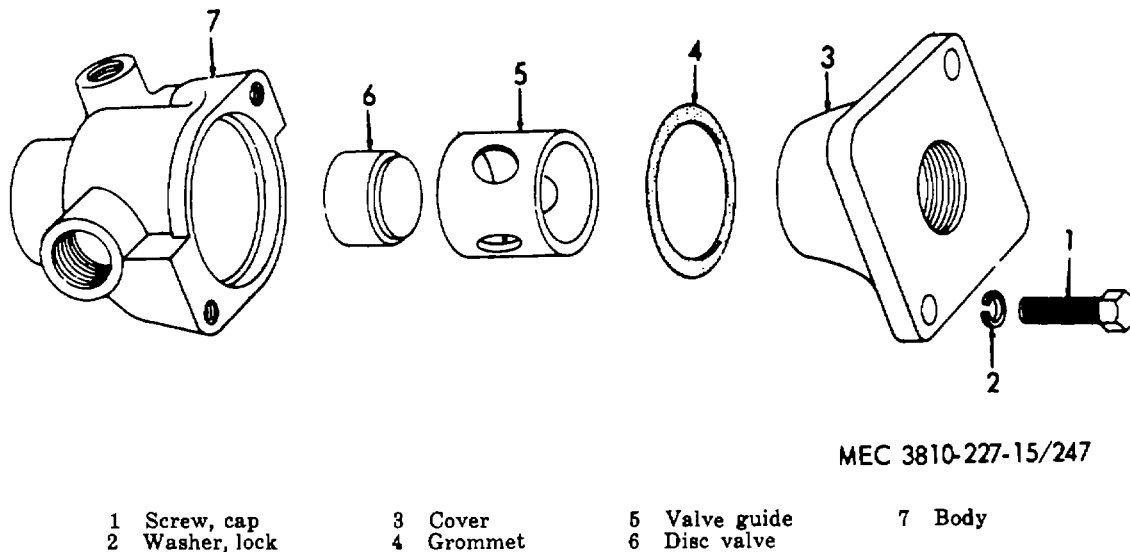

Figure 247. Carrier brake (disc type) double check valve assembly, exploded view.

## Section LIII. CARRIER HANDBRAKE

### 498. General

The carrier handbrake is a mechanically operated brake lever. It works through a series of devices and rods.

### 499. Carrier Handbrake Removal and Disassembly

a. *Removal.* Remove the carrier handbrake as instructed on figure 248.

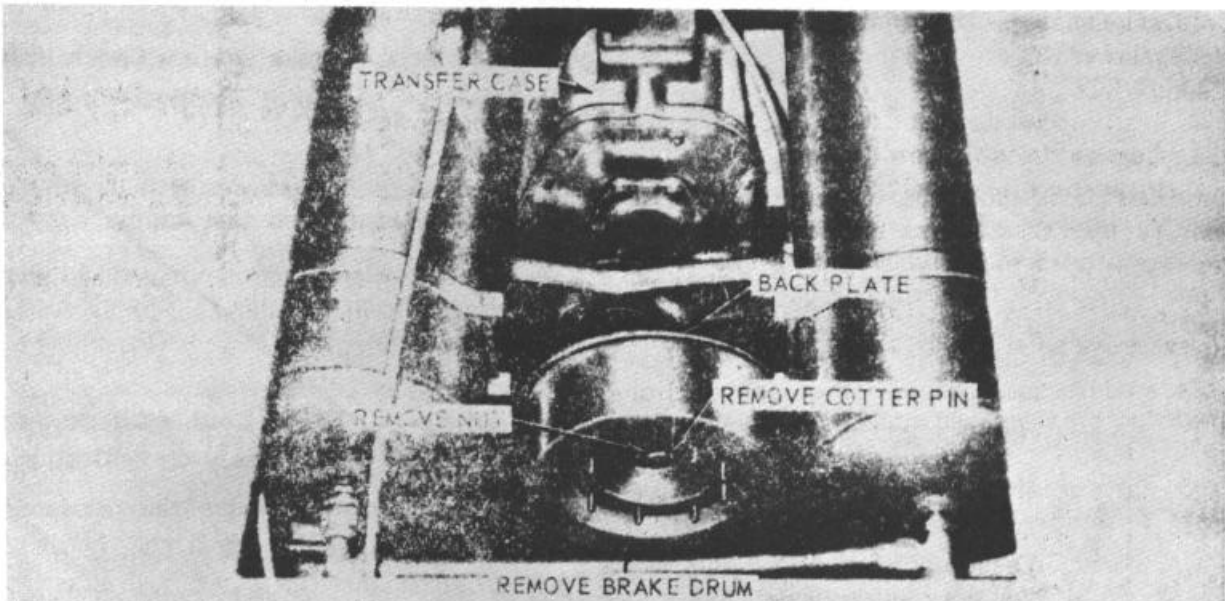

A-Carrier Handbrake, Brakedrum, Installed.

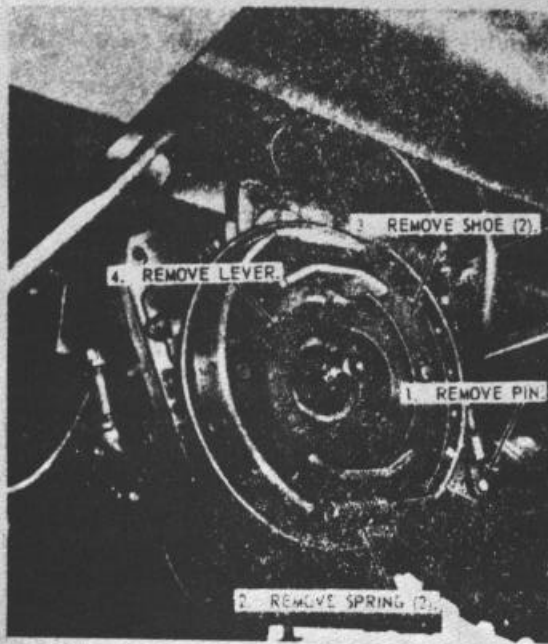

B-Carrier Handbrake, Brake shoe Assembly, Installed.

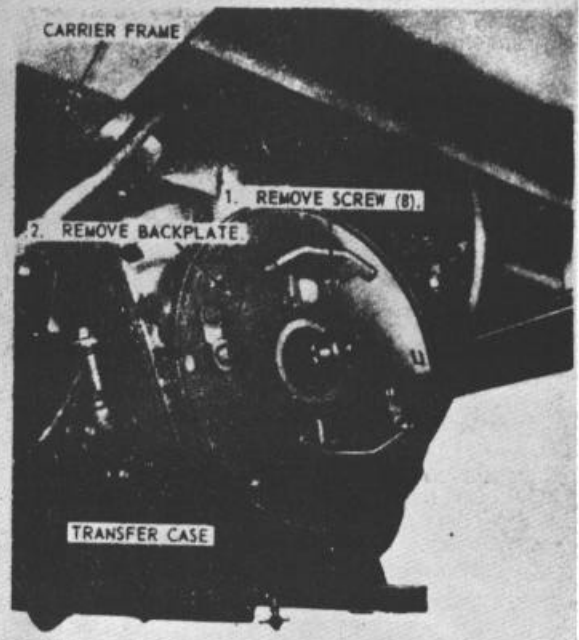

C-Carrier Handbrake, Backplate Assembly, Installed.

MEC 3810-227-15/248

Fig. 248. Carrier handbrake, removal and installation.

b. *Disassembly.* Disassemble the carrier handbrake in numerical sequence as illustrated on figure 249.

### 500. Carrier Handbrake Cleaning, Inspection, and Repair

a. *Cleaning.* Clean all parts with an approved cleaning solvent and dry thoroughly.

b. *Inspection and Repair.* Inspect all parts for excessive wear and damage. Inspect brakedrum for scoring. Replace or repair all defective parts.

### 501. Carrier Handbrake Reassembly and Installation

a. *Reassembly.* Reassemble the carrier handbrake in reverse of the numerical sequence as illustrated on figure 249.

b. *Installation.* Install the carrier handbrake as illustrated on figure 248.

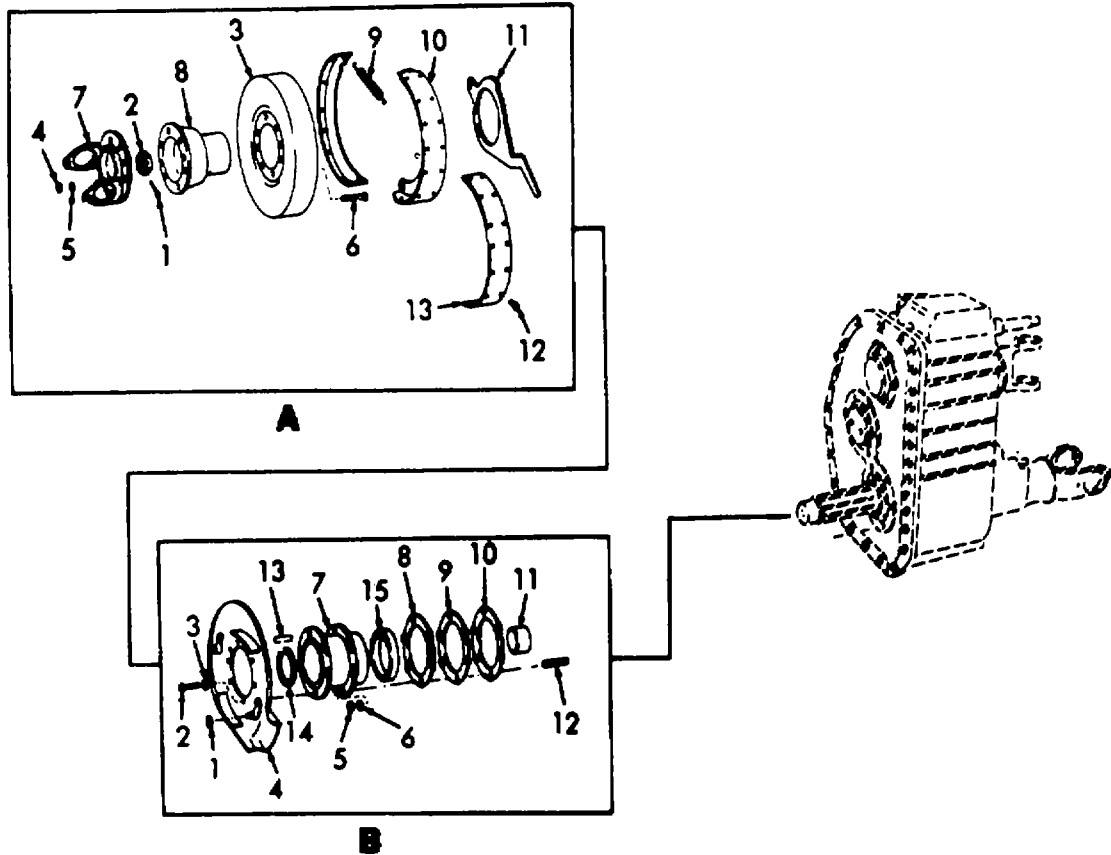

MEC 3810-227-15/249

1 Pin, cotter	4 Nut	7 Flange, yoke	10 Brake shoe assembly	13 Brake lining
2 Nut, special	5 Washer, lock	8 Mounting flange	11 Cam operating lever	
3 Brakedrum	6 Screw, cap	9 Spring	12 Rivet	

A—Brake shoe assembly

1 Roller	6 Washer, lock	11 Spacer
2 Screw, cap	7 Bearing cage	12 Stud
3 Washer, lock	8 Shim	13 Dowel pin
4 Backplate assembly, w/pawl	9 Shim	14 Oil seal
5 Nut	10 Shim	15 Bearing cup

B—Backplate assembly

Figure 249. Carrier emergency handbrake assembly, exploded view.



## Section LIV. CARRIER FRONT SERVICE BRAKE ASSEMBLY

### 502. General

The carrier is equipped with brakes controlled by the air brake system. The mechanical portion of the brake system includes the shoes, liners, drums, and cams. The brakes are applied or released by depressing or releasing the brake pedal. The air pressure causes the brake chamber push rods to move the slack adjusters which rotate the brake cam, forcing the brakeshoes against the brakedrums, causing brake action. When the pressure in the brake chambers is exhausted, the force of the brake chamber springs and the brakeshoe springs pull the push rods, slack adjusters, and brake shoes to their normal positions, releasing the brakes.

### 503. Carrier Front Service Brake Assembly Removal and Disassembly

*a. Removal.* Remove the carrier front service brakeshoe assembly (para. 241).

*b. Disassembly.* Disassemble the carrier front service brakeshoe assembly in numerical sequence as illustrated on figure 250.

### 504. Carrier Front Service Brake Assembly Cleaning, Inspection and Repair

*a. Cleaning.* Clean all parts with an approved cleaning solvent and dry thoroughly.

*b. Inspection and Repair.* Inspect an parts for excessive wear and damage. Replace or repair all defective parts.

### 505. Carrier Front Service Brake Assembly Reassembly and Installation

*a. Reassembly.* Reassemble the carrier front service brakeshoes assembly in the reverse of the numerical sequence as illustrated on figure 260.

*b. Installation.* Install the carrier front service brakeshoe assembly (para. 241).

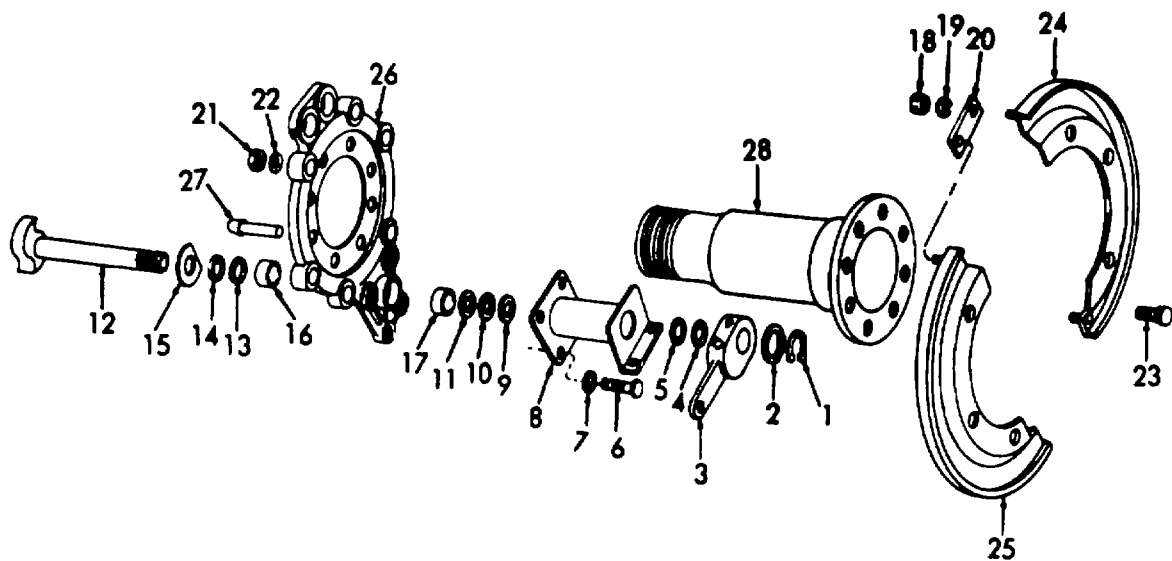

MEC 3810-227-15/250

1 Retaining ring	8 Bracket	15 Camshaft washer	22 Washer, lock
2 Retaining washer	9 Spacer	16 Bushing	23 Screw, cap
3 Slack adjuster	10 Retainer	17 Bushing	24 Dust shield, upper
4 Spacer, thin	11 Felt oil seal	18 Nut	25 Dust shield, lower
5 Spacer, thick	12 Camshaft	19 Washer, lock	26 Spider assembly
6 Screw, cap	13 Felt oil seal	20 Connector plate	27 Rivet
7 Washer, flat	14 Retainer	21 Nut	28 Spindle

Figure 250. Carrier front service brake shoe assembly, exploded view.

## Section LV. CARRIER REAR SERVICE BRAKE ASSEMBLY

### 506. General

The carrier rear service brake assembly is a two shoe, automotive-type, air-actuated brake. The friction set up between the relative motion of the brakeshoe linings and the brakedrum retards the motion of the wheels on the carrier axle.

### 507. Carrier Rear Service Brake Assembly Removal and Disassembly

*a. Removal.* Remove the carrier rear service brakeshoe (para. 242).

*b. Disassembly.* Disassemble the carrier rear service brake assembly in numerical sequence as illustrated on figure 251.

### 508. Carrier Rear Service Brake Assembly Cleaning, Inspection, and Repair

*a. Cleaning.* Clean all parts with an approved cleaning solvent and dry thoroughly.

*b. Inspection and Repair.* Inspect all parts for excessive wear and damage. Replace and repair all defective parts.

### 509. Carrier Rear Service Brake Assembly Reassembly and Installation

*a. Reassembly.* Reassemble the carrier rear service brake assembly in the reverse of the numerical sequence as illustrated on figure 251.

*b. Installation.* Install the carrier rear service brakeshoe, (para. 242).

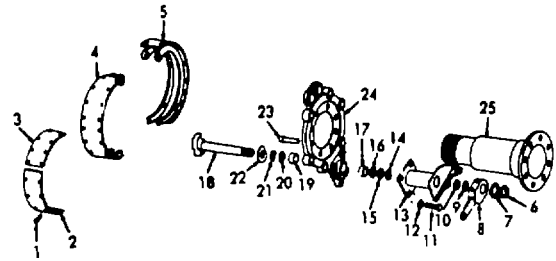

1 Rivet	14 Spacer
2 Lining, anchor end	15 Retainer
3 Lining, cam end	16 Seal
4 Upper brakeshoe	17 Bushing
5 Lower brakeshoe	18 Camshaft
6 Retaining ring	19 Bushing
7 Retaining washer	20 Seal
8 Slack adjuster	21 Retainer
9 Spacer, thin	22 Washer
10 Spacer, thick	23 Rivet
11 Screw, cap	24 Spider
12 Washer, flat	25 Spindle
13 Bracket	

Figure 251. Carrier rear service brakeshoe assembly, exploded view.

## Section LVI. CARRIER TREADLE VALVE ASSEMBLY

### 510. General

The treadle brake valve is fitted with a treadle which is a part of the brake valve. Movement of the treadle operates an inlet and exhaust valve within the treadle brake valve which controls the air pressure delivered to the brake actuators. To fully apply the brakes, the treadle or brake pedal must be fully depressed. When the treadle or brake pedal is only partially depressed, correspondingly less braking force is developed.

### 511. Carrier Treadle Valve Assembly Removal and Disassembly

*a. Removal.* Remove the carrier treadle valve assembly.

*b. Disassembly.* Disassemble the carrier treadle valve assembly in numerical sequence as illustrated on figure 252.

### 512. Carrier Treadle Valve Assembly Cleaning, Inspection, and Repair

*a. Cleaning.* Clean all parts with an approved cleaning solvent and dry thoroughly.

*b. Inspection and Repair.* Inspect all parts for excessive wear and damage. Replace or repair all defective parts.

### 513. Carrier Treadle Valve Assembly Reassembly and Installation

*a. Reassembly.* Reassemble the carrier

treadle valve assembly in the reverse. of the numerical sequence a illustrated on figure 252.

b. Installation. Install the carrier treadle valve assembly.

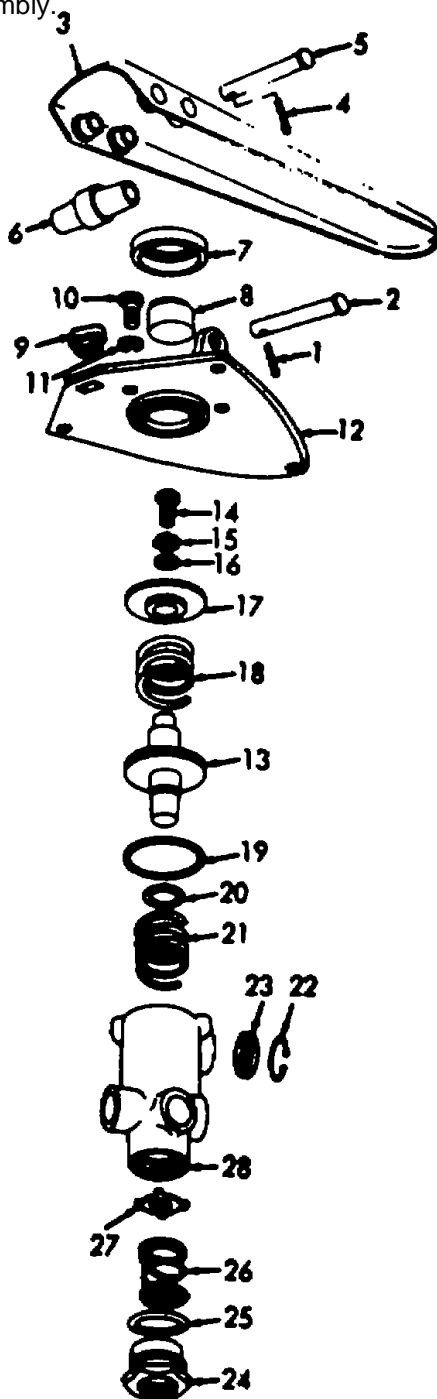

MEC 3810-227-15/252

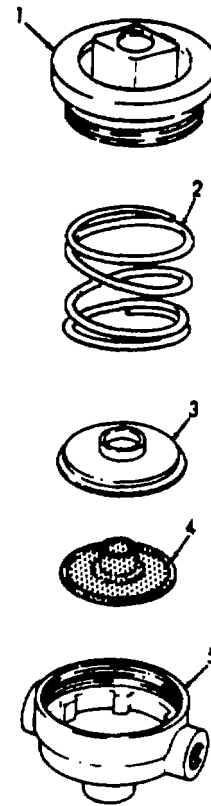

MEC 3810-227-15/253

- |          |             |
|----------|-------------|
| 1 Cover  | 4 Diaphragm |
| 2 Spring | 5 Body      |
| 3 Seat   |             |

Figure 953. Carrier air brake quick release valve assembly, exploded view.

- 
- |                   |                     |
|-------------------|---------------------|
| 1 Pin, cotter     | 15 Washer, lock, ET |
| 2 Pin             | 16 Washer, flat     |
| 3 Treadle body    | 17 Spring seat      |
| 4 Pin, cotter     | 18 Spring           |
| 5 Pin             | 19 Packing          |
| 6 Roller          | 20 Packing          |
| 7 Boot            | 21 Spring           |
| 8 Plunger         | 22 Retaining ring   |
| 9 Stop button     | 23 Filter screen    |
| 10 Screw, cap     | 24 Inlet nut        |
| 11 Washer, lock   | 25 Packing          |
| 12 Mounting plate | 26 Spring           |
| 13 Piston         | 27 Inlet valve      |
| 14 Screw, cap     | 28 Body             |

Figure 252. Carrier brake valve assembly, exploded view.

## Section LVII. CARRIER AIR BRAKE QUICK RELEASE VALVE

### 514. General

The purpose of the carrier quick release valve assembly is to reduce the time required to release the brakes by hastening the exhaust of air pressure from the brake chambers. The valve consists of a body containing a spring loaded diaphragm so arranged as to permit air pressure to flow through the valve in one direction, but when the supply pressure is reduced, the air which has passed through the valve is permitted to escape through the exhaust port.

### 515. Carrier Air Brake Quick Release Valve Removal and Disassembly

a. *Removal.* Remove the carrier air brake quick release valve (para. 235).

b. *Disassembly.* Disassemble the carrier air brake quick release valve in numerical sequence as illustrated on figure 253.

### 516. Carrier Air Brake Quick Release Valve Cleaning, Inspection, and Repair.

a. *Cleaning.*

- (1) Clean all metal parts in an approved cleaning solvent; dry thoroughly.

- (2) Inspect the lower face of the diaphragm which contacts the exhaust port seat in the cover for pits and grooves. Replace a defective diaphragm as necessary.

b. *Inspection and Repair.*

- (1) Inspect the diaphragm for cracks, breaks, punctures, and wear.
- (2) Inspect the lower face of the diaphragm which contacts the exhaust port seat in the cover for pits and grooves. Replace a defective diaphragm as necessary.
- (3) Inspect the body for cracks, breaks, stripped, or damaged threads, and other damage. Replace a defective body.
- (4) Inspect the spring and spring seat for cracks, breaks, bends, and other damage.

### 517. Carrier Air Brake Quick Release Valve Reassembly and Installation

a. *Reassembly.* Reassemble the carrier air brake quick release valve in the reverse of the numerical sequence as illustrated on figure 253.

b. *Installation.* Install the carrier air brake quick release valve (para. 235).

## Section LVIII. CARRIER TRAILER BRAKE VALVE

### 518. General

The carrier trailer brake valve is a Bendix Westinghouse type TC brake valve. It consists essentially of a piston which divides the interior of the valve into two separate chambers. The chamber above the piston is always open to the atmospheric pressure, while the lower chamber may or may not be subject to air system pressure. The position of the piston is determined by the position of the operating handle. The nonrigid connection between the piston and handle, through a spring, automatically maintains a selected pressure to the trailer brakes.

### 519. Carrier Trailer Brake Valve Removal and Disassembly

a. *Removal.* Remove the carrier trailer brake valve from the crane carrier.

b. *Disassembly.* Disassemble the carrier trailer brake valve in the numerical sequence as instructed on figure 254.

### 520. Carrier Trailer Brake Valve Cleaning, Inspection, and Repair

a. *Cleaning.*

- (1) Clean all metal parts with an approved cleaning solvent.

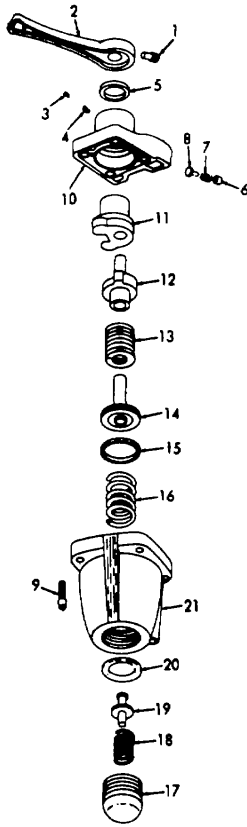

MEC 3810-227-15/254

- |                         |                             |
|-------------------------|-----------------------------|
| 1 Setscrew              | 12 Cam                      |
| 2 Handle                | 13 Spring                   |
| 3 Setscrew              | 14 Piston                   |
| 4 Screw, lock           | 15 Packing, preformed       |
| 5 Adjusting ring nut    | 16 Spring                   |
| 6 Setscrew, socket head | 17 Nut                      |
| 7 Spring                | 18 Spring                   |
| 8 Plunger               | 19 Valve, inlet and exhaust |
| 9 Screw, machine        | 20 Packing, preformed       |
| 10 Cover                | 21 Body                     |
| 11 Cam follower         |                             |

Figure 254. Carrier trailer brake valve, exploded

- (2) Clean all air passages with compressed air, making certain that they are clean and free of obstructions and foreign matter.

*b. Inspection and Repair.*

- (1) Inspect the bore in the body for scoring and scratches. The bore must be smooth to prevent damage to the piston. Replace a defective body.
- (2) Inspect the piston for rough spots and other damage. Check the fit of the piston stem in the cam. The piston stem must be a free sliding fit.
- (3) Inspect the inlet and exhaust valve for grooves, pitting, and other damage. Check the fit of the valve in the adjusting ring nut. The valve must slide freely without binding. Replace a defective inlet and exhaust valve.
- (4) Inspect the inlet valve seat in the body and the exhaust valve seat in the piston for grooves, pitting, corrosion, wear, and other damage. Replace defective body and piston.
- (5) Inspect all parts for cracks, breaks, bends, damaged threads, corrosion, distortion, and other damage. Repair or replace damaged parts as necessary.

### 521. Carrier Trailer Brake Valve Reassembly and Installation

*a. Reassembly.* Reassemble the carrier trailer brake valve in the reverse of the numerical sequence as instructed on figure 254.

*b. Installation.* Install the carrier trailer brake valve on the crane carrier.

## Section LIX. CARRIER AIR BRAKE PROTECTION VALVE ASSEMBLY

### 522. General

The carrier air brake protection valve assembly and the carrier air brake protection control valve assembly form the carrier air brake protection system. The trailer service and emergency lines pass through the carrier protection valve. Should a condition arise resulting in the air loss from either the carrier or trailer system, with the carrier protection control valve in the NORMAL position, the carrier protection valve will automatically close the air lines leading to the trailer and apply the trailer brakes.

### 523. Carrier Air Brake Protection Valve Assembly Removal and Disassembly

a. *Removal.* Remove the carrier air brake protection valve assembly (para. 236).

b. *Disassembly.* Disassemble the carrier air brake protection valve assembly in numerical sequence as illustrated on figure 255.

### 524. Carrier Air Brake Protection Valve Assembly Cleaning, Inspection, and Repair

a. *Cleaning.* Clean all parts with an approved cleaning solvent and dry thoroughly.

b. *Inspection and Repair.* Inspect all parts for excessive wear and damage. Replace or repair all defective parts.

### 525. Carrier Air Brake Protection Valve Assembly Reassembly and Installation

a. *Reassembly.* Reassemble the carrier air brake protection valve assembly in the reverse of the numerical sequence as illustrated on figure 255.

b. *Installation.* Install the carrier air brake protection valve assembly (para. 236).

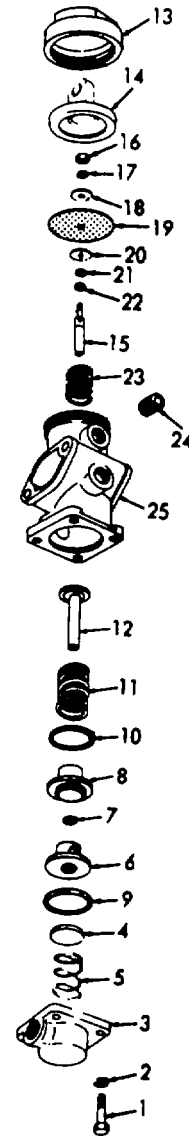

MEC 3810-227-15/255

1	Screw, cap	13	Capnut
2	Washer, lock	14	Caps
3	Cover	15	Plunger
4	Disk valve	16	Nut
5	Spring	17	Washer
6	Valve seat	18	Follower
7	Packing	19	Diaphragm
8	Valve guide	20	Follower
9	Packing	21	Washer
10	Packing	22	Packing
11	Spring	23	Spring
12	Service and exhaust valve	24	Plug, pipe
		25	Body

Figure 255. Carrier air brake protection valve assembly

## Section LX. CARRIER AIR BRAKE RELAY ASSEMBLY

### 526. General

The carrier air brake relay valve assembly is located in the carrier air brake system between the air receiver tanks and the rear air brake chambers. The relay valve speeds up the application and release of the rear wheel brakes. It is controlled by the brake control valve and keeps the air pressure in the rear brake chambers the same as the pressure being delivered by the brake control valve.

### 527. Carrier Air Brake Relay Valve Assembly Removal and Disassembly

a. *Removal.* Remove the carrier air brake relay valve assembly (para. 238).

b. *Disassembly.* Disassemble the carrier air brake relay valve assembly in numerical sequence as illustrated on figure 256.

### 528. Carrier Air Brake Relay Valve Assembly Cleaning, Inspection, and Repair

a. *Cleaning.* Clean all parts with an approved cleaning solvent and dry thoroughly.

b. *Inspection ad Repair.* Inspect all parts for excessive wear and damage. Replace or repair all defective parts.

### 529. Carrier Air Brake Relay Valve Assembly Reassembly and Installation

a. *Reassembly.* Reassemble the carrier air brake relay valve assembly in the reverse of the numerical sequence as illustrated on figure 256.

b. *Installation.* Install the carrier air brake relay valve assembly (para. 238).

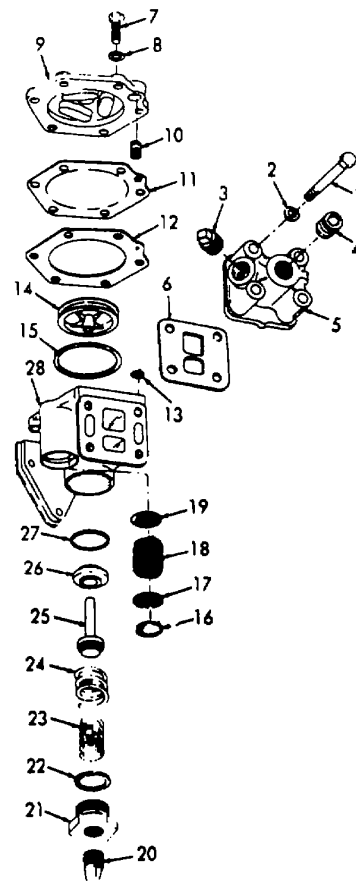

MEC 3810-227-15/256

1 Screw, cap	15 Packing
2 Washer, flat	16 Snap ring
3 Plug, pipe	17 Strainer plate
4 Plug, pipe	18 Exhaust strainer
5 Adapter	19 Strainer plate
6 Gasket	20 Plug, pipe
7 Screw, cap	21 Capnut
8 Washer, flat	22 Packing
9 Cover	23 Spring
10 Filter	24 Spring
11 Diaphragm	25 Supply valve
12 Diaphragm ring	26 Valve seat
13 Packing	27 Packing
14 Diaphragm guide	28 Valve body

Figure 256. Carrier air brake relay valve assembly, exploded view.

## Section LXI. CARRIER STEERING HYDRAULIC PUMP ASSEMBLY

### 530. General

The carrier steering hydraulic pump assembly is mounted on the front end of the carrier 288 engine cylinder block, just behind the fan assembly. The pump is

belt driven from the carrier water pump and fan pulley. The output

of the hydraulic pump is delivered to a pressure control valve which in turn supplies the hydraulic cylinder with the necessary power for steering.

### 531. Carrier Steering Hydraulic Pump Assembly Removal and Disassembly

a. *Removal.* Remove the carrier steering hydraulic pump assembly (para. 218).

b. *Disassembly.* Disassemble the carrier steering hydraulic pump assembly in numerical sequence as illustrated on figure 257.

### 532. Carrier Steering Hydraulic Pump Assembly Cleaning, Inspection and Repair

a. *Cleaning.* Clean all parts with an approved cleaning solvent and dry thoroughly.

b. *Inspection and Repair.* Inspect all parts for excessive wear and damage. Replace repair all defective parts.

### 533. Carrier Steering Hydraulic Pump Assembly Reassembly and Installation

a. *Reassembly.* Reassemble the carrier steering hydraulic pump assembly in the reverse of the numerical sequence as illustrated on figure 257.

b. *Installation.* Install the carrier steering hydraulic pump assembly (para. 218).

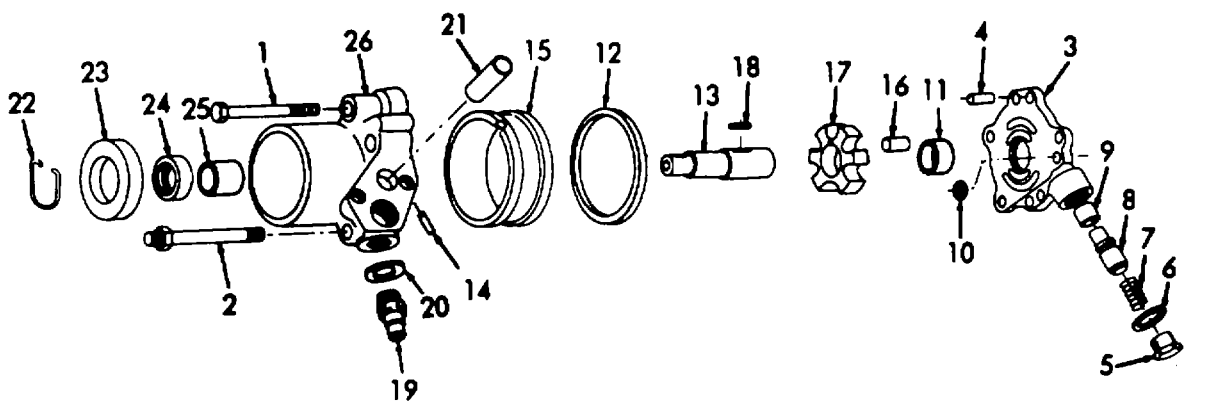

MEC 3810-227-15/257

- |                          |                  |                  |              |
|--------------------------|------------------|------------------|--------------|
| 1 Screw, cap             | 8 Valve assembly | 15 Cam ring      | 22 Snap ring |
| 2 Stud, and nut assembly | 9 Tube seat      | 16 Roll          | 23 Bearing   |
| 3 Cover body             | 10 Packing       | 17 Carrier       | 24 Seal      |
| 4 Dowel pin              | 11 Bushing       | 18 Drive pin     | 25 Bushing   |
| 5 Valve cap              | 12 Packing       | 19 Adapter       | 26 Base body |
| 6 Packing                | 13 Shaft         | 20 Gasket        |              |
| 7 Spring                 | 14 Dowel pin     | 21 Flow director |              |

Figure 257. Carrier steering hydraulic pump assembly, exploded view.

## Section LXII. CARRIER STEERING HYDRAULIC CONTROL VALVE ASSEMBLY

### 534. General

The carrier steering hydraulic control valve assembly is mounted on the lower side of the carrier steering gear assembly. The valve is the control center of the hydraulic steering gear. When the steering wheel is turned, the actuator in the steering gear assembly moves the

actuating lever of the steering control valve so hydraulic oil pressure from the hydraulic steering pump is directed to the steering cylinder giving the desired amount and direction of wheel turn.



**535. Carrier Steering Hydraulic Control Valve Assembly Removal and Disassembly**

- a. Removal. Remove the carrier steering hydraulic control valve assembly (para. 217).
- b. *Disassembly.* Disassemble the carrier steering hydraulic control valve assembly in numerical sequence as illustrated on figure 259.

**536. Carrier Steering Hydraulic Control Valve Assembly Cleaning, Inspection and Repair**

- a. *Cleaning.* Clean all parts with an approved cleaning solvent and dry thoroughly.

- b. *Inspection and Repair.* Inspect all parts for excessive wear and damage. Replace or repair all defective parts.

**537. Carrier Steering Hydraulic Control Valve Assembly Reassembly and Installation**

- a. *Reassembly.* Reassemble the carrier steering hydraulic control valve assembly in the reverse of the numerical sequence as illustrated on figure 259.
- b. *Installation.* Install the carrier steering hydraulic control valve assembly (para. 217).

**Section LXIII. CARRIER STEERING HYDRAULIC CYLINDER ASSEMBLY**

**538- General**

The carrier steering hydraulic cylinder assembly is a steering aid mounted on the top side of the steering gear assembly. The hydraulic steering cylinder enables the operator to have effortless control of the carrier under all adverse conditions that may be due to excessive loads or road conditions.

**539. Carrier Steering Hydraulic Cylinder Assembly Removal and Disassembly**

- a. Remove and disassemble the carrier steering hydraulic cylinder assembly in numerical sequence as shown in figure 259.

**540. Carrier Steering Hydraulic Cylinder Assembly Cleaning, Inspection and Repair**

- a. *Cleaning.* Clean all parts with an approved cleaning solvent and dry thoroughly.
- b. *Inspection and Repair.* Inspect all parts for excessive wear and damage. Replace or repair all defective parts.

**541. Carrier Steering Hydraulic Cylinder Assembly Reassembly and Installation**

- Reassemble and install the carrier steering hydraulic cylinder assembly in the reverse of the numerical sequence as illustrated on figure 259.

**Section LXIV. CARRIER STEERING COLUMN AND GEAR ASSEMBLY**

**542. General**

The steering assembly used on the carrier is a cam and lever type assembly. Manual operation of the steering wheel causes the camshaft to rotate in the gear assembly.

**543. Carrier Steering Column and Gear Assembly Removal and Disassembly**

- a. Removal.
  - (1) Remove the steering wheel (para. 219).

- (2) Remove the steering gear arm (para. 221).
- (3) Remove the turn signal switch (para. 122).
- (4) Remove the screws and clamp that secure the steering column to the instrument panel. Disconnect the universal shaft to the steering gear and remove the steering column.
- (5) Remove the carrier steering gear assembly as instructed on figure 258.

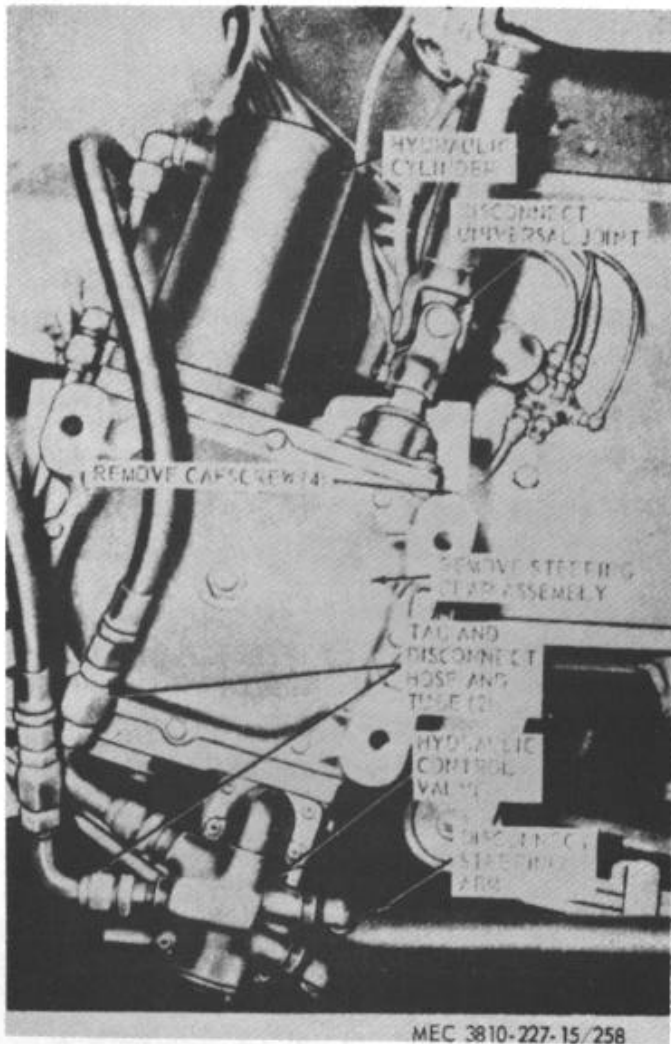

**Figure 258. Carrier steering gear assembly, removal and installation.**

**AGO 6819A**

*b. Disassembly.* Disassemble the carrier steering gear assembly in numerical sequence as illustrated on figure 259.

**544. Gear Assembly, Cleaning, Inspection and Repair Carrier Steering Column and**

*a. Cleaning.* Clean all parts with an approved cleaning solvent and dry thoroughly.

*b. Inspection and Repair.* Inspect all parts for excessive wear. Replace or repair all defective parts. Inspect shims between lever shaft and housing. Adjust shims pack to proper thickness. Shim pack should not be able to be turned by fingers through side cover.

**545. Carrier Steering Column and Gear Assembly Reassembly and Installation**

*a. Reassembly.* Reassemble the carrier steering gear assembly in the reverse of the numerical sequence as illustrated on figure 259.

*b. Installation.*

- (1) Install the carrier steering gear assembly as illustrated on figure 258.
- (2) Install the steering column and connect universal shaft to steering gear. Secure to instrument panel with clamp and screws.
- (3) Install the turn signal switch (para. 122).
- (4) Install the steering gear arm (para. 221).
- (5) Install the steering wheel (para. 219).

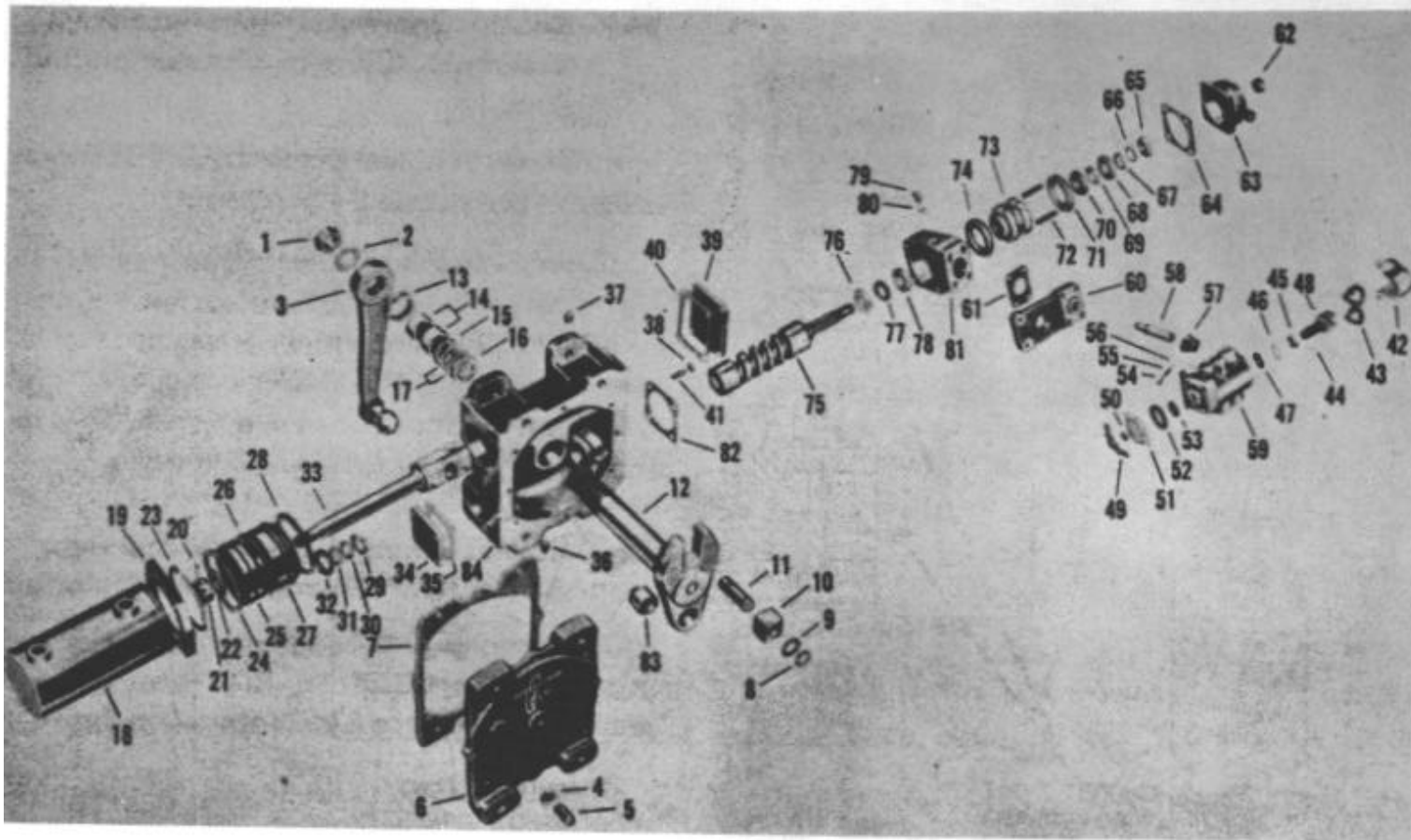

MEC 3810-227-15/259 ①

- |    |                            |    |                   |    |                          |
|----|----------------------------|----|-------------------|----|--------------------------|
| 1  | Lever shaft nut            | 29 | Retaining ring    | 57 | Lever seal               |
| 2  | Lockwasher                 | 30 | Seal washer       | 58 | Actuating lever          |
| 3  | Steering arm               | 31 | Back up washer    | 59 | Valve body & spool       |
| 4  | Lock nut                   | 32 | Seal              | 60 | Mounting bracket         |
| 5  | Adjusting screw            | 33 | Piston rod        | 61 | Gasket                   |
| 6  | Side cover                 | 34 | End cover         | 62 | Oil seal                 |
| 7  | Side cover gasket          | 35 | End cover gasket  | 63 | Upper cover              |
| 8  | Retaining ring             | 36 | Pipe plug         | 64 | Gasket                   |
| 9  | Washer                     | 37 | Pipe plug         | 65 | Adjusting nut            |
| 10 | Lever block                | 38 | Lock nut          | 66 | Lockwasher               |
| 11 | Lever block pin            | 39 | End cover         | 67 | Tongued washer           |
| 12 | Lever shaft                | 40 | Gasket            | 68 | Thrust washer            |
| 13 | Oil seal                   | 41 | Set screw         | 69 | Thrust bearing           |
| 14 | Bushings                   | 42 | Cover             | 70 | Thrust washer            |
| 15 | Washer, shim pack          | 43 | Cover seal        | 71 | Centering washer         |
| 16 | Retaining washer           | 44 | Cotter pin        | 72 | Centering springs        |
| 17 | Shims                      | 45 | Slotted nut       | 73 | Actuator                 |
| 18 | Cylinder                   | 46 | Lockwasher        | 74 | Centering washer         |
| 19 | Adapter                    | 47 | O-ring            | 75 | Cam assembly             |
| 20 | Cotter pin                 | 48 | Clevis rod        | 76 | Thrust washer            |
| 21 | Piston rod nut             | 49 | Retainer          | 77 | Thrust bearing           |
| 22 | Steel washer               | 50 | Seal              | 78 | Thrust washer            |
| 23 | Retaining ring             | 51 | Valve spool cover | 79 | Retainer screw           |
| 24 | Piston ring                | 52 | O-ring seal       | 80 | Seal washer              |
| 25 | Piston                     | 53 | O-ring            | 81 | Actuator housing         |
| 26 | O-ring seal                | 54 | Plug              | 82 | Gasket                   |
| 27 | Cylinder adapter & bushing | 55 | Spring            | 83 | Roller bearing stud unit |
| 28 | Cylinder gasket            | 56 | Steel ball        | 84 | Housing                  |

A—Steering gear assembly—Exploded view

Figure 259. Carrier steering gear assembly.

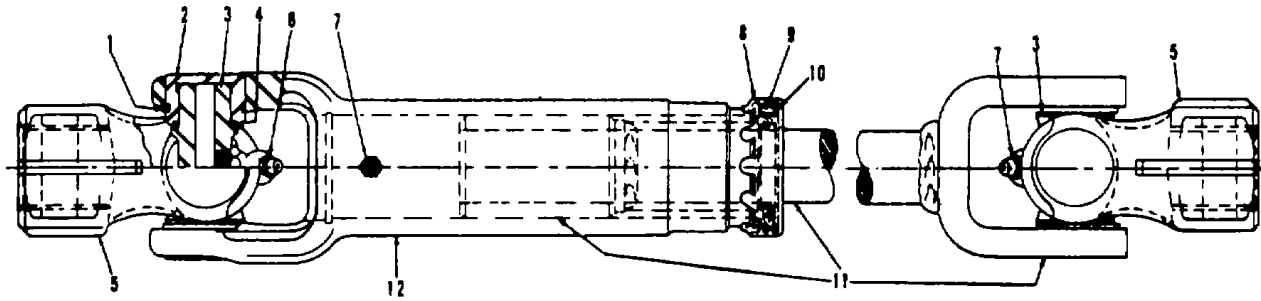

- |                |                |   |
|----------------|----------------|---|
| 1 Snap Ring    | 5 Yoke         | 9 Felt Washer                                 |
| 2 Bushing      | 6 Lube Fitting | 10 Metal Washer                               |
| 3 Center Cross | 7 Lube Fitting | 11 Yoke & Spline Plug Ass'y (1 1/4-32 Spline) |
| 4 Cork Washer  | 8 Dust Cap     | 12 Tube Ass'y (Yoke Tube)                     |

B—Universal shaft assembly

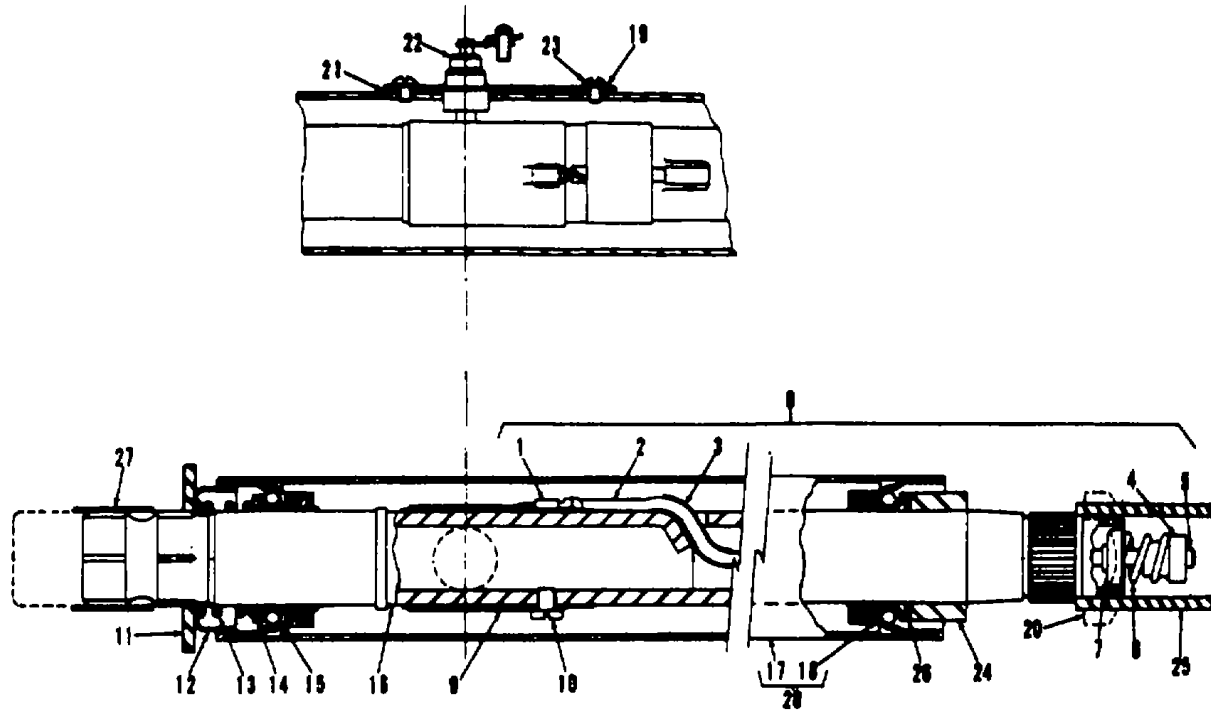

MEC 3810-227-15/259 (2)

- |                   |                      |                |                    |
|-------------------|----------------------|----------------|--------------------|
| 1 Terminal        | 8 Cable assy.        | 15 Bearing     | 22 Contact brush   |
| 2 Cable           | 9 Contact Ring assy. | 16 Shaft assy. | 28 Screw, rd hd.   |
| 3 Cable Insulator | 10 Screw             | 17 Column      | 24 Spacer          |
| 4 Ferrule         | 11 Washer            | 18 Bearing     | 25 Shipping sleeve |
| 5 Terminal        | 12 Dust cup          | 19 Lockwasher  | 26 Washer          |
| 6 Spring          | 13 Spring            | 20 Wheel nut   | 27 Shipping sleeve |
| 7 Contact cup     | 14 Washer            | 21 Spacer      | 28 Column assy.    |

C—Upper column assembly

Figure 259-Continued.

## Section LXV. CARRIER STEERING KNUCKLE AND SHAFT ASSEMBLY

### 546. General

The carrier steering knuckles are the trunion socket-type with universal joints. The power is delivered through the differential to the axle shafts and out through the constant velocity universal joints to the wheels. The front axle can be engaged to operate as a driving unit or disengaged to rotate freely by operating the control lever in the operator's cab.

### 547. Carrier Steering Knuckle and Shaft Assembly Removal and Disassembly

#### a. Removal.

- (1) Remove the front wheels (para. 224).
- (2) Remove the brakeshoes (para. 241).
- (3) Remove the tie rod drag links (paras.220 and 222).
- (4) Remove the carrier steering knuckle and shaft assembly as instructed on figure 260.

b. *Disassembly.* Disassemble the carrier steering knuckle and shaft assembly in numerical sequence as illustrated on figure 261.

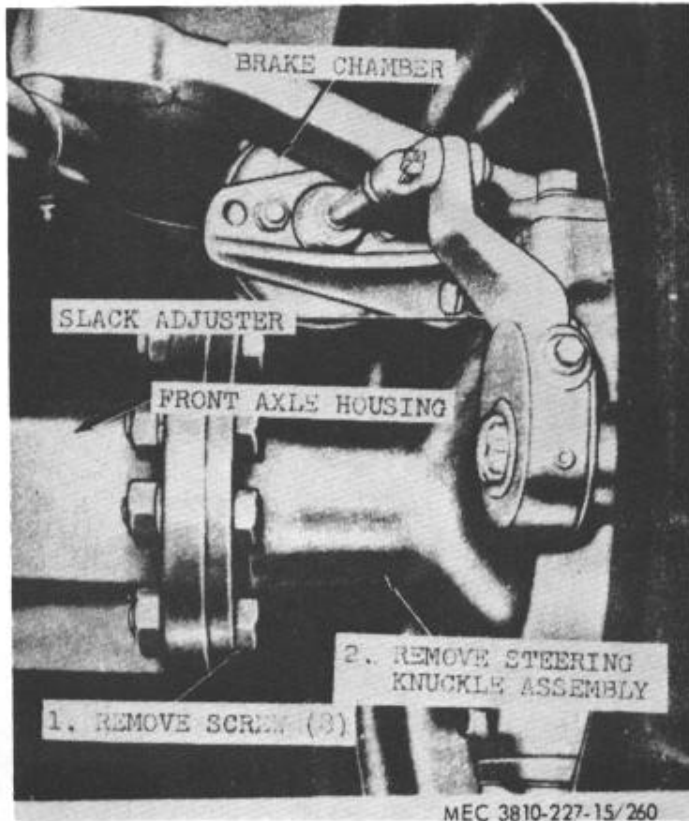

Figure 260. Carrier steering knuckle and shaft-assembly, removal and installation.

AGO 6819A

### 548. Carrier Steering Knuckle and Shaft Assembly, Cleaning, Inspection, and Repair

a. *Cleaning.* Clean all parts with an approved cleaning solvent and dry thoroughly.

b. *Inspection and Repair.* Inspect all parts for excessive wear and damage. The proper adjustment of the steering knuckle flange bearings is accomplished by the shims located under the flange bearing caps. Remove shims under each cap until there is no end play in the knuckle assembly. After 0.005 inch shims is removed there should be a small amount of drag in rotating the steering knuckle, but it should not bind. Replace or repair all defective parts.

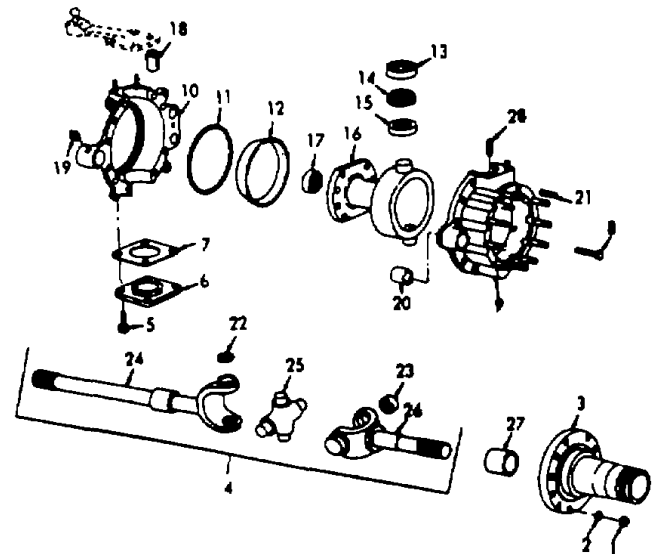

MEC 3810-227-15/261

- |                              |                         |
|------------------------------|-------------------------|
| 1 Nut                        | 15 Grease retainer      |
| 2 Washer, lock               | 16 Trunion socket       |
| 3 Hub                        | 17 Drive shaft oil seal |
| 4 Axle shaft assembly        | 18 Pin                  |
| 5 Screw, cap                 | 19 Fitting, lubrication |
| 6 Steering bearing lower cap | 20 Camshaft, bushing    |
| 7 Shim                       | 21 Stud                 |
| 8 Screw, cap                 | 22 Lockring             |
| 9 Front steering flange      | 23 Universal bearing    |
| 10 Rear steering flange      | 24 Long axle shaft      |
| 11 Socket oil snap ring      | 25 Universal joint      |
| 12 Socket oil seal washer    | 26 Short axle shaft     |
| 13 Steering knuckle cup      | 27 Bushing              |
| 14 Steering knuckle cone     | 28 Stud                 |

Figure 261. Carrier steering knuckle and shaft, exploded view.

**549. Carrier Steering Knuckle and Shaft Assembly Reassembly and Installation**

- a. *Reassembly.* Reassemble the carrier steering knuckle and shaft assembly in the reverse of the numerical sequence as illustrated on figure 261.
- b. *Installation.*

- (1) Install the carrier steering knuckle and shaft assembly as illustrated on figure 260.
- (2) Install the tie rod drag links (paras. 220 and 222).
- (3) Install the brakeshoes (para. 241).
- (4) Install the front wheels (para. 224).

**Section LXVI. CARRIER FRONT DIFFERENTIAL ASSEMBLY**

**550. General**

The carrier front differential assembly is of the double reduction type. Both gear sets are mounted on tapered roller bearings. The bevel pinion gear drives the bevel gear which, being on a common shaft with the spur pinion gear, drives the differential spur pinion gear which drives the differential gear.

Inspect the contact of the bevel gear and pinion teeth for correct backlash of 0.014 to 0.020 inch. The spur gear runout should not exceed 0.008 inch.

**551. Carrier Front Differential Assembly Removal and Disassembly**

**553. Carrier Front Differential Assembly Reassembly and Installation**

- a. *Removal.*
  - (1) Remove the propeller shaft (para. 244).
  - (2) Drain the axle housing.
  - (3) Remove the steering knuckle and shaft assembly (para. 547).
  - (4) Remove the carrier front differential assembly as instructed on figure 262.

- a. *Reassembly.* Reassemble the carrier front differential assembly in the reverse of the numerical sequence as illustrated on figure 263.

- b. *Disassembly.* Disassemble the carrier front differential assembly in numerical sequence as illustrated on figure 263.

- b. *Installation.*
  - (1) Install the carrier front differential assembly as illustrated on figure 262.
  - (2) Install the steering knuckle and shaft assembly (para. 549).
  - (3) Fill the axle housing.
  - (4) Install the propeller shaft (para. 244).

**552. Carrier Front Differential Assembly Cleaning, Inspection and Repair**

- a. *Cleaning.* Clean all parts with an approved cleaning solvent and dry thoroughly.
- b. *Inspection and Repair.* Inspect all parts for excessive wear and damage. Replace or repair all defective parts. Check the pre-load torque of the cross shaft bearing. The correct pre-load torque of 5 to 15 pound-inches can be obtained by adding or removing shims under the bearing cage on the opposite side of the bevel gear. Check the pinion gear shaft bearing for correct pre-load of 5 to 15 pound-inches.

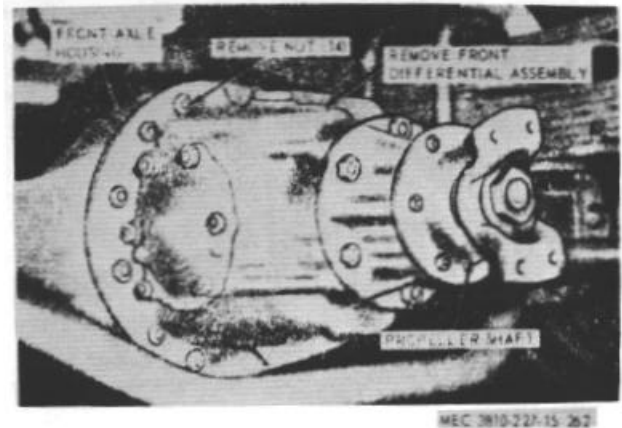

**Figure 262. Carrier front differential assembly, removal and installation.**

Section LXVII. CARRIER FRONT SPRING ASSEMBLY

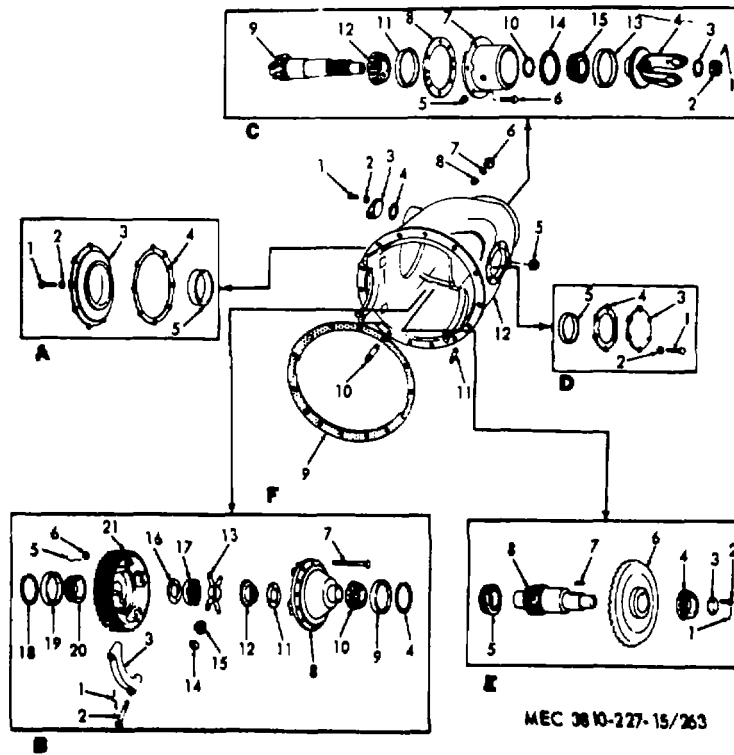

554. General

The two front spring assemblies, one on each side, are mounted with the arch down. A hanger is welded to the frame side rail. The rear end of the spring lies in the hanger. An eye on the front end of the spring is pinned to the hanger welded on the frame side rail. The spring leaves are held together by a bolt through the center of each leaf. The leaves are held in alignment with two clips. The front axle is secured to each spring with a pair of U-bolts.

- |                |                     |
|----------------|---------------------|
| 1 Pin, cotter  | 9 Pinion gear shaft |
| 2 Nut          | 10 Spacer           |
| 8 Washer, flat | 11 Bearing cup      |
| 4 Yoke         | 12 Bearing cone     |
| 5 Breather     | 18 Oil seal         |
| 6 Screw, cap   | 14 Bearing cup      |
| 7 Bearing cage | 15 Bearing cone     |
| 8 Shim         |                     |

C—Pinion gear shaft, yoke and bearing cage

- |                |               |
|----------------|---------------|
| 1 Screw, cap   | 4 Shim        |
| 2 Washer, flat | 5 Bearing cup |
| 3 Bearing cage |               |

D—Right side bearing cage and cup

- |                |               |
|----------------|---------------|
| 1 Screw, cap   | 4 Shim        |
| 2 Washer, flat | 5 Bearing cup |
| 3 Bearing cage |               |

A—Left side bearing cage and cup

- |                     |                          |
|---------------------|--------------------------|
| 1 Lockwire          | 12 Gear                  |
| 2 Screw, cap        | 13 Spider                |
| 3 Bearing cap       | 14 Thrust washer         |
| 4 Adjusting ring    | 15 Bevel pinion          |
| 5 Lockwire          | 16 Thrust washer         |
| 6 Nut               | 17 Gear                  |
| 7 Bolt              | 18 Adjusting ring        |
| 8 Differential case | 19 Bearing cup           |
| 9 Bearing cup       | 20 Bearing cone          |
| 10 Bearing cone     | 21 Helical gear and case |
| 11 Thrust washer    |                          |

B—Helical gear, spider and differential case

- |                 |                |
|-----------------|----------------|
| 1 Lockwire      | 5 Bearing cone |
| 2 Screw, cap    | 6 Bevel gear   |
| 3 Thrust washer | 7 Key          |
| 4 Bearing cone  | 8 Gearshaft    |

E—Gear and gearshaft

- |                |                         |
|----------------|-------------------------|
| 1 Screw, cap   | 7 Washer, lock, IET     |
| 2 Washer, lock | 8 Dowel                 |
| 3 Cover        | 9 Gasket                |
| 4 Gasket       | 10 Stud                 |
| 5 Plug         | 11 Stud                 |
| 6 Nut          | 12 Differential carrier |

F—Differential carrier

Figure 263. Carrier front axle housing and differential assembly, exploded view.

AGO 6819A

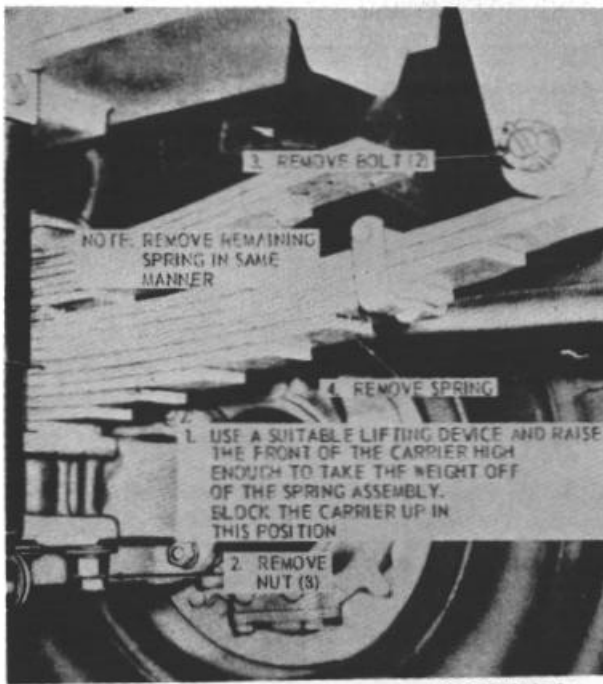

**Figure 264. Carrier front spring and axle assembly, removal and installation.**

**555. Carrier Front Spring Assembly Removal and Disassembly**

- a. *Removal.* Remove the carrier front spring assembly as instructed on figure 264.
- b. *Disassembly.* Disassemble the carrier front spring assembly as illustrated on figure 265.

**556. Carrier Front Spring Assembly Cleaning, Inspection, and Repair**

- a. *Cleaning.* Clean all parts with an approved cleaning solvent and dry thoroughly.
- b. *Inspection and Repair.* Inspect all parts for excessive wear or damage. Replace or repair all defective parts.

**557. Carrier Front Spring Assembly Reassembly and Installation**

- a. *Reassembly.* Reassemble the carrier front spring assembly as illustrated on figure 265.
- b. *Installation.* Install the carrier front spring assembly as illustrated on figure 264.

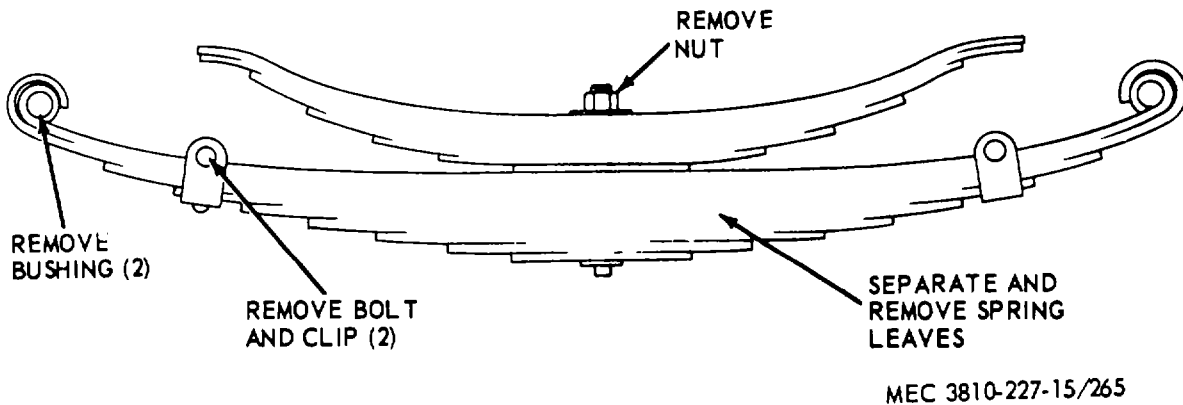

**Figure 265. Carrier Front spring assembly.**

**Section LXVIII. TORQUE ROD ASSEMBLY**

**558. General**

Each rear axle of the carrier has an automotive-type torque rod; one end attached to the upper axle housings and the other end of the torque rod is attached to the

carrier at the rear saddle bracket. The ball stud and socket assembly of the torque rod is so designed that the torque generated at the axle is minimized at the frame.

AGO 6819A



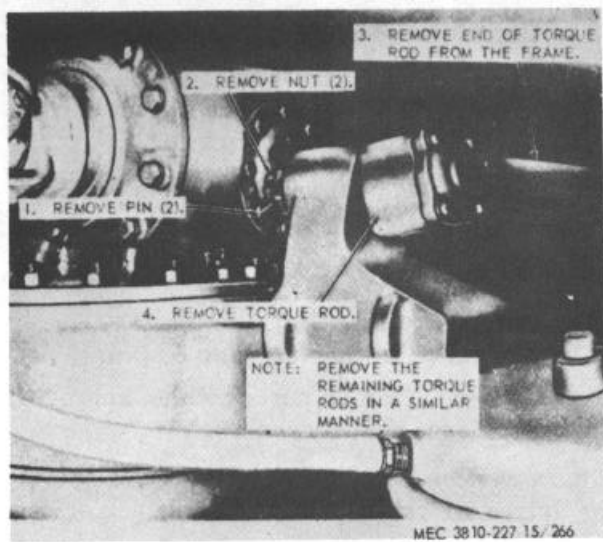

Figure 266. Torque rod assembly, removal and installation.

**559. Torque Rod Assembly Removal and Disassembly**

- a. *Removal.* Remove the torque rod assembly as instructed on figure 266.
- b. *Disassembly.* Disassemble the torque rod assembly in numerical sequence as instructed on figure 267.

**560. Torque Rod Assembly Cleaning and Inspection**

- a. *Cleaning.* Clean all parts with an approved cleaning solvent and dry thoroughly.
- b. *Inspection.* Inspect all parts for excessive wear and damage. Replace all defective parts as necessary.

**561. Torque Rod Assembly Reassembly and Installation**

- a. *Reassembly.* Reassemble the torque rod assembly in the reverse of the instructions on figure 267.

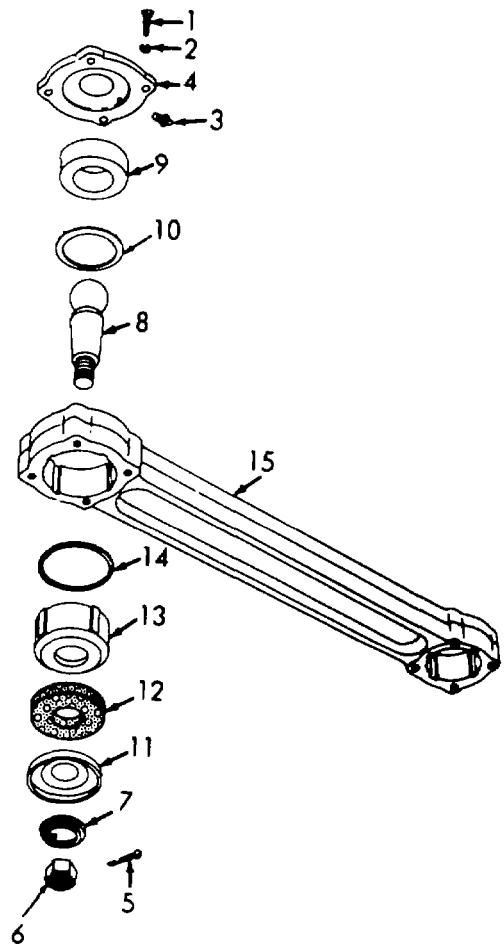

MEC 38 10-227-15/267

- |                        |                        |
|------------------------|------------------------|
| 1 Screw, cap           | 9 Plain ball socket    |
| 2 Washer, lock         | 10 Shim                |
| 3 Fitting, lubrication | 11 Retainer            |
| 4 Torque rod cap       | 12 Socket felt         |
| 5 Pin, cotter          | 13 Grooved ball socket |
| 6 Nut                  | 14 Shim, 0.005 in.     |
| 7 Spring               | 15 Torque rod          |
| 8 Ball stud            |                        |

Figure 267. Torque rod assembly, exploded view.

- b. *Installation.* Install the torque rod assembly as illustrated on figure 266.

**Section LXIX. EQUALIZING BEAM ASSEMBLY**

**562. General**

Two equalizing beams serve as the rear suspension for the carrier frame and rear axles to which each end of the beams are bolted. The ball and socket axle

mounted beam ends provide axle movement independent of the carrier frame, since the vertical movement of either wheel or axle is about the center mounting of

the beam where it is bolted to the carrier and pivots or turns on its center sleeve and bushing.

### 563. Equalizing Beam Assembly Removal and Disassembly

a. *Removal.* Remove the equalizing beam assembly as instructed on figure 268.

b. *Disassembly.* Disassemble the equalizing beam assembly in numerical sequence as instructed on figure 269.

### 564. Equalizing Beam Assembly Cleaning and Inspection

a. *Cleaning.* Clean all parts with an approved cleaning solvent and dry thoroughly.

b. *Inspection.* Inspect all parts for excessive wear and damage. Replace or repair all defective parts.

### 565. Equalizing Beam Assembly Reassembly and Installation

a. *Reassembly.* Reassemble the equalizing beam assembly in numerical sequence as instructed on figure 269.

b. *Installation.* Install the equalizing beam assembly as illustrated on figure 268.

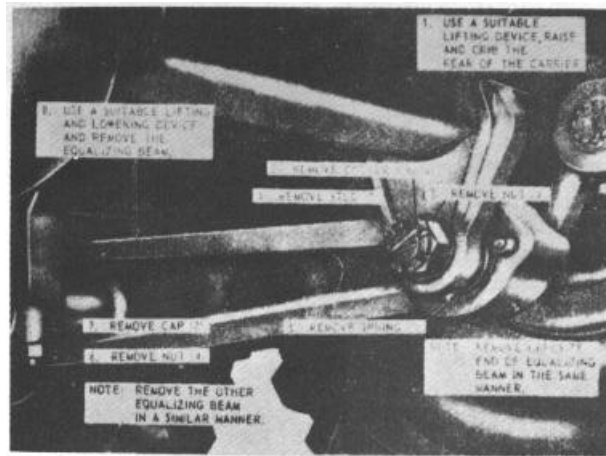

Figure 268. Equalizing beam assembly, removal and installation.

## Section LXX. CARRIER REAR, REAR AXLE DIFFERENTIAL ASSEMBLIES

### 566. General

The forward rear and rear axles are top mounted double-reduction drive units. The through shafts of the hypoid gear drive units are supported at the forward end by tapered roller bearings and at the rear end by a straight roller bearing. Pinion bearing preload is adjusted and maintained by a hardened precision spacer between the inner and the outer tapered bearings. The front rear through-shaft is splined on both ends while the rear one is not splined on both ends.

### 567. Carrier Rear, Rear Axle Differential Assemblies, Removal and Disassembly

- a. *Removal.*
- (1) Disconnect the propeller shafts (para. 244).
  - (2) Remove the rear airbrake lines (para. 232).
  - (3) Drain the two axle housing.
  - (4) Disconnect the torque rods (para. 559).
  - (5) Disconnect the equalizer beams (para. 563).

AGO 6819A

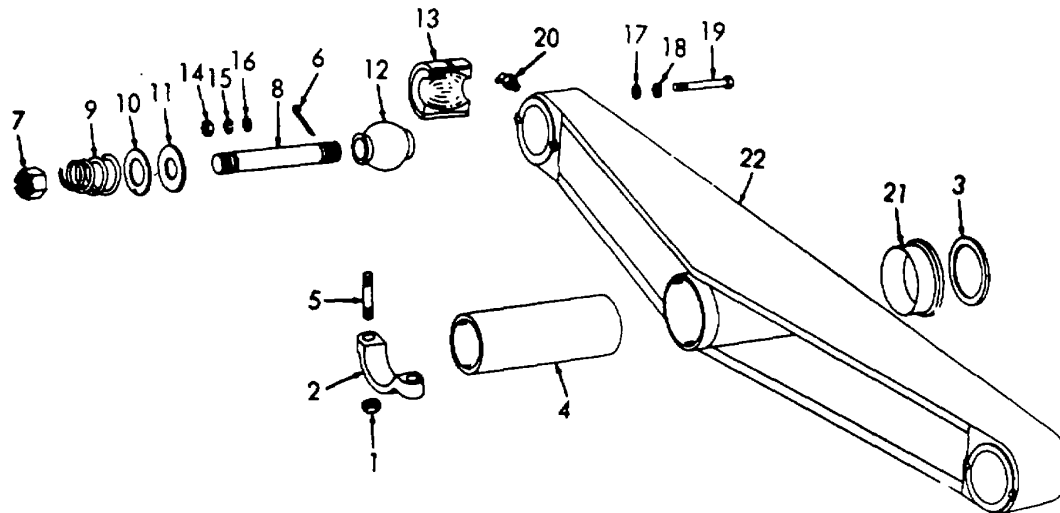

MEC 38 10-227-15/269

1 Nut	7 Nut, castellated	13 Beam socket half	19 Screw, cap
2 Saddle cap	8 Stud	14 Nut	20 Fitting, lubrication
3 Thrust washer	9 Spring	15 Washer, lock	21 Center bushing
4 Beam center sleeve	10 Felt retainer	16 Locking washer	22 Equalizing beam
5 Stud	11 Ball felt	17 Locking washer	
6 Pin, cotter	12 Beam ball	18 Washer, lock	

Figure 269. Equalizing beam assembly exploded view.

- (6) Use a suitable lifting device to raise the carrier, and roll the rear axle assemblies from under the carrier. Block the carrier up in this position.
- (7) Remove the rear axles (para. 227).
- (8) Remove the carrier rear axle differential assemblies as instructed on figure 270.

*b. Disassembly.* Disassemble the carrier rear axle differential assemblies in numerical sequence as illustrated on figure 271.

#### 568. Carrier Rear, Rear Axle Differential Assemblies, Cleaning, Inspection, and Repair

*a. Cleaning.* Clean all parts with an approved cleaning solvent and dry thoroughly.

*b. Inspection and Repair.* Inspect all parts for excessive wear and damage. The pre-load torque for bearings mounted in bearing cage is 5 to 15 pounds-inch. Install or remove shims between bearing cage and

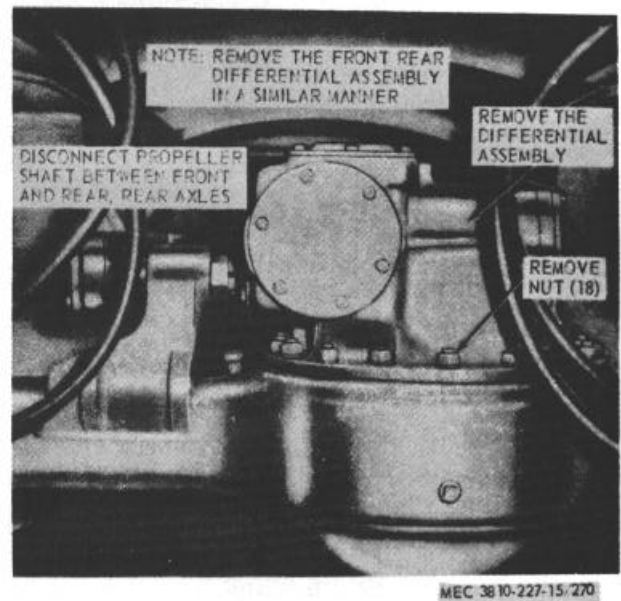

Figure 270. Carrier rear axle differential assembly, removal and installation

cover to attain proper bearing pre-load. When gear backlash is not specified on gear, set backlash to 0.006 to 0.012 inch. Replace gears in pairs. Replace or repair all damaged or defective parts.

**569. Carrier Rear, Rear Axle Differential Assemblies, Reassembly and Installation**

*a. Reassembly.* Reassemble the carrier rear axle differential assemblies in reverse of numerical sequence as illustrated on figure 271.

*b. Installation.*

- (1) Install the carrier rear axle differential assemblies as illustrated on figure 270.
- (2) Connect the equalizer beams (para. 565).
- (3) Connect the torque rods (para. 561).
- (4) Install the rear axle (para. 227).
- (5) Fill the two axle housings.

	1	Screw, cap	3	Differential cover	
	2	Washer, lock	4	Cover gasket	
	A-Differential cover				
1	Lockwire		12	Differential case	
2	Screw, cap		13	Drive helical gear	
3	Bearing, cap		14	Thrust washer	
4	Adjusting ring		16	Differential bevel gear	
5	Dowel		16	Thrust washer	
6	Lockwire		17	Differential bevel gear	
7	Castellated nut		18	Bevel pinion thrust washer	
8	Screw, cap		19	Spider bevel pinion	
9	Differential		20	Bevel pinion thrust washer	
10	Bearing cup		21	Spider bevel pinion	
11	Bearing cone		22	Differential spider	
	B-Differential spider, pinions, gears and case				
	1	Screw, cap	6	Spacer	
	2	Washer, lock	7	Roller bearing	
	3	Shaft cover	8	Bearing race	
	4	Cover gasket	9	Retaining ring	
	5	Retaining ring			
	C-Shaft cover and bearings				
1	Pin, cotter		11	Washer, lock	
2	Castellated nut		12	Screw, cap	
3	Washer, flat		13	Washer, lock	
4	Yoke		14	Bevel pinion bearing cage	
6	Dirt deflector		15	Shim	
6	Oil seal		16	Bearing cup	
7	Spacer		17	Spacer	
8	Bearing cone		18	Bearing cone	
9	Bearing cup		19	Bevel gear and pinion	
10	Screw, cap		20	Rear axle pinion shaft	
	D-Rear axle pinion shaft, bearing cage and yoke				
	1	Lockwire	5	Bearing cage	
	2	Screw, cap	6	Cage shim	
	3	Bearing cover	7	Gasket	
	4	Cover shim			
	E-Bearing case and cover				
	1	Plug, pipe	4	Cover	
	2	Screw, cap	6	Cover gasket	
	3	Washer, lock			
	F-Cover and gasket				
1	Lockwire		6	Bearing cup	
2	Screw, cap		7	Bearing cone	
3	Retaining washer		8	Helical pinion shaft	
4	Bearing cup		9	Machine key	
5	Bearing cone				
	G-Pinion shaft				
	1	Bearing washer	3	Bevel gear bearing	
	2	Bearing sleeve	4	Bevel gear	
	H-Bevel gear and bearing				
1	Gasket	2	Screw, set	3	Carrier assembly
	I-Carrier assembly and gasket				

**Figure 271. Carrier rear axle differential assembly.**

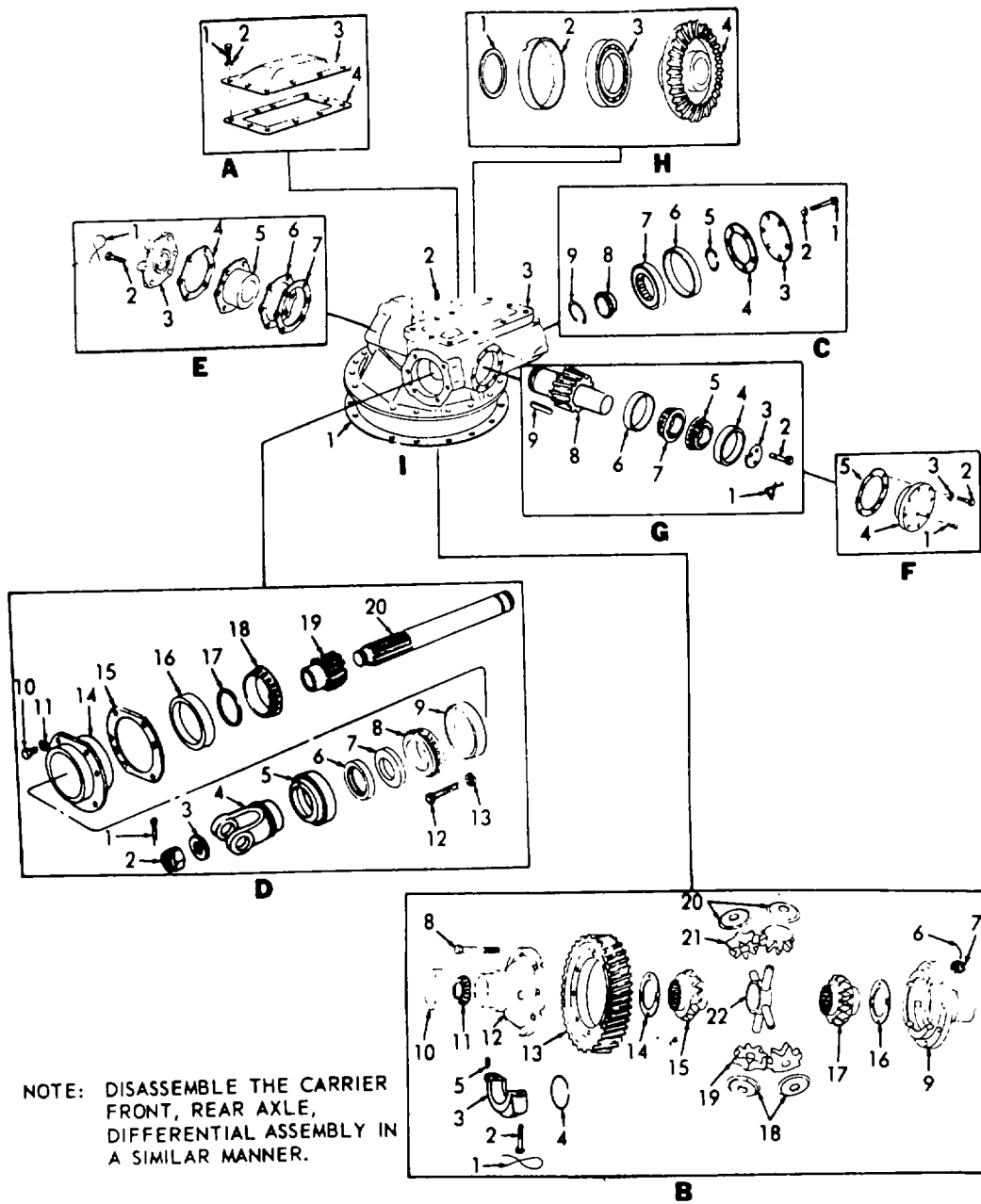

MEC 3810-227-15/271

Figure 271. - Continued.

**Section LXXI. CARRIER ENGINE AND CRANE ENGINE,  
LIQUID HEATER REPAIR INSTRUCTIONS**

**570. General**

The engine heaters for both carrier and crane are identical and repair instructions are the same for both units.

**571. Engine Liquid Heater Removal**

- a. Remove carrier engine liquid heater assembly (para. 267).

AGO 6819A

b. Remove crane engine liquid heater assembly (para. 278).

### 572. Engine Liquid Heater Disassembly

Disassemble the liquid heaters in numerical sequence as illustrated on figure 272.

### 573. Engine Liquid Heater, Cleaning, Inspection, and Repair

#### a. Cleaning.

- (1) Use a cloth dampened with an approved cleaning solvent and clean accumulated dirt from all heater parts.
- (2) Scrape carbon deposits and other foreign materials caused by combustion, being careful to avoid damaging the ceramic wick.
- (3) Clean all parts thoroughly to remove all accumulation of carbon, or restrictions.

#### b. Inspection and Repair.

- (1) Inspect burner and blower parts, combustion chamber, and casing for

cracked, burned, dented or otherwise damaged condition.

- (2) Replace faulty or defective parts.

### 574. Engine Liquid Heater Reassembly

a. *Reassembly.* Reassemble the engine liquid heaters in reverse of the numerical sequence as illustrated on figure 272.

#### b. Contact Gap Adjustment (fig. 273).

- (1) With the cam and contact plate assembled to the motor, rotate the motor shaft until the moveable contact is at the high point of the cam. Make sure the rubbing block of the moveable contact is between the teeth of the cam collar. At this position, a 0.025-in. feeler gage should just pass between the contacts.
- (2) If the gap needs adjusting, loosen the adjustable contact mounting screw and position the stationary contact to correct the contact gap. Tighten the mounting screw.

1	Screw, mach	55	Grommet	82	Screw, Pan-hd, mach
2	Cover, control hd.	66	Nut, cad pl	83	Washer, flat, brass
3	Nut	57	Nut, cad pl	84	Insulator, Post
4	Sleeve	58	Blower assembly, combustion	85	Bracket, terminal
6	Tube, fuel			86	Screw, set
6	Plug, pipe	59	Screw, cad pl	87	Fan assembly
7	Nozzle assembly	60	Cap	88	Shell assembly, combustion, air
8	Screw, mach.	61	Screw, set	89	Motor, electric
9	Nut, cad. pl.	62	Cam, set	90	Seal, tube
10	Switch, flame	63	Bushing, Cam (part of Item 62)	91	Screw, mach.
11	Head assembly, control 12-37 (See figure 272 B)	64	Collar, Cam (part of Item 62)	92	Nut
38	Screw, rd hd	65	Plate assembly	93	Washer, flat
39	Retainer, switch	66	Spacer	94	Band, connector
40	Switch, limit	67	Cam, contact	95	Nut, cad pl
41	Union	68	Screw, Pan-hd, mach.	96	Washer, insulator
42	Washer, Union Seal	69	Bracket, Capacitor (part of Item 70)	97	Insulator, Post
48	Seal, Union	70	Capacitor and Bracket	98	Insulator band connector
44	Gasket	71	Screw, Pan-hd, mach.	99	Preheater assembly
45	Spark Plug Assembly	72	Screw, Pan-hd, mach.	100	Gasket, Ignitor sleeve
46	Washer, spark plug	73	Contact Set	101	Burner assembly, complete
47	Seal, spark plug	74	Washer, lock, split	102	Screw, hex hd
48	Screw, mach.	75	Plate, contact	103	Nut, cad pl
49	Cover Assembly, Intake	76	Nut, hex	104	Base assembly
50	Screw, mach.	77	Washer, lock, ext tooth	105	Plug, pipe
51	Screw, rd-hd.	78	Nut, hex	106	Chamber assembly, combustion
52	Screw, hd.	79	Washer, lock, ext tooth		
53	Washer, special	80	Washer, flat, brass		
54	Casing Assembly	81	Washer, insulator		

A-Heater assembly

Figure 272. Engine liquid heater assembly.

AGO 6819A

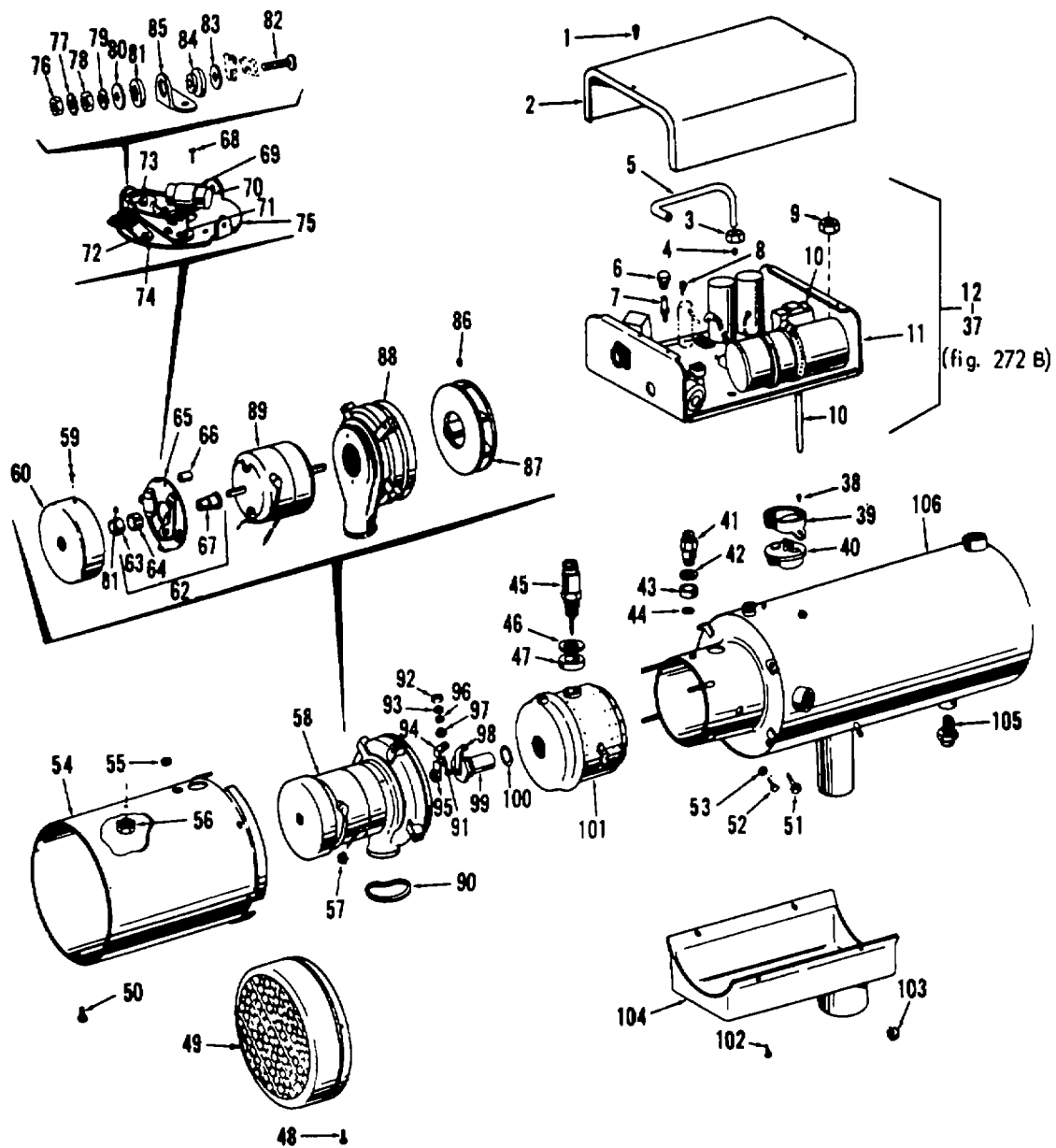

A - Heater Assembly.

MEC 3810-227-15/272 ①

Figure 272. - Continued

c. Flame Switch Adjustment (fig. 274).

(1) The adjusting screw is a spring-loaded screw at the open end of the switch frame. It adjusts the travel of the actuating pin of the switch.

(2) With the flame switch at room temperature, loosen the adjusting screw and/or nut until a distinct click is heard. Then tighten the screw until a second click occurs. At this point



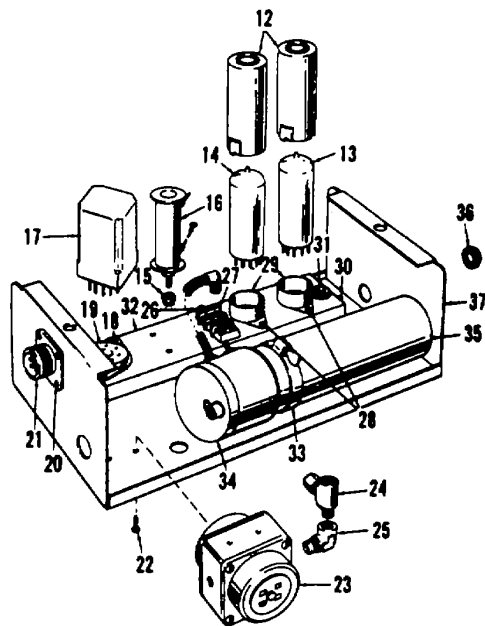

B - Control Head Sub-Assembly.

MEC 3810-227-15/272 ②

- 12 Shield, relay
- 13 Relay, time preheat (24v)
- 14 Relay, time, non-fire (24v)
- 15 Nut, acorn
- 16 Resistor assembly
- 17 Relay, power (24v)
- 18 Screw, mach.
- 19 Socket
- 20 Screw, self-tapping
- 21 Receptacle assembly
- 22 Screw, rd-hd
- 23 Valve assembly
- 24 Tee, adapter
- 25 Elbow, 90°, 1/8 NPT
- 26 Screw, mach.
- 27 Terminal block
- 28 Screw self-tapping
- 29 Socket, shield
- 30 Screw, st
- 31 Grommet
- 32 Base, relay mounting
- 33 Clamp, coil mounting
- 34 Cap-coil
- 35 Coil assembly, ignition
- 36 Grommet
- 37 Base assembly, control hd

B—Control Head Sub-assembly

Figure 272. - Continued

continue to tighten for three-eighths of a turn to correctly position the adjusting screw and/or nut.

d. *Flame Switch Test.*

- (1) At room temperature, check for continuity across terminals 2 and 4

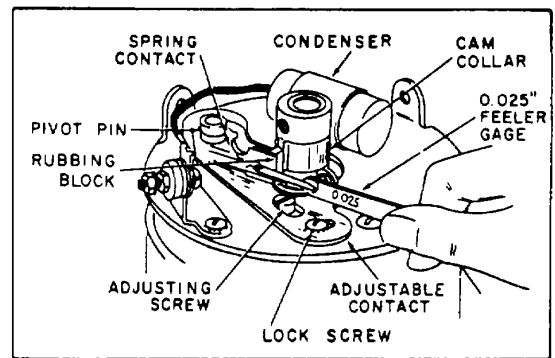

MEC 3810-227-15/273

Figure 273. Adjusting the contact plate point gap.

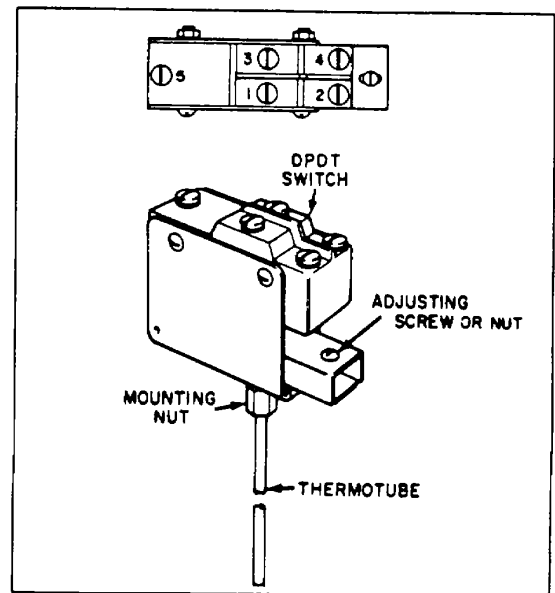

MEC 3810-227-15/274

Figure -274. Flame switch

and terminals 2 and 5 (fig. 274) with an ohmmeter. If continuity exists, continue the test.

- (2) Apply heat to the flame switch tube. The switch should change to hot position at 400° to 500° F. Continuity should now be across terminals 1 and

AGO 6819A

- 2 and 1 and 6. Allow the tube to cool. The switch should return to cold position at 200° to 300° F.
- (3) If a correctly adjusted switch does not meet these requirements, replace the flame switch.

## Section LXXII. CARRIER CAB AND CRANE CAB, FRESH AIR HEATER REPAIR INSTRUCTIONS

### 576. General

The cab fresh air heaters for both the carrier and crane are identical and repair instructions are the same for both units.

1	Screw, mach.	66	Washer, lock, E.T.
2	Cover, control hd	67	Nut, hex
3	Nut	68	Washer, lock, E.T.
4	Sleeve	69	Washer, flat
5	Tube, fuel	70	Washer, insulator
6	Plug, pipe	71	Screw, mach.
7	Nozzle assembly	72	Washer, flat
8	Screw, mach.	73	Insulator, Post
9	Switch, flame	74	Bracket, terminal
10	Grommet	75	Screw, mach.
11	Head assembly, control	76	Bracket, capacitor
12-37	(Refer to B figure 272)	77	Capacitor
38	Spark plug assembly	78	Contacts
39	Washer, spark plug	79	Screw, mach.
40	Seal, spark plug	80	Plate, contact
41	Cap	81	Fan assembly
42	Screw, rd-hd	82	Screw, special
43	Retainer, switch	83	Bumper, rubber
44	Switch, limit	84	Shell assembly
45	Screw, mach.	85	Spacer
46	Cover assembly, intake	86	Cam, contact
47	Screw, mach.	87	Motor, electric
48	Blower assembly, circulating air	88	Screw, mach.
49	Screw set	89	Nut, hex
50	Fan	90	Washer, flat
51	Screw, rd-hd	91	Washer, insulator
52	Clamp assembly, motor	92	Insulator, post
53	Motor, electric (24v)	93	Burner assembly
54	Nut, cad pl	94	Union
55	Blower assembly, combustion (24v)	95	Washer, union seal
56	Screw, cad pl. rd-hd	96	Seal, union
57	Cap, contact plate	97	Gasket
58	Screw, mach.	98	Grommet
59	Washer, lock	99	Grommet
60	Screw, set	100	Screw, hex hd
61	Bushing, cam	101	Base Assembly
62	Collar, cam	102	Seal, exhaust tube
63	Plate assembly	103	Screw, mach.
64	Screw, pan-hd	104	Screw, self-tapping
65	Nut, hex	105	Washer, special
		106	Chamber assembly
		107	Casing assembly

### 575. Engine Liquid Heater Installation

- Install carrier engine liquid heater assembly (para. 267).
- Install crane engine liquid heater assembly (para. 278).

### 577. Cab Fresh Air Heater Removal

- Remove carrier cab fresh air heater assembly (para. 270).
- Remove crane cab fresh air heater assembly (para. 281).

### 578. Cab Fresh Air Heater Disassembly

Disassemble the cab fresh air heaters in numerical sequence as illustrated on figure 276.

### 579. Cab Fresh Air Heater Cleaning, Inspection and Repair

#### a. Cleaning.

- Use a cloth dampened with an approved cleaning solvent and clean all heater parts.
- Scrape carbon deposits and other foreign materials caused by combustion, being careful to avoid damaging the ceramic wick.
- Clean all parts thoroughly to remove all accumulations of carbon restrictions.

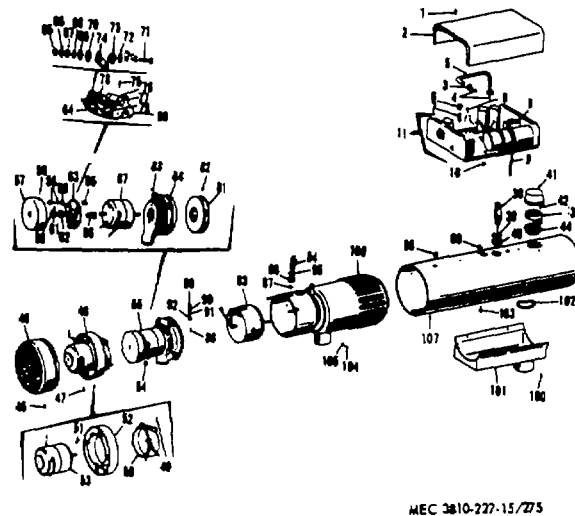

Figure 275. Cab fresh air heater assembly.

b. *Inspect and Repair.*

- (1) Inspect burner and blower parts, combustion chamber, and casing for cracked, burned, dented or otherwise damaged condition.
- (2) Replace faulty or defective parts.

**580. Cab Fresh Air Heater Reassembly**

a. *Reassembly.* Reassemble the cab fresh air heaters in reverse of the numerical sequence as illustrated on 275.

b. *Contact Gasp Adjustment.* Adjust contacts in a similar manner as described in paragraph 574b.

c. *Flame Suits Adjustment.* Adjust flame switch in a similar manner as described in paragraph 574c.

**581. Cab Fresh Air Heater Installation**

a. Install carrier cab fresh air heater assembly (para. 270).

b. Install crane cab fresh air heater assembly (para. 281).

**LXXIII. CRANE HYDRAULIC MASTER CYLINDER ASSEMBLIES AND CLUTCH CYLINDER ASSEMBLIES**

**582. General**

The master cylinder piston is connected to the control lever through linkage and when force is applied to the control lever it is transmitted to the master cylinder piston. The piston forces the fluid under pressure through the lines into the clutch cylinder, which moves the piston in the clutch cylinder outward actuating the clutch. When the master cylinder control lever is released or set in neutral position the clutch

release springs return the displaced fluid to the master cylinder.

**583. Crane Hydraulic Master Cylinder Assembly Removal and Disassembly**

a. *Removal.* Remove the master cylinder assembly (para. 180).

b. *Disassembly.* Disassemble the master cylinder assembly in numerical sequence as illustrated on figure 276.

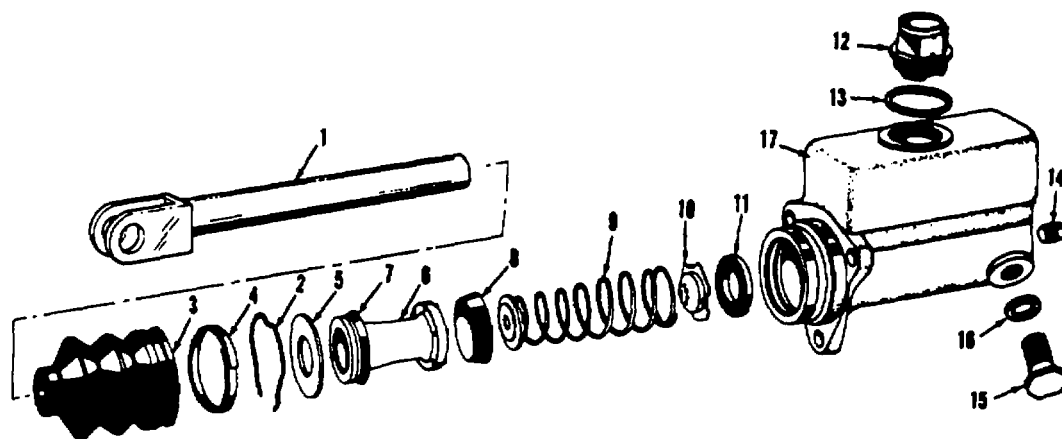

MEC 3810-227-15/276 ①

- |                   |                     |                      |
|-------------------|---------------------|----------------------|
| 1 Push rod        | 7 Secondary cup     | 13 Filler cap gasket |
| 2 Lockwire        | 8 Primary cup       | 14 Pipe plug         |
| 3 Boot            | 9 Return spring     | 15 Plug              |
| 4 Boot strap      | 10 Check valve      | 16 Plug gasket       |
| 5 Piston stop     | 11 Check valve seat | 17 Cylinder casting  |
| 6 Piston assembly | 12 Filler cap       |                      |

A—Master Cylinder

Figure 276. Crane hydraulic master cylinder, and clutch cylinder assemblies, exploded view.

AGO 6819A

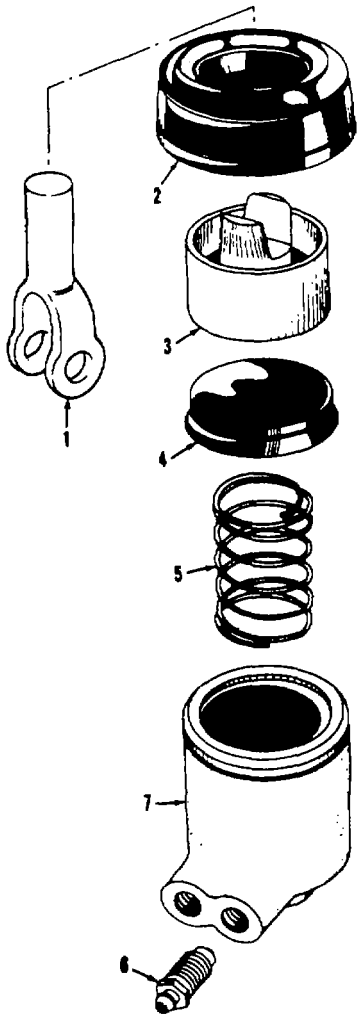

MEC 3810-227-15/276 ②

- |            |                    |
|------------|--------------------|
| 1 Push rod | 5 Spring           |
| 2 Boot     | 6 Bleeder Screw    |
| 3 Piston   | 7 Cylinder casting |
| 4 Cup      |                    |

B—Clutch cylinder

Figure 276. - Continued.

**584. Crane Hydraulic Master Cylinder  
Assembly Cleaning, Inspection, and  
Repair**

a. *Cleaning.* Clean all parts with an approved cleaning solvent and dry thoroughly. Cleanliness is of extreme importance when repairing hydraulic components.

b. *Inspection and Repair.* Inspect all parts for excessive wear or damage. Replace or repair all defective parts.

**585. Crane Hydraulic Master Cylinder  
Assembly Reassembly and Installation**

a. *Reassembly.* Reassemble the master cylinder assembly in the reverse of the numerical sequence as illustrated on figure 276.

b. *Installation.* Install the master cylinder assembly (para. 180).

**586. Crane Clutch Hydraulic Cylinder  
Assembly Removal and Disassembly**

a. *Removal.* Remove the crane clutch hydraulic cylinder assembly (para. 181).

b. *Disassembly.* Disassemble the crane clutch hydraulic cylinder assembly in numerical sequence as illustrated on figure 276.

**587. Crane Clutch Hydraulic Cylinder  
Assembly Cleaning, Inspection, and  
Repair**

a. *Cleaning.* Clean all parts with an approved cleaning solvent and dry thoroughly. Cleanliness is of extreme importance when repairing hydraulic components.

b. *Inspection and Repair.* Clean all parts with an approved cleaning solvent and dry thoroughly. Replace or repair all defective parts.

**588. Crane Clutch Hydraulic Cylinder  
Assembly Reassembly and Installation**

a. *Reassembly.* Reassemble the crane clutch hydraulic cylinder assembly in the reverse of the numerical sequence as illustrated on figure 276.

b. *Installation.* Install the crane clutch hydraulic cylinder assembly (para. 181).

AGO 6819A

## Section LXXIV. CRANE HOIST DRUM SHAFT

### 589. General

The crane hoist drum shaft is mounted uppermost on the revolving frame between the countershaft and the horizontal reversing shaft and is gear driven from the horizontal reversing shaft. It is secured to the frame by two bearing assemblies which are bolted to the frame. The cable drums are held stationary by the brakes until the individual clutch assembly is engaged, which in turn rotates the clutch and brake drum. The hoist drum shaft assembly can be removed as a unit without disturbing the countershaft or horizontal reversing shaft.

### 590. Crane Hoist Drum Shaft Assembly Removal and Disassembly

#### a. Removal.

- (1) Remove the crane cab assembly (para. 296).
- (2) Remove the primary drive chain case cover (para. 196).
- (3) Remove the gear and chain guards (para. 197).
- (4) Remove the brake band assemblies (para. 192).

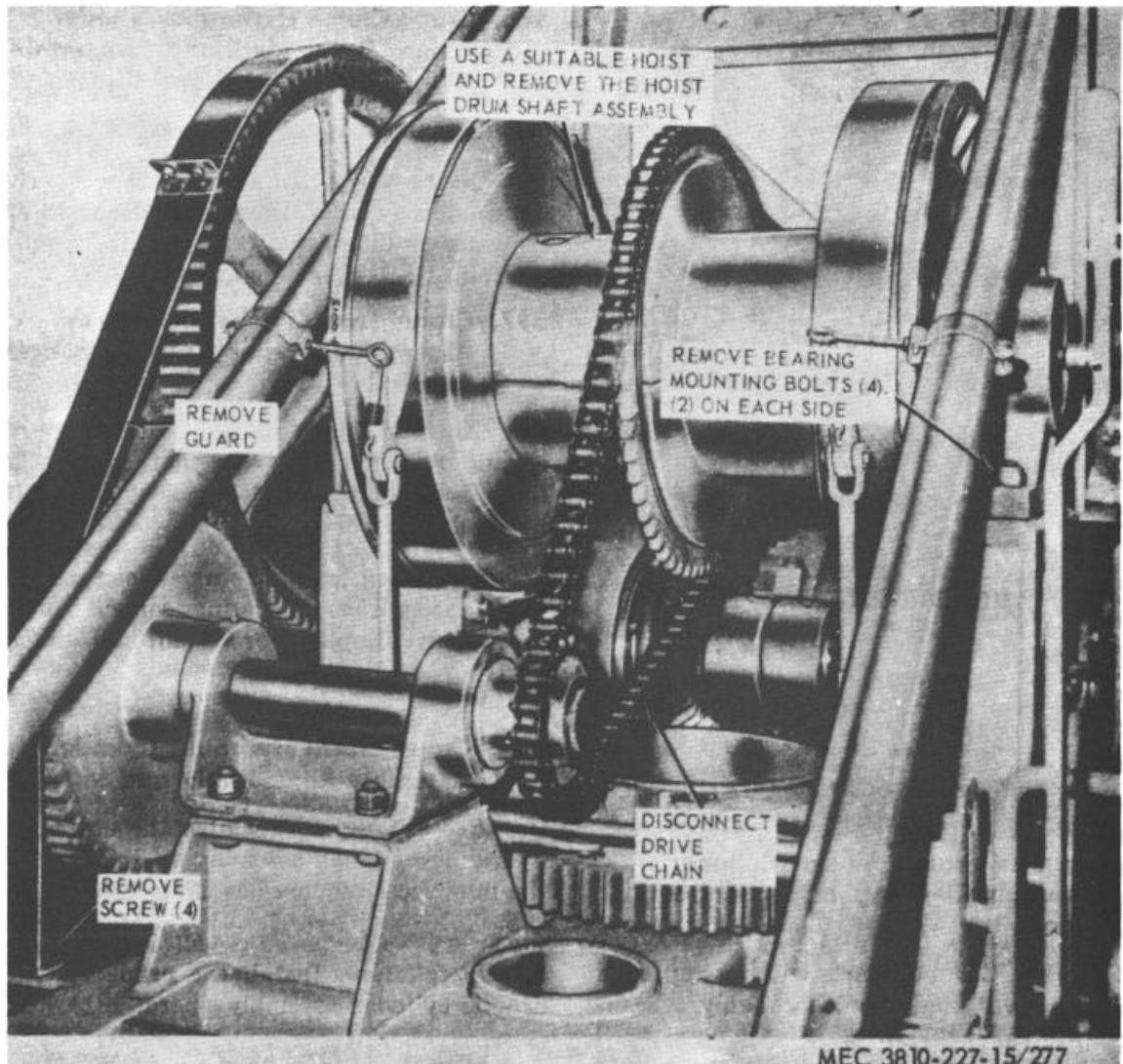
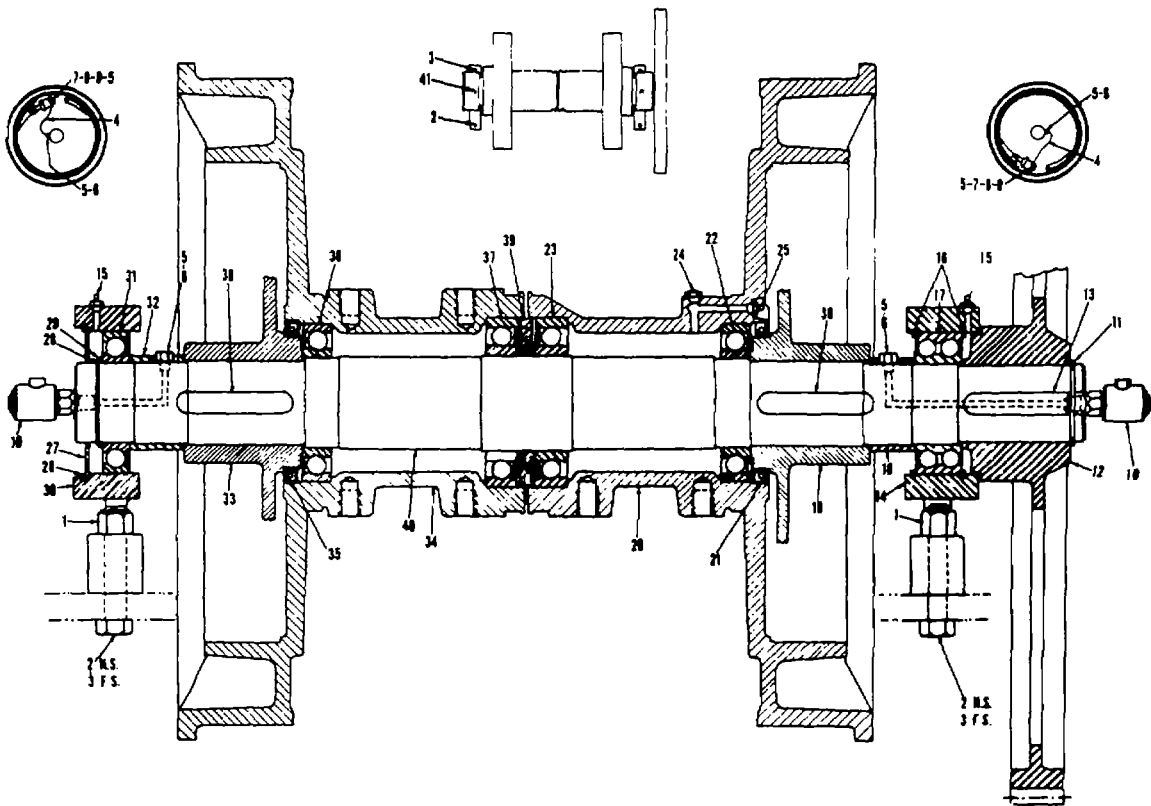

Figure 277. Crane hoist drum shaft assembly, removal and installation.



MEC 38 10-227-15/278

1 Stop Nut	12 Drum shaft gear	23 Ball bearing	34 Drum
2 Cap screw	13 Key	24 Relief fitting	35 Oil seal
3 Cap screw	14 R.H. Pillow block	25 Lube fitting	36 Ball bearing
4 Tube assembly	15 Lube fitting	26 Retaining ring	37 Ball bearing
5 Copper gasket	16 Retaining ring	27 Retaining ring	38 Key
6 Connector	17 Ball bearing	28 Retaining ring	39 Center ring
7 Bolt connector	18 Spacer	29 Retaining ring	40 Shaft
8 Connector	19 R.H. clutch	30 L.H. Pillow block	41 Dowel pin
9 Copper gasket	20 Drum	31 Ball bearing	
10 Rotating joint	21 Oil seal	32 Spacer	
11 Retaining ring	22 Ball bearing	33 L.H. clutch	

Figure 278. Crane hoist drum shaft assembly.

(5) Remove the hoist drum shaft assembly as instructed in figure 277.

*b. Disassembly.* Disassemble the hoist drum shaft assembly in numerical sequence as illustrated on figure 278.

#### 591. Crane Hoist Drum Shaft Assembly Cleaning, Inspection, and Repair

*a. Cleaning.* Clean all parts with an approved cleaning solvent and dry thoroughly.

*b. Inspection and Repair.* Inspect all parts for excessive wear or damage. Replace or repair worn or damaged parts.

#### 592. Crane Hoist Drum Shaft Assembly Reassembly and Installation

*a. Reassembly.* Reassemble the crane hoist drum shaft assembly in the reverse of the numerical sequence as illustrated on figure 278.

*b. Installation.* (1) Install the hoist drum shaft assembly as illustrated on figure 277.

AGO 6819A

- (2) Install the brake band assemblies (para. 192).
- (3) Install the gear and chain guards (para. 197).

- (4) Install the primary drive chain case cover (para. 196).
- (5) Install the crane cab assembly (para. 296).

## Section LXXV. CRANE COUNTERSHAFT ASSEMBLY

### 593. General

The countershaft assembly is located below the hoist drum shaft assembly and is secured by two bearings which are bolted to the same part of the revolving frame as the hoist drum shaft. The countershaft is the means for transmitting power from the crane engine to other shaft assemblies.

### 594. Crane Countershaft Assembly Removal and Disassembly

#### a. Removal.

- (1) Remove the crane cab assembly (para. 296).
- (2) Remove the primary drive chain case cover and drive chain (para. 196).
- (3) Remove the countershaft assembly as instructed on figure 279.

b. *Disassembly.* Disassemble the countershaft in numerical sequence as illustrated on figure 280.

### 595. Countershaft Assembly Cleaning, Inspection, and Repair

- a. *Cleaning.* Clean all parts with an approved cleaning solvent and dry thoroughly.
- b. *Inspection and Repair.* Inspect all parts for excessive wear or damage. Replace or repair all defective parts.

### 596. Crane Countershaft Assembly Reassembly and Installation

a. *Reassembly.* Reassemble the countershaft assembly in the reverse of the numerical sequence as illustrated on figure 280.

#### b. Installation.

- (1) Install the primary drive chain case cover and drive chain (para. 196).
- (2) Install main drive chain and chain guard (para. 196).
- (3) Install crane cab assembly (para. 296).

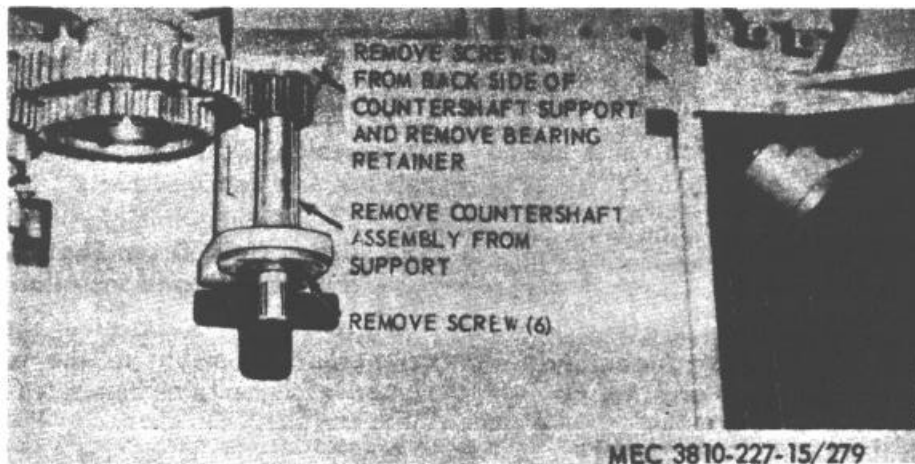
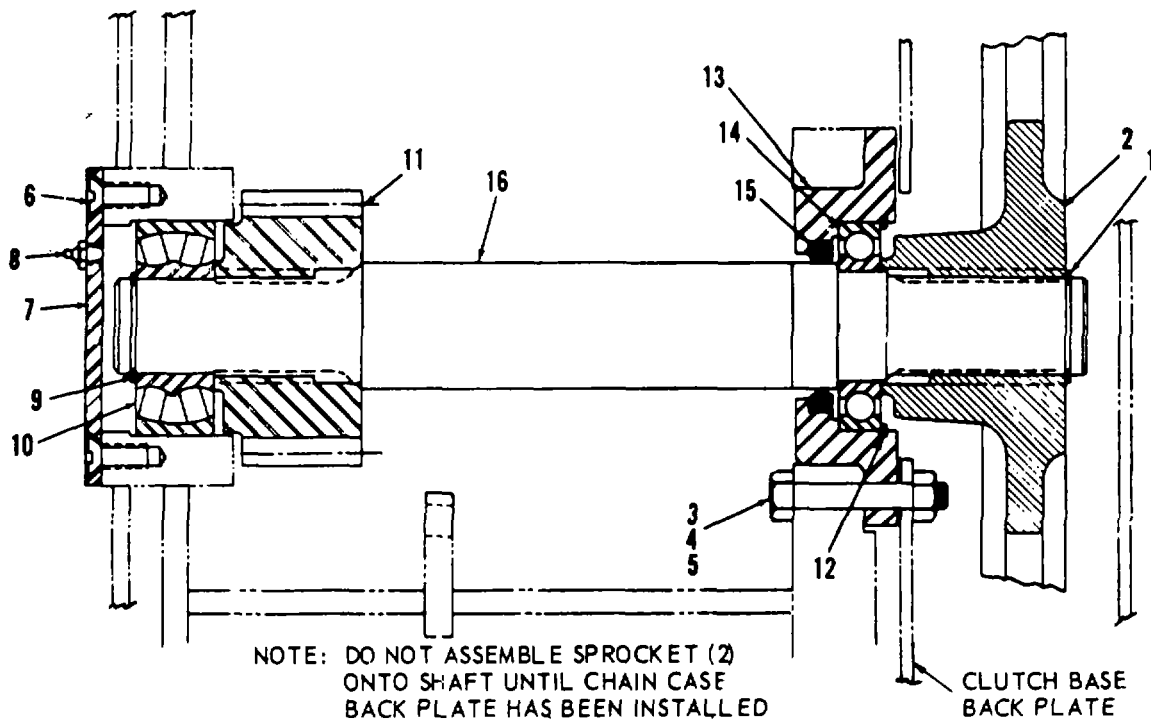

Figure 279. Crane countershaft assembly, removal and installation



MEC 3810-227-15/280

- |                     |                |                   |             |
|---------------------|----------------|-------------------|-------------|
| 1 Ring, retaining   | 5 Washer       | 9 Retaining ring  | 13 Insert   |
| 2 Sprocket          | 6 Cap screw    | 10 Bearing        | 14 Bearing  |
| 3 Cap screw, hex hd | 7 End plate    | 11 Spur pinion    | 15 Oil seal |
| 4 Nut               | 8 Lube fitting | 12 Retaining ring | 16 Shaft    |

Figure 280. Crane countershaft assembly.

**Section LXXVI. CRANE INDEPENDENT BOOM HOIST SHAFT ASSEMBLY**

**597. General**

The independent boom hoist shaft assembly consists of the boom hoist clutch, clutch drum, brakedrum, boom hoist drive chain sprocket, and the boom hoist gear. The shaft mounts to the revolving frame with two bearing unit.

**598. Crane Independent Boom Hoist Shaft Assembly Removal and Disassembly**

*a. Removal*

- (1) Remove the crane cab assembly (para. 296).
- (2) Remove the primary drive chain case and drive chain (para. 196).
- (3) Remove the boom hoist drive chain guard (para. 197).

- (4) Remove the shifting levers from the shifter collar, at the boom hoist clutch (para. 186).
- (5) Remove the boom hoist shaft assembly as instructed on figure 281.

*b. Disassembly.*

Disassemble the independent boom hoist shaft assembly in numerical sequence as illustrated on figure 282.

**599. Crane Independent Boom Hoist Shaft Assembly Cleaning, Inspection, and Repair**

- a. Cleaning.* Clean all parts with an approved cleaning solvent and dry thoroughly.
- b. Inspection and Repair.* Inspect all parts for excessive wear or damage. Replace or repair all defective parts.

AGO 6819A



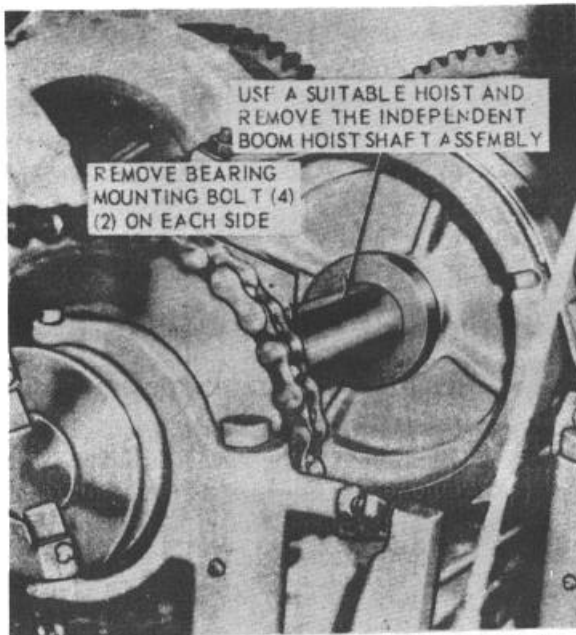

MEC 3810-227-15/281

Figure 281. Crane independent boom hoist shaft assembly, removal and installation.

**600. Crane Independent Boom Hoist Shaft Assembly, Reassembly and Installation**

a. *Reassembly.* Reassemble the boom hoist shaft assembly in the reverse of the numerical sequence as illustrated on figure 282.

b. *Installation.*

- (1) Install the boom hoist shaft as instructed on figure 281.
- (2) Install the shifting levers on the shifter collar of the boom hoist clutch (para. 186).
- (3) Install the boom hoist drive chain guard (para. 197).
- (4) Install the primary drive chain case cover and drive chain (para. 196).
- (5) Install the crane cab assembly (para. 296).

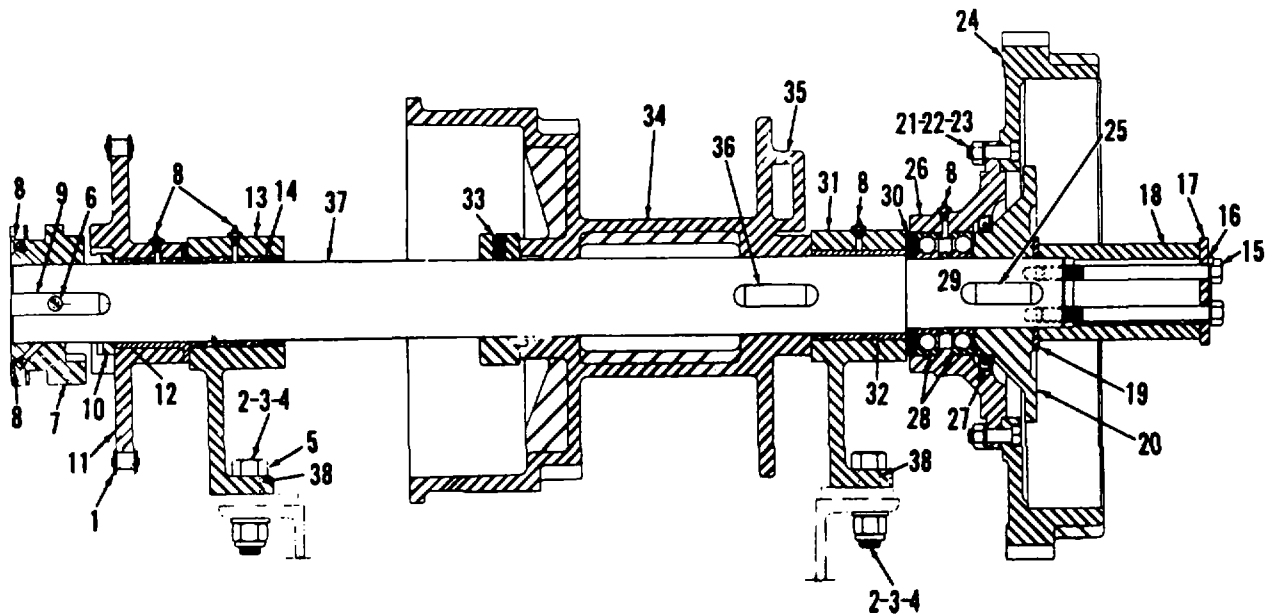

MEC 3810-227-15/282

Figure 282. Crane independent hoist shaft assembly.

1 Chain, Roller	11 Sprocket	21 Nut, F	31 Pillow block
2 Nut, self-locking	12 Bushing	22 Washer, lock	32 Bushing
3 Washer, flat	13 Pillow block	23 Cap screw, hex hd	33 Collar, plain
4 Cap screw, hex hd	14 Bushing	24 Gear & clutch flange	34 Drum
5 Special bolt	15 Cap screw, hex hd	25 Key	36 Wedge
6 Cap screw, flat Hd	16 Clip	26 Bearing housing	36 Key
7 Clutch jaw	17 End cap	27 Oil seal	37 Shaft
8 Fitting, lube	18 Sleeve	28 Bearing, ball	38 Dowel pin
9 Key	19 Spacer	29 Spacer	
10 Retaining ring	20 Clutch Ay. R.H.	30 Spacer	

Figure 282. - Continued.

## Section LXXVII. CRANE HORIZONTAL REVERSING SHAFT ASSEMBLY

### 601. General

The crane horizontal reversing shaft assembly is attached to the revolving frame below and to the rear of the hoist drum shaft assembly. This shaft has two beveled swing gears which drive the vertical reversing shaft assembly in either direction.

### 602. Crane Horizontal Reversing Shaft Assembly Removal and Disassembly

#### a. Removal.

- (1) Remove the crane cab assembly and the hoist drum shaft (paras 296 and 590).

- (2) Remove the countershaft assembly (para. 694).
- (3) Remove shifter lever shaft and remove shifter levers free of shifter collars on horizontal reversing shaft clutches (paras. 187 and 188).
- (4) Remove horizontal reversing shaft assembly as instructed on figure 283.

- #### b. Disassembly.
- Disassemble the horizontal reversing shaft assembly in numerical sequence as illustrated on figure 284.

### 603. Crane Horizontal Reversing Shaft Assembly Cleaning, Inspection, and Repair

a. *Cleaning.* Clean all parts in an approved cleaning solvent and dry thoroughly.

b. *Inspection and Repair.* Inspect all parts for excessive wear or damage. Replace or repair all defective parts.

### 604. Crane Horizontal Reversing Shaft Assembly, Reassembly and Installation

a. *Reassembly.* Reassemble the horizontal reversing shaft assembly in the reverse of the numerical sequence as illustrated on figure 284.

b. *Installation.*

- (1) Install the horizontal reversing shaft as assembly as instructed on figure 283.
- (2) Install shifter levers on shifter collars of horizontal reversing shaft clutches (paras. 187 and 188).
- (3) Install countershaft assembly (para. 596).
- (4) Install crane cab assembly and the hoist drum shaft (paras. 296 and 592).

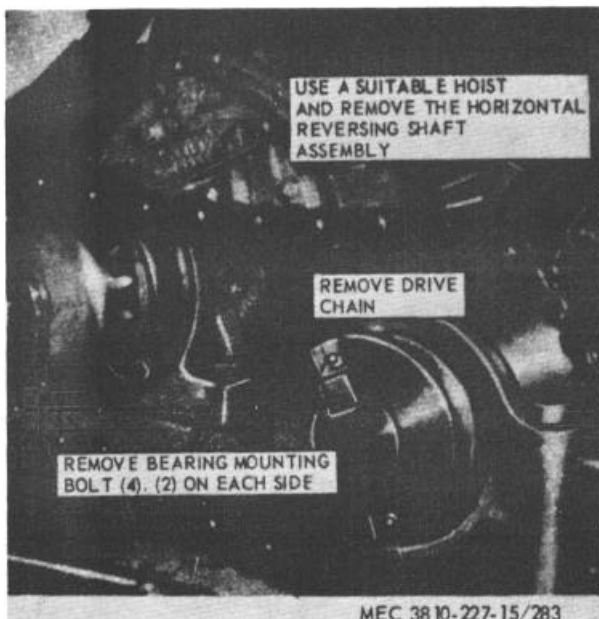
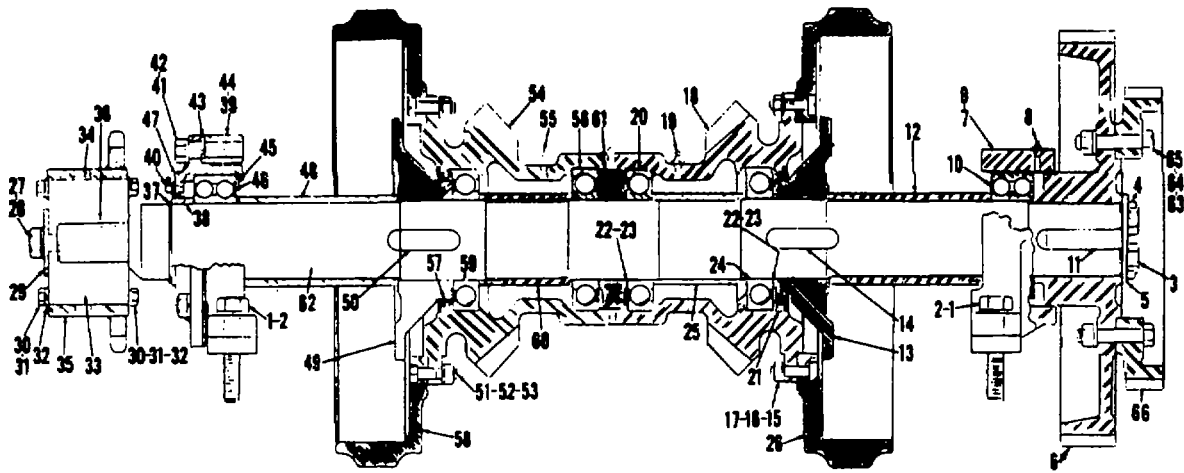

Figure 283. Crane horizontal reversing shaft assembly, removal and installation.



MEC 3810-227-15/284

- |                      |                      |                      |                      |
|----------------------|----------------------|----------------------|----------------------|
| 1 Cap screw, hex hd  | 18 Bevel gear        | 35 Clutch Housing    | 52 Washer, lock      |
| 2 Washer, lock       | 19 Fitting, lube     | 36 Key, sq both ends | 53 Cap screw, hex hd |
| 3 Cap screw, hex hd  | 20 Bearing           | 37 Ring, retaining   | 54 Bevel gear        |
| 4 Locking clip       | 21 Seal, oil         | 38 Spacer            | 55 Fitting, lube     |
| 5 End plate          | 22 Shim              | 39 Pillow block, LH  | 56 Bearing           |
| 6 Gear               | 23 Shim              | 40 Fitting, lube     | 57 Seal, oil         |
| 7 Pillow block R.H.  | 24 Bearing           | 41 Cap screw, hex hd | 58 Clutch flange     |
| 8 Fitting, lube      | 25 Spacer            | 42 Washer, lock      | 59 Bearing           |
| 9 Pin, dowel         | 26 Clutch flange     | 43 Shim              | 60 Spacer            |
| 10 Bearing           | 27 Cap screw, hex hd | 44 Pin, dowel        | 61 Center ring       |
| 11 Key, rd one end   | 28 Washer, lock      | 45 Ring, retaining   | 62 Shaft             |
| 12 Spacer, tubing    | 29 End cap           | 46 Bearing           | 63 Nut, F            |
| 13 Clutch ay.        | 30 Cap screw, hex hd | 47 Retainer, bearing | 64 Washer, lock      |
| 14 Key, sq both ends | 31 Washer, lock      | 48 Spacer, tubing    | 65 Cap screw, hex hd |
| 15 Nut, F            | 32 Retaining ring    | 49 Clutch assembly   | 66 Gear              |
| 16 Washer, lock      | 33 Clutch            | 50 Key, sq both ends |                      |
| 17 Capscrew, hex hd  | 34 Key, sq both ends | 51 Nut, F            |                      |

Figure 284. Crate horizontal reversing shaft assembly.

### Section LXXVII. CRANE VERTICAL REVERSING SHAFT ASSEMBLY

#### 605. General

The crane vertical reversing shaft assembly is driven by the horizontal reversing shaft assembly through beveled gears. A machined gear on the vertical reversing shaft meshes with a gear on the vertical swing shaft

assembly as instructed on figure 285.

b. Disassembly. Disassemble the vertical reversing shaft assembly in numerical sequence as shown on figure 285.

#### 606. Crane Vertical Reversing Shaft Assembly Removal and Disassembly

##### a. Removal.

- (1) Remove the crane cab assembly and the hoist drum shaft (paras. 296 and 590).
- (2) Remove the horizontal reversing shaft assembly (para. 602).
- (3) Remove the vertical reversing shaft

#### 607. Crane Vertical Reversing Shaft Assembly Cleaning, Inspection, and Repair

a. *Cleaning.* Clean all parts in an approved cleaning solvent and dry thoroughly.

b. *Inspection and Repair.* Inspect all parts for excessive wear or damage. Replace or repair defective parts.

AGO 6819A

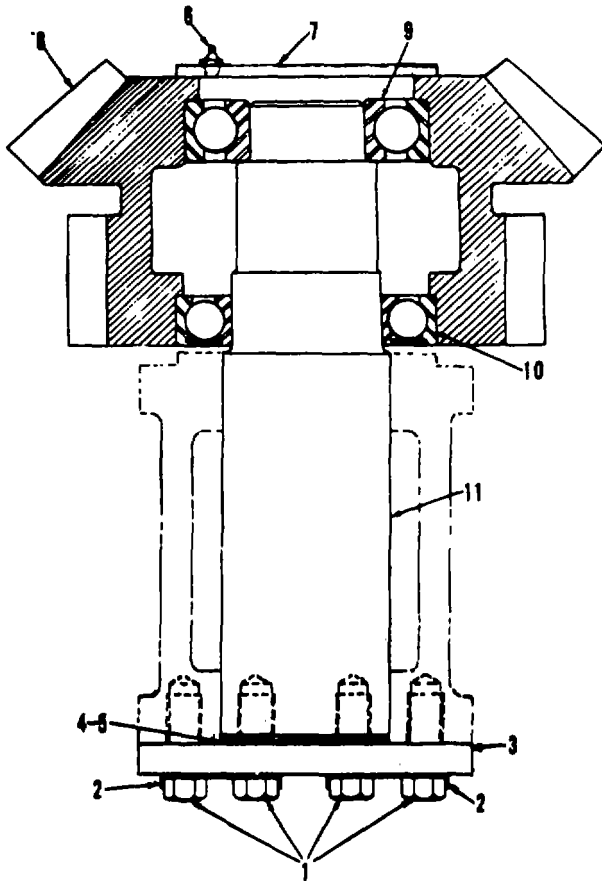

MEC 3810-227-15/285

- |                     |             |
|---------------------|-------------|
| 1 Cap screw, hex hd | 7 Pipe plug |
| 2 Plate, lock       | 8 Gear      |
| 3 Plate, End        | 9 Bearing   |
| 4 Shim              | 10 Bearing  |
| 5 Shim              | 11 Shaft    |
| 6 Fitting, lube     |             |

Figure 285. Crane vertical reversing shaft assembly, removal, disassembly, reassembly, and installation

### Section LXXIX. CRANE VERTICAL SWING SHAFT ASSEMBLY

#### 609. General

The crane vertical swing shaft assembly is driven by vertical reversing shaft through a set of gears. A machined gear on the bottom end of the vertical swing shaft meshes with the turn table gear on the carrier and provides a means of rotating the crane revolving frame to the desired position.

#### 608. Crane Vertical Reversing Shaft Assembly Reassembly and Installation

a. *Reassembly.* Reassemble the vertical reversing shaft in reverse of the numerical sequence shown on figure 285.

b. *Installation.*

- (1) Install the vertical reversing shaft assembly as instructed on figure 285.
- (2) Install the horizontal reversing shaft assembly (para. 604).
- (3) Install the hoist drum shaft and cab assembly (paras. 592 and 296).

#### 610. Crane Vertical Swing Shaft Assembly Removal and Disassembly

a. *Removal.*

- (1) Remove the crane cab assembly and the hoist drum shaft (paras. 296 and 590).
- (2) Remove the horizontal reversing shaft assembly (para. 602).

AGO 6819A

- (3) Remove the vertical reversing shaft assembly (para. 606).
- (4) Remove the vertical swing shaft assembly as instructed on figure 286.

b. *Disassembly.* Disassemble the vertical reversing shaft assembly in numerical sequence as shown on figure 287.

#### 611. Crane Vertical Swing Shaft Assembly Cleaning, Inspection, and Repair

a. *Cleaning.* Clean all parts with an approved cleaning solvent and dry thoroughly.

b. *Inspection and Repair.* Inspect all parts for excessive wear or damage. Replace or repair all defective parts.

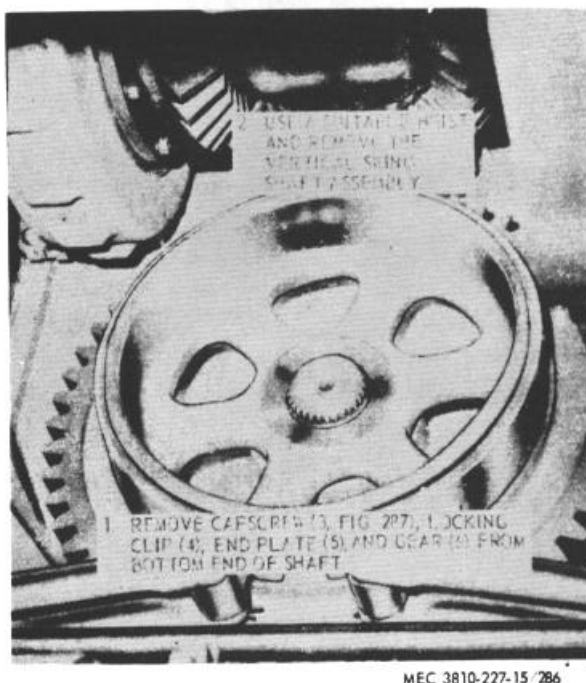
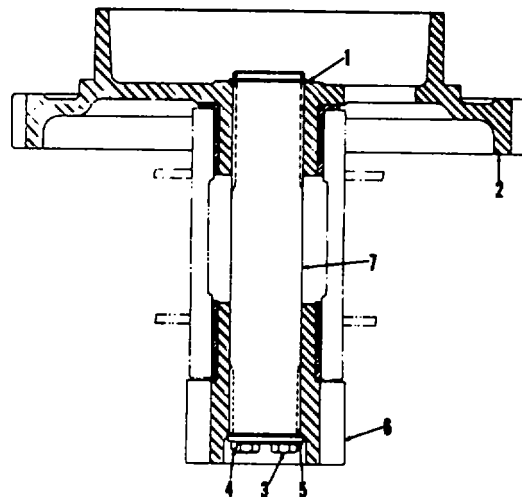

Figure 286. Crane vertical swing shaft assembly, removal and installation.



MEC 3810-227-15/287

Figure 287. Crane vertical swing shaft assembly.

#### 612. Crane Vertical Swing Shaft Assembly Reassembly and Installation

a. *Reassembly.* Reassemble the vertical swing shaft assembly in reverse of the numerical sequence shown on figure 287.

b. *Installation.*

- (1) Install the vertical swing shaft assembly as instructed on figure 286.
- (2) Install the vertical reversing shaft assembly (para. 608).
- (3) Install the horizontal reversing shaft assembly (para. 604).
- (4) Install the hoist drum shaft and crane cab assembly (paras. 592 and 296).

### Section LXXX. CRANE AUXILIARY SHAFT ASSEMBLY (POWER LOAD LOWERING)

#### 613. General

The crane auxiliary shaft assembly is used for power load lowering to power-down a load under power at a speed controlled by the engine throttle setting. The auxiliary shaft assembly is gear driven and mounts to the revolving frame with two bearings.

#### 614. Crane Auxiliary Shaft Assembly Removal and Disassembly

a. *Removal.*

- (1) Remove the crane cab assembly and hoist drum shaft (paras. 296 and 590).

AGO 6819A

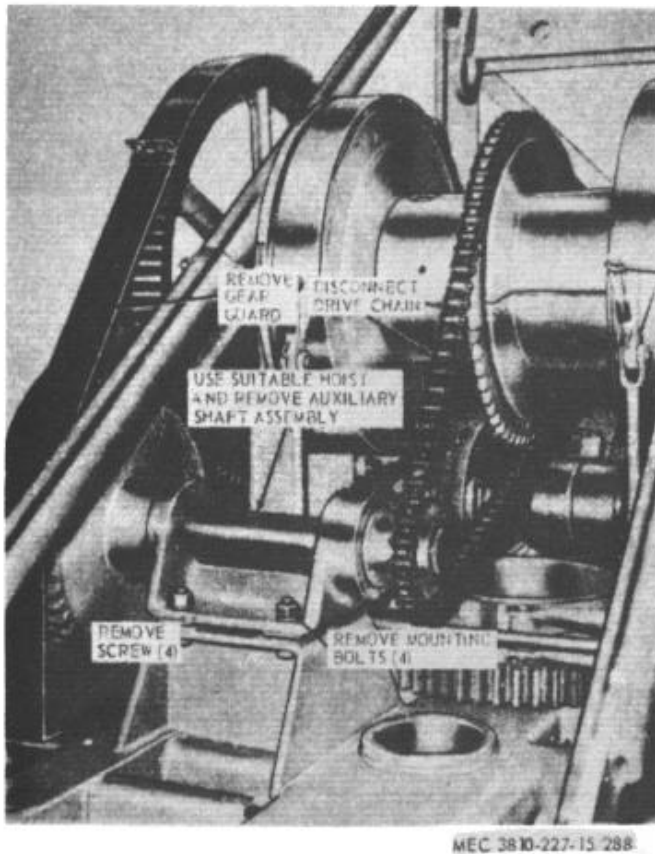

**Figure 288. Crane auxiliary shaft assembly, removal and installation.**

(2) Remove the auxiliary shaft assembly as instructed on figure 288.

*b. Disassembly.* Disassemble the auxiliary shaft assembly in the numerical sequence shown on figure 289.

#### **615. Crane Auxiliary Shaft Assembly Cleaning, Inspection and Repair**

*a. Cleaning.* Clean all parts with an approved cleaning solvent and dry thoroughly.

*b. Inspection and Repair.* Inspect all parts for excessive wear and damage. Replace or repair damaged or defective parts.

#### **616. Crane Auxiliary Shaft Assembly Reassembly and Installation**

*a. Reassembly.* Reassemble the crane auxiliary shaft assembly in reverse of the numerical sequence shown on figure 289.

*b. Installation.*

(1) Install the crane auxiliary shaft as instructed on figure 288.

(2) Install the hoist drum shaft assembly and crane cab assembly (paras. 592 and 296).

### **Section LXXXI. CRANE ROTATING FRAME BASE ASSEMBLY**

#### **617. General**

The crane rotating main frame base supports the entire crane assembly that includes the deck machinery, operator's cab, engine and crane boom. It is made up of structural iron weldments. Rotation is by means of rollers attached to the main frame base, operating around a ring gear and center pin mounted on the carrier.

#### **618. Crane Rotating Frame Base Assembly Removal**

- a. Remove the crane boom assembly (para. 204).
- b. Remove the front and rear roller assemblies (para. 199 and 200).
- c. Remove the crane cab assembly (para. 296).
- d. Remove the operator's controls.

- e. Disconnect and remove all lines and wiring.
- f. Remove the crane engine (para. 297).
- g. Remove the rear gantry legs (para. 626).
- h. Remove the fuel tank (para. 308).
- i. Remove the lights and reflectors.
- j. Remove the hoist drum shaft assembly (para. 590).
- k. Remove the countershaft assembly (para. 594).
- l. Remove the independent boom hoist shaft assembly (para. 598)
- m. Remove the horizontal reversing shaft assembly (para. 602).
- n. Remove the vertical reversing shaft assembly (para. 606).
- o. Remove the vertical swing shaft assembly (para. 610).

AGO 6819A

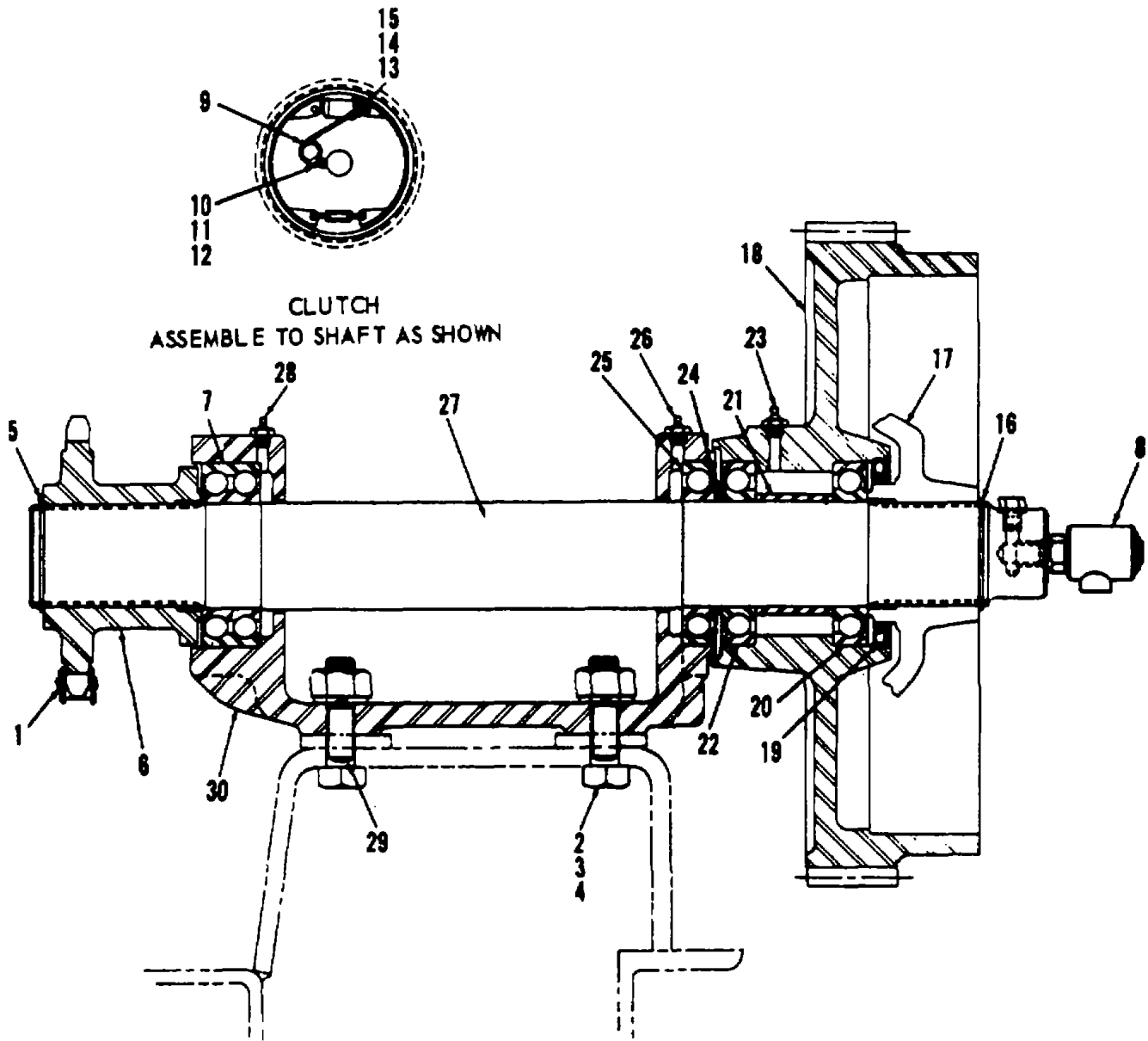

MEC 3810-227-15/289

- |                     |                         |                  |
|---------------------|-------------------------|------------------|
| 1 Chain, roller     | 11 Gasket               | 21 Spacer        |
| 2 Nut, F            | 12 Nut, tube            | 22 Bearing       |
| 3 Washer, lock      | 13 Connector bolt       | 23 Fitting, lube |
| 4 Cap screw, hex hd | 14 Connector            | 24 Spacer        |
| 5 Ring, retaining   | 15 Gasket               | 25 Bearing       |
| 6 Sprocket          | 16 Ring, retaining      | 26 Fitting, lube |
| 7 Bearing           | 17 Clutch Ay            | 27 Shaft         |
| 8 Joint, rotating   | 18 Gear & clutch flange | 28 Fitting, lube |
| 9 Tubing, copper    | 19 Seal, oil            | 29 Pin, dowel    |
| 10 Connector        | 20 Bearing              | 30 Housing       |

Figure 289. Crane auxiliary shaft assembly.

AGO 6819A

p. Remove the auxiliary shaft assembly (para. 614).

#### 619. Crane Rotating Frame Base Assembly Cleaning, Inspection, and Repair

a. *Cleaning.* Clean the crane rotating frame base with live steam.

b. *Inspection and Repair.* Inspect the crane rotating frame base for excessive wear or damage. Replace or repair a damaged or defective rotating frame base assembly.

#### 620. Crane Rotating Frame Base Assembly Installation

- a. Install the auxiliary shaft assembly (para. 616).
- b. Install the vertical swing shaft assembly (para. 612).
- c. Install the vertical reversing shaft assembly (para. 608).

d. Install the horizontal reversing shaft assembly (para. 604).

e. Install the independent boom hoist shaft assembly (para. 600).

f. Install the countershaft assembly (para. 596).

g. Install the hoist drum shaft assembly (para. 592).

h. Install lights and reflectors.

i. Install fuel tank (para. 310).

i. Install the rear gantry legs (para. 628).

k. Install the crane engine (para. 297).

l. Install and connect all lines and wiring.

m. Install the operator's controls.

n. Install the crane cab assembly (para. 296).

o. Install the front and rear roller assemblies (para. 199 and 200).

p. Install the crane boom assembly (para. 204).

### Section LXXXII. ROTATING FRAME RING GEAR

#### 621. General

A dual flanged center, hub-type ring gear, is bolted to the carrier frame and serves as the swing or tracking gear in which the crane assembly rotating gear and rollers operate.

#### 622. Rotating Frame Ring Gear Removal

- a. Remove the crane boom assembly (para. 204).
- b. Remove the crane rotating frame base assembly (para. 618).
- c. Remove the rotating frame ring gear as instructed on figure 290.

#### 623. Rotating Frame Ring Gear Cleaning, Inspection and Repair

a. *Cleaning.* Clean all parts with an approved cleaning solvent and dry thoroughly.

b. *Inspection and Repair.* Inspect all parts for excessive wear and damage. Replace or repair all defective parts.

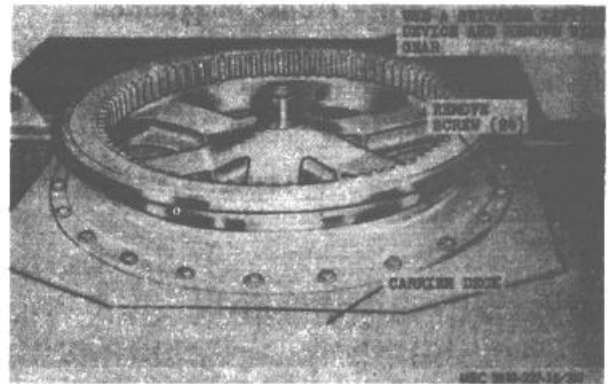

Figure 290. Rotating frame ring gear, removal and installation.

#### 624. Rotating Frame Ring Gear Installation

a. Install the rotating frame ring gear assembly as illustrated on figure 290.

b. Install the crane rotating frame base assembly (para. 620).

c. Install the crane boom assembly (para. 204).



## Section LXXXIII. CRANE GANTRY FRAME

### 625. General

The crane gantry frame is a supporting device used to support the boom. It is mounted on the crane frame by means of pins and is constructed of heavy steel.

### 626. Crane Gantry Frame Removal

- a. Remove the crane gantry sheave block.
- b. Remove the crane cab assembly (para. 296).
- c. Remove the crane gantry frame from the revolving frame as instructed on figure 291.

### 627. Crane Gantry Frame Cleaning, Inspection and Repair

- a. *Cleaning.* Clean the crane gantry frame with an approved cleaning solvent.
- b. *Inspection and Repair.* Inspect the crane gantry frame and pins for cracks, breaks, bends, and excessive wear. Replace or repair defective crane gantry frame or pins as necessary. Replace cotter pins.

### 628. Crane Gantry Frame Installation

- a. Install the crane gantry frame on the revolving frame as illustrated on figure 291.
- b. Install the crane cab assembly (para. 296).
- c. Install the crane gantry sheave block.

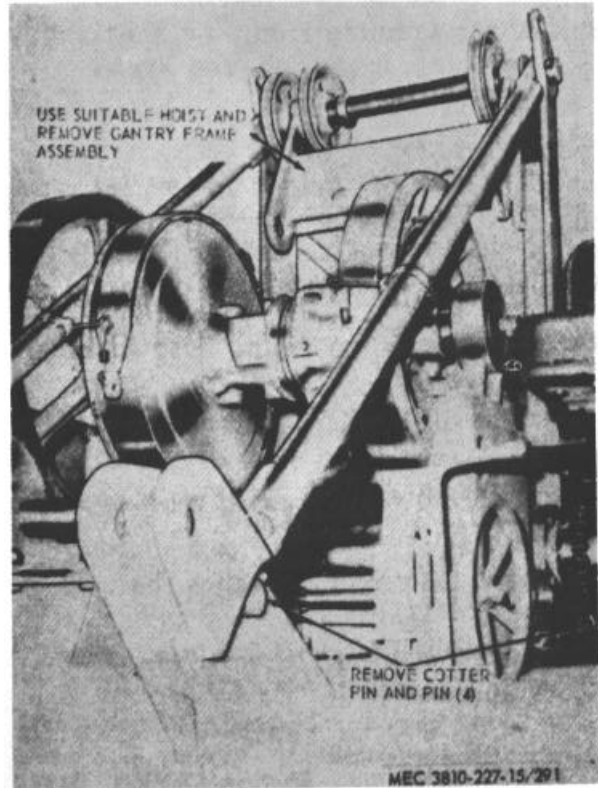

Figure 291. Crane gantry frame, removal and installation.

## CHAPTER 5

### DEMOLITION, SHIPMENT AND LIMITED STORAGE

---

#### Section I. DEMOLITION OF THE CRANE TO PREVENT ENEMY USE

##### 629. General

When capture or abandonment of the crane to an enemy is imminent, the responsible unit commander must make the decision either to destroy the equipment or to render it inoperative. Based on this decision, orders are issued which cover the desired extent of destruction. Whatever method of demolition is employed, it is essential to destroy the same vital parts of all cranes and all corresponding repair parts.

##### 630. Demolition to Render The Equipment Inoperative

*a. Demolition by Mechanical Means.* Use sledge hammers, crowbars, picks, axes, or any other heavy tools which may be available to destroy the following:

- (1) Engine block and manifold.
- (2) Carburetor, distributor, governor, and water pump.
- (3) Radiator, starter, and generator.

##### Note

**The above procedures are minimum requirements for this method.**

- (4) Cables, drum brakes, clutches, control levers, and rollers.
- (5) Carrier transmission, transfer case, and differentials.

*b. Demolition by Misuse.* Perform the following steps to render the engine inoperative.

- (1) Drain the engine radiators and crankcases.
- (2) Throw sand and other abrasive material into the engine clutches, main drive chain cases, jack shafts, bevel gears, horizontal gear trains, hydraulic steering reservoirs, and all other accessible gear cases.

##### Note

**The above procedures are minimum requirements for this method.**

- (3) Start both engines and engage the crane master clutch.
- (4) Operate the unit until failure occurs.

##### 631. Demolition by Explosives or Weapon's Fire

*a. Explosives.* Place as many of the following charges (fig. 292) as the situation permits and detonate them simultaneously with a detonating cord and a suitable detonator.

##### (1) *Revolving frame machine.*

- (a) One ½-pound charge on each horizontal reversing shaft clutch.
- (b) Two ½-pound charges on the boom hoist clutch.
- (c) One ½-pound charge on each drum clutch.
- (d) Two ½-pound charges on the engine block.
- (e) One ½-pound charge on power load lowering clutch.

##### (2) *Carrier.*

- (a) One ½-pound charge on front differential.
- (b) One ½-pound charge on engine block.
- (c) One ½-pound charge on transmission.
- (d) One ½-pound charge between the right rear and left front of dual tires.
- (e) One ½-pound charge on left front wheel hub.

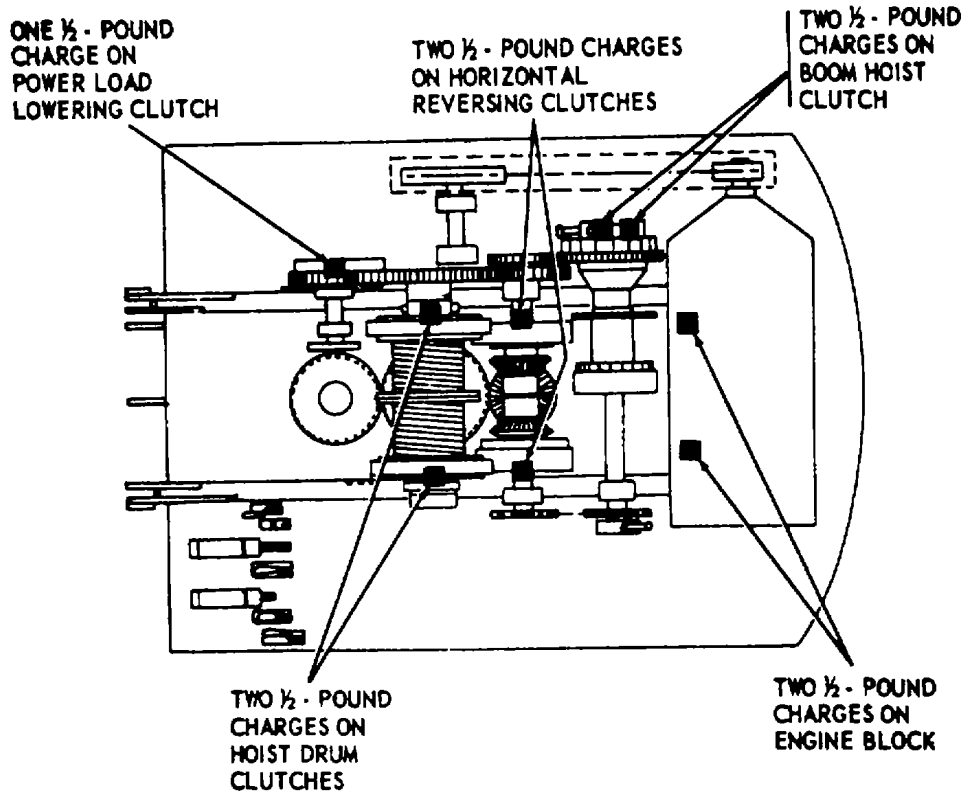

A - Placement of charges on revolving frame

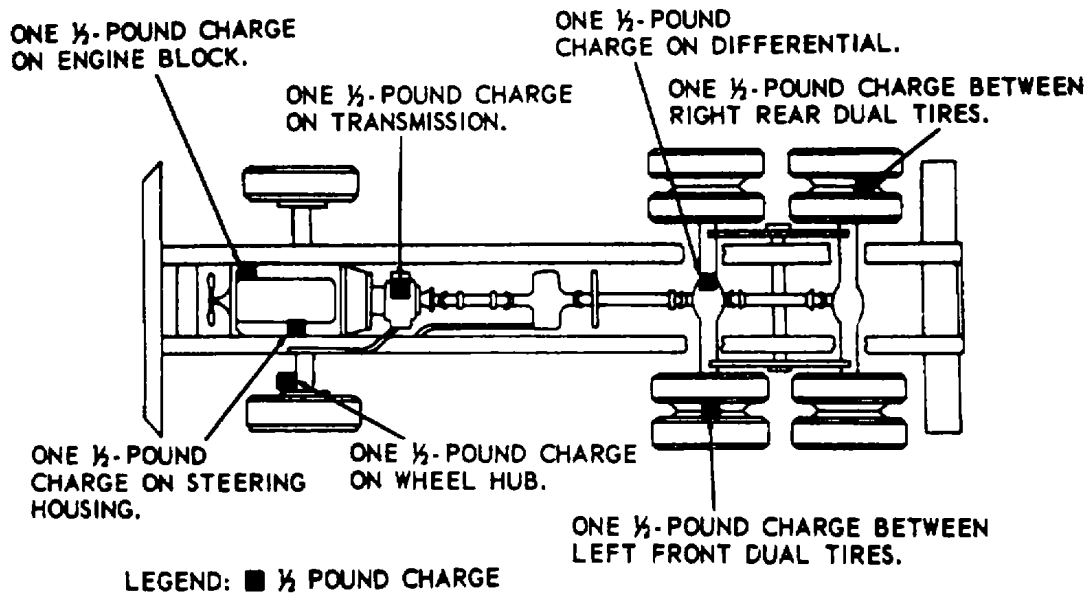

B - Placement of charges on carrier

MEC 3810-227-15/292

Figure 292. Placement of charges.

- (f) One ½-pound charge on steering gear housing.

*b. Weapon's Fire.* Fire on crane, carrier, and attachments with the heaviest practical weapons available. If possible, aim for the engine block from either side.

### 632. Other Demolition Methods

*a. Scattering and Concealment.* Remove all easily accessible vital parts such as batteries, oil filters, generator, generator regulator, distributor, starter, carburetors, and filters. Scatter them throughout the underbrush or dense foliage, bury them in dirt or sand, or throw them in a lake, stream, well, or other body of water.

*b. Burning.* Pack rags, clothing, canvas, or brush inside, and around the crane unit. Saturate this packing with gasoline, oil, or diesel fuel and ignite.

## Section II. SHIPMENT AND LIMITED STORAGE

### 634. Preparation of Equipment For Shipment

*a. General.* Detailed instructions for the preparation of the crane-shovel for domestic shipment are outlined within this paragraph. Preservation will be accomplished in sequence that will not require the operation of previously preserved components.

*b. Inspection.* The crane-shovel will be inspected for any unusual conditions such as damage, rusting, accumulation of water, and pilferage. DA Form 2404 (Work sheet for Preventive Maintenance and Technical Inspection of Engineer Equipment) will be executed on the equipment.

*c. Cleaning and Drying.* Thorough cleaning and drying by an approved technique is the first essential procedure in any effective preservation process. Approved methods of cleaning and drying, types of preservatives, and methods of application are described in TM 38-230.

*d. Painting.* Paint all surfaces when the paint has been removed or damaged. Refer to TB ENG-60 for detailed cleaning and painting instruction.

*c. Submersion.* Totally submerge the crane and carrier in a deep body of water to provide water damage and concealment. Salt water will cause greater damage to metal parts than fresh water.

### 633. Training

All operators should receive thorough training in the destruction of the crane carrier, and attachments. Refer to FM 5-25. Simulated destruction, using all of the methods listed above, should be included in the operator training program. It must be emphasized in training, that demolition operations are usually necessitated by critical situations when time available for destruction is limited. For this reason, it is necessary that operators be thoroughly familiar with all methods of destruction of equipment and be able to carry out demolition instructions without reference to this or any other manual.

*e. Depreservation Guide.* DA Form 2258 (Depreservation Guide of Engineer Equipment.)

- (1) A properly annotated depreservation guide will be completed concurrently with preservation for each item of mechanical equipment with any peculiar requirements outlined in the remarks column. The complete depreservation guide will be placed with the cranes shovel in a water-proof envelope, marked "Depreservation Guide", and fastened in a conspicuous location on or near the operator's controls.
- (2) Prior to placing the crane-shovel in operation or to the extent necessary for inspection, depreservation of the item shall be performed as outlined on the Depreservation Guide.

*f. Cooling System.* Determine that cooling system is filled to the proper level with a clean solution of 50 percent water and 50 percent ethyleneglycol conforming to Specification A-548, type 1.

#### Note

**It is not necessary to drain and refill cooling system if the solution is clean and checks to a -25°F**

**If temperatures below -25°F are expected, antifreeze conforming to Specification MIL-C-11755 shall be used in its undiluted condition.**

*g. Lubrication Systems.* Check level of lubricant. Operate the engines at a fast idle until lubricant has been circulated throughout the system.

*h. Sealing of Openings.* Openings that will permit the direct entry of water into the interior of the gasoline engine-driven equipment, starting motor, etc., shall be sealed with pressure-sensitive tape conforming to Specification PPP-T-60, type III, Class 1.

*i. Fuel Tanks.* If the fuel tank is empty, it will be fogged with type P-10, grade 2 engine preservative oil conforming to MIL-L-21260. It is not required to drain the tank of operating fuels.

*j. Exterior Surfaces.* Coat exposed machined ferrous metal surfaces with preservative (P-6) conforming with Specification MIL-C-11796, class 3. If preservative is not available, cup grease may be used.

*k. Marking.* Shall conform to MIL-STD-129.

*l. Batteries and Cables.* Batteries shall be secured in the battery compartment. Battery shall be filled and fully charged. Cables shall be disconnected, ventholes sealed, and all terminals wrapped and secured with type III, class 1 pressure-sensitive tape conforming to Specification PPP-T-60.

*m. Pneumatic Tires.* Tires shall be inflated to their normal required operating pressure.

*n. Air Cleaners.* Drain the air cleaners and seal all openings that permit the direct entry of water.

*o. Disassembly, Disassembled Parts, Basic Issue Items.*

- (1) Disassembly shall be limited to the removal of parts and projecting components that tend to increase the overall profile of the equipment and that which is subject to pilferage.
- (2) Disassembled items shall be packed with the publications in the toolbox if possible. Otherwise, items will be packed in a

suitable container and secured to the equipment to prevent loss or pilferage.

### **635. Loading Equipment for Shipment**

*a.* Construct a ramp of suitable material as illustrated on figure 4 and back the crane-shovel on a flatcar or trailer. Block and secure the crane-shovel as illustrated on figure 4. If the crane-shovel is on a flatcar, cover red and amber lamps and reflectors with pressure sensitive tape conforming to Specification PPP-T-60, type III, class 1.

*b.* If a loading ramp or material is not available and a suitable lifting device is used, the equipment shall be loaded as follows:

- (1) Attach a cable sling into the lifting eyes.
- (2) Lift the crane shovel and center it on the flatcar.
- (3) Remove the cable sling from the lifting eyes. Block and secure the crane shovel to the flatcar as illustrated on figure 4.

### **636. Preparation of Equipment for Storage**

*a. General.* Detailed instructions for preservation and maintaining equipment in limited storage are outlined in this paragraph. Limited storage is defined as storage not to exceed 6 months. Refer to AR 743-505.

*b. Inspection.* Refer to paragraph 634.

*c. Cleaning and Drying.* Refer to paragraph 634.

*d. Painting.* Refer to paragraph 634.

*e. Depreservation Guide.* Refer to paragraph 634.

*f. Cooling System.* Refer to paragraph 634.

*g. Lubrication.* Refer to paragraph 634.

*h. Sealing of Openings.* Refer to paragraph 634.

*i. Fuel Tanks.* Tanks will be drained and sprayed or fogged with type P-10, grade 2 engine preservative oil, MIL-L-21260.

*j. Exterior Surfaces.* Refer to paragraph 634.

AGO 6819A

k. *Batteries and Cables.* Refer to paragraph 634.

l. *Pneumatic Tires.* Pneumatic tires standing in storage under load will be inflated to the proper pressure. When the equipment is blocked and all weight is removed from the tires, deflate tires to two-thirds normal tire pressure.

m. *Disassembly, Disassembled Parts, Basic Issue Items.* Refer to paragraph 634.

n. *Weatherproofing.* When suitable shelter is not available, select a firm level, well-drained storage location, protected from prevailing winds. Position the crane-shovel on heavy planking or other solid surfaces. Block the equipment in a manner to remove all weight from tires. Cover the crane-shovel with a tarpaulin or

other suitable waterproof covering and tie down securely.

**637. Inspection and Maintenance of Equipment in Storage**

a. *Exercising.* Every 90 days equipment will be inspected as outlined in paragraph 39 and operated long enough to bring it up to its operating temperature for complete lubrication of gears, bearings, etc. After each exercising period the equipment will be represerved.

b. *Represervation.* At completion of inspection and exercising, the crane-shovel will be represerved to meet the requirements of paragraph 634.

## APPENDIX I

### REFERENCES

---

#### 1. Dictionaries of Terms and Abbreviations

AR 320-5 Dictionary of United States Army Terms  
AR 320-50 Authorized Abbreviations and Brevity Codes

#### 2. Fire Protection

SB 5-111 Supply of DA approved Fire Extinguishers to Army Troop Users  
TM 5-687 Repair and Utilities Fire Protection Equipment and Appliances: Inspections, Operations, and Preventive Maintenance  
TM 9-1799 Ordnance Maintenance, Fire Extinguisher

#### 3. Lubrication

LO 5-3810-227-15 Crane-Shovel, Basic Unit, Truck Mounted: 20 Ton  $\frac{3}{4}$  Cu Yd; Gasoline Engine, 6x6 (American Hoist and Derrick Models) Model W-2860 (Winterized) and 2360 (Non-Winterized) (W/Continental Engine Models) Model SS749 (Carrier) BS415 (Crane)

#### 4. Painting

TB ENG 60 Preservation and Painting of Serviceable Corps of Engineer Equipment

#### 5. Preventive Maintenance

AR 750-5 Organization, Policies and Responsibilities for Maintenance Operation  
TB ENG 347 Winterization Techniques for Engineer Equipment  
TM 5-764 Electric Motor and Generator Repair  
TM 9-207 Operation and Maintenance of Ordnance Materiel in Extreme Cold (0° to -65° F.)  
TM 9-214 Inspection, Care, and Maintenance of Anti-friction Bearings  
TM 9-6140-200-15 Storage Batteries, Lead-Acid Type  
TM 38-750 Army Equipment Record System and Procedures

#### 6. Publication Indexes

DA Pam 108-1 Index of Army Motion Pictures, Film Strips, and Phono-Recordings  
DA Pam 310-1 Index of Administrative Publications  
DA Pam 310-2 Index of Blank Forms  
DA Pam 310-3 Index of Training Publications  
DA Pam 310-4 Index of Technical Manuals, Technical Bulletins, Supply Bulletins, Lubrication Orders, and Modification Work Orders  
DA Pam 310-5 Index of Graphic Training Aids and Devices  
DA Pam 310-25 Index of Supply Manuals-Corps of Engineers

AGO 6819A

## **7. Radio Interference Suppression**

TM 11-483 Radio Interference Suppression

## **8. Shipment and Limited Storage**

AR 743-505 Limited Storage of Engineers Mechanical Equipment

TM 9-200 General Packaging Instructions for Ordnance General Supplies

TM 3-230 Preservation, Packaging, and Packing of Military Supplies and Equipment

## **9. Supply Publications**

C9100SL Petroleum, Petroleum-Base Products and Related material Organizational Maintenance Repair Parts and Special Tools List

TM 5-3810-227-20P Organizational Maintenance Repair Parts and Special Tool Lists. Crane-Shovel, Basic Unit, Truck Mounted: 20 Ton,  $\frac{3}{4}$  Cu Yd; Gasoline Engine, 6x6 (American Hoist and Derrick Models) Model 2360 (Non-Winterized) FSN 3810-989-0505 Model W2360 (Winterized) FSN 3810-989-0506.

TM 5-3810-227-35P Direct and General Support, and Depot Maintenance Repair Parts and Special Tool Lists. Crane-Shovel, Basic Unit, Truck Mounted: 20 Ton,  $\frac{3}{4}$  Cu Yd; Gasoline Engine, 6x6 (American Hoist and Derrick Models) Model 2360 (Non-Winterized) FSN 3810-989-0505 Model W2360 (Winterized) FSN 3810-989-0506

## **10. Training Aids**

FM 5-25 Explosives and Demolition

FM 21-5 Military Training

FM 21-6 Techniques of Military Instruction

FM 21-30 Military Symbols



## APPENDIX II

### MAINTENANCE ALLOCATION

---

#### Section I. INTRODUCTION

##### 1. General

This appendix contains explanations of all maintenance and repair functions authorized the various levels of maintenance. Section II contains the maintenance allocation chart.

##### 2. Maintenance

Maintenance is any action taken to keep materiel in a serviceable condition or to restore it to serviceability when it is unserviceable. Maintenance of materiel includes the following:

*a. Service.* To clean, preserve, and replenish fuel and lubricants.

*b. Adjust.* To regulate periodically to prevent malfunction.

*c. Inspect.* To verify serviceability and detect incipient electrical or mechanical failure by scrutiny.

*d. Test.* To verify serviceability and detect incipient electrical or mechanical failure by use of special equipment such as gages, meters, and the like.

*e. Replace.* To substitute serviceable assemblies, subassemblies, and parts for unserviceable components.

*f. Repair.* To restore an item to serviceable condition through correction of a specific failure or unserviceable condition. This function includes, but is not limited to, inspecting, cleaning, preserving, adjusting, replacing, welding, riveting, and straightening.

*g. Align.* To adjust two or more components of an electrical system so that their functions are properly synchronized.

*h. Calibrate.* To determine, check, or rectify the graduation of an instrument, weapon, or weapons system.

*i. Overhaul.* To restore an item to completely serviceable condition as prescribed by serviceability standard developed and published by heads of technical services. This is accomplished through employment of the technique of "Inspect and Repair Only as Necessary" (IROAN). Maximum utilization of diagnostic and test equipment is combined with minimum disassembly of the item during the overhaul process.

##### 3. Explanation of Columns

*a. Functional Group.* The functional group is a numerical group set up on a functional basis. The applicable Function Grouping Indexes (obtained from the United States Army Mobility Command) are listed on the MAC in the appropriate numerical sequences. These indexes are normally set up in accordance with their function and proximity to each other.

*b. Components and Related Operation.* This column contains the Functional Grouping Index heading, subgroup headings, and a brief description of the part starting with the noun name. It also designates the operations to be performed such as service, adjust, inspect, test, replace, repair, and overhaul.

*c. Levels of Maintenance.* This column contains the various levels of maintenance by letter designations:

O/C	-----	Operator or Crew
O	-----	Organizational
DS	-----	Direct Support
GS	-----	General Support
D	-----	Depot

An X placed in the appropriate level of maintenance column in line with and indicated maintenance function authorizes that level to perform the function. The X indicates the lowest

AGO 6819A

level of maintenance responsible for performing the function, but does not necessarily indicate repair parts stockage at that level. Higher levels of maintenance are authorized to perform the indicated functions of lower levels.

*d. Remarks.* This column lists specific maintenance functions, special tools, cross-references, instructions, and the like pertinent to the operation being performed.

**Section II. MAINTENANCE ALLOCATION CHART**

Functional group	Components and related operation	Levels of maintenance					Remarks
		O/C	O	DS	GS	D	
01	CRANE SECTION						
0100	ENGINE						
	Engine Assembly						
	Engine, Gasoline						
	Service -----	X					
	Inspect -----	X					
	Test -----		X				Compression
	Replace -----			X			
	Repair -----		X				
	Overhaul -----				X		
0101	Crankcase, Cylinder Head						
	Crankcase						
	Replace -----				X		
	Head, cylinder						
	Replace -----			X			
0102	Crankshaft						
	Crankshaft						
	Replace -----				X		
	Repair -----						
	Bearings -----						
	Replace -----				X		
	Crank jaw and pulley						
	Replace -----			X			
0103	Flywheel Assembly						
	Flywheel						
	Replace -----				X		
	Repair -----				X		
	Housing						
	Replace -----				X		
0104	Pistons, Connecting Rods						
	Pistons; rings; pins; retainers; bearing, rod						
	Replace -----				X		
	Rods, connecting						
	Replace -----				X		
	Repair -----				X		
0105	Valves, Camshafts and Timing System						
	Valves; seats, inserts						
	Replace -----			X			
	Repair -----			X			
	Springs; guides; locks; gears						
	Replace -----			X			
	Tappets						
	Adjust -----		X				
	Replace -----			X			

Functional group	Components and related operation	Levels of maintenance					Remarks
		O/C	O	DS	GS	D	
0106	Cover, valve						
	Replace -----	----	X				
	Camshaft; bushings						
	Replace -----	----	----	----	X		
	Engine Lubrication System						
	Pump, oil						
	Replace -----	----	----	X			
	Filter, oil						
	Service -----	X					
	Replace -----	----	X				
	Repair -----	----	X				
	Gage, level						
	Replace -----	X					
	Valve, relief; fittings; filler; hoses						
Replace -----	----	X					
Breather							
Service -----	X						
Replace -----	----	X					
Pan, oil							
Replace -----	----	----	X				
0108	Manifolds						
	Manifolds; pipe; valve, control; clamps						
	Replace -----	----	X				
02	CLUTCH ASSEMBLY						
0200	Clutch Assembly						
	Clutch Assembly						
	Service -----	X					
	Adjust -----	X					
	Replace -----	----	----	X			
	Repair -----	----	----	X			
0202	Clutch Release Mechanism						
	Yoke; shaft; throwout						
	Replace -----	----	----	X			
	Linkage and lever						
	Replace -----	----	X				
03	FUEL SYSTEM						
0301	Carburetor						
	Carburetor						
	Adjust -----	X					
	Replace -----	----	X				
	Repair -----	----	----	X			
0302	Fuel Pumps						
	Pump, fuel						
	Service -----	X					
	Replace -----	----	X				
	Bowl and gasket						
	Replace -----	----	X				
0304	Air Cleaner						
	Cleaner, Air						
	Service -----	X					
	Replace -----	----	X				
	Repair -----	----	X				
	Preheater; hose; clamps						
	Replace -----	----	X				

Functional group	Components and related operation	Levels of maintenance					Remarks
		O/C	O	DS	GS	D	
0306	Tanks, Lines, Fittings						
	Tank, fuel						
	Service -----	X					
	Replace -----	---	X				
	Cap, tank; strainer; fittings						
	Replace -----	---	X				
	Lines						
	Replace -----	---	X				
	Repair -----	---	X				
0308	Engine Speed Governor						
	Governor assembly						
	Replace -----	---	X				
	Repair -----	---	---	X			
	Link						
	Replace -----	---	X				
0312	Throttle or Choke Controls						
	Control, throttle						
	Service -----	X					
	Replace -----	---	X				
	Repair -----	---	X				
	Choke, control						
	Replace -----	---	X				
04	EXHAUST SYSTEM						
0401	Mufflers and Pipes						
	Muffler; pipe; guard; clamps						
	Replace -----	---	X				
05	COOLING SYSTEM						
0501	Radiator						
	Radiator						
	Service -----	X					
	Inspect -----	X					
	Replace -----	---	X				
	Cap						
	Replace -----	X					
0503	Thermostat and Housing, Gasket						
	Thermostat						
	Test -----	---	X				
	Replace -----	---	X				
	Housing; home; pipe; fittings						
	Replace -----	---	X				
0504	Water Pump						
	Pump, water						
	Service -----	X					
	Replace -----	---	X				
	Repair -----	---	---	X			
0505	Fan Assembly						
	Fan; guard						
	Replace -----	---	X				
	Belt						
	Adjust -----	X					
	Replace -----	---	X				
06	ELECTRICAL SYSTEM						
0601	Generator						
	Generator assembly						

Functional group	Components and related operation	Levels of maintenance					Remarks
		O/C	O	DS	GS	D	
0602	Test -----		X				
	Replace -----		X				
	Repair -----	----	----	X			
	Belt						
	Adjust -----	X					
	Replace -----	----	X				
	Brushes						
	Replace -----	----	X				
	Generator Regulator						
	Regulator						
0603	Adjust -----	----	X				
	Test -----	----	X				
	Replace -----	----	X				
0605	Starting Motor						
	Starter						
	Service -----	X					
	Replace -----	----	X				
0606	Repair -----	----	----	X			
	Brushes; solenoid						
	Replace -----	----	X				
	Ignition Components						
	Distributor						
	Service -----	----	X				
	Adjust -----	----	X				
	Replace -----	----	X				
	Repair -----	----	----	X			
	Points; condenser, rotor wiring						
0607	Replace -----	----	X				
	Coil						
	Test -----	----	X				
	Replace -----	----	X				
	Spark plugs						
	Service -----	----	X				
	Adjust -----	----	X				
	Test -----	----	X				
	Replace -----	----	X				
	Engine Safety Controls						
0607	Governor, overspeed						
	Replace -----	----	X				
	Repair -----	----	----	----	----	X	
	Drive						
	Service -----	X					
	Replace -----	----	X				
	Engine Control Panel						
	Panel and box						
	Replace -----	----	----	X			
	Wiring						
Replace -----	----	----	X				
Repair -----	----	X					
Switches; lights; gages							
Replace -----	----	X					
Lamps							
Replace -----	X						

Functional group	Components and related operation	Levels of maintenance					Remarks
		O/C	O	DS	GS	D	
0608	Miscellaneous Items						
	Slave receptacle; buss bar						
	Replace -----	----	X				
	Cable						
	Replace -----	----	X				
	Repair -----	----	X				
0609	Lights						
	Lights						
	Replace -----	----	X				
	Lamps; doors; lens; gaskets						
	Replace -----	----	X				
0610	Sending Units						
	Sending units						
	Replace -----	----	X				
0611	Horn						
	Horn; button; wiring						
	Replace -----	----	X				
0612	Batteries						
	Batteries						
	Service -----	X					
	Test -----	----	X				
	Replace -----	----	X				
	Box, battery						
	Replace -----	----	X				
	Cables						
	Replace -----	----	X				
	Repair -----	----	X				
0613	Hull Wiring Harness						
	Wiring, cab						
	Replace -----	----	X				
	Repair -----	----	X				
	Conduit						
	Replace -----	----	X				
0616	Radio Interference Suppression						
	Components						
	Replace -----	----	X				
15	FRAME						
1502	Counterweights						
	Counterweight; roller						
	Replace -----	----	X				
18	CAB						
1801	Cab Assembly						
	Cab assembly						
	Replace -----	----	----	----	X		
	Repair -----	----	X				
1806	Upholstery Seats						
	Seat						
	Replace -----	----	X				
	Repair -----	----	X				
1808	Boxes						
	Box, tool						
	Replace -----	----	X				

AGO 6819A

Functional group	Components and related operation	Levels of maintenance					Remarks
		O/C	O	DS	GS	D	
22	MISCELLANEOUS AND ACCESSORY ITEMS						Includes Trouble Light and Reel; and Sling
2202	Accessory Items----- Accessories ----- Replace ----- Repair -----	----	X				
2210	Data Plates ----- Plates, data Replace ----- Plates, instruction Replace -----	----	X				
32	BASIC ISSUE ITEMS TROOP INSTALLED						
3200	Basic Issue Items Troop Installed or Authorized Accessories; tools, common; publications Replace -----	X					
43	HYDRAULIC SYSTEM						
4300	Hydraulic System Hydraulic system Service ----- Inspect -----	X					
4301	Hose, Pipe, Fitting, Tubing Hose and fittings Replace ----- Packing gland; tubing Replace ----- Repair -----	----	X				
4805	Manifold and/or Control Valves Cylinder, master Replace ----- Repair -----	----	X				
4807	Hydraulic Cylinders Cylinders, hydraulic Replace ----- Repair -----	----	X				
4309	Manual Controls Controls Replace -----	----	X				
74	CRANES, SHOVELS, AND EARTH MOVING EQUIPMENT COMPONENTS						
7410	Shovel Front Attachments Shovel front attachment Service ----- Adjust ----- Replace ----- Repair ----- Overhaul ----- Boom, shovel Replace ----- Repair ----- Sprockets Replace ----- Repair -----	X X X ---- ---- ---- ---- ---- ---- ---- ---- ---- ---- ---- ----	X X X X X X X X X X X X X X X			X X X X X X X X X X X X	

Functional group	Components and related operation	Levels of maintenance					Remarks
		O/C	O	DS	GS	D	
7411	Shaft, shifter						
	Replace -----	----	----	X			
	Repair -----	----	----	X			
	Chain						
	Adjust -----	X					
	Replace -----	----	X				
	Repair -----	----	X				
	Tightener						
	Replace -----	----	X				
	Repair -----	----	X				
	Dipper; pulley assembly; pad-lock; stick assembly						
	Replace -----	----	X				
	Repair -----	----		X			
	Braces, pitch; mechanism, dipper						
	Adjust -----	X					
	Replace -----	----	X				
	Teeth, dipper						
	Replace -----	X					
	Magnetic switch, solenoid and push button						
	Replace -----	----	X				
	Wire assembly						
	Replace -----	----	X				
	Repair -----	----	X				
	Crane Dragline or Clamshell Attachments						
	Boom, crane						
	Service -----	X					
	Replace -----	X					
	Repair -----	----	X				
	Pulley; roller, guide						
	Replace -----	----			X		
	Repair -----	----			X		
	Block, hook						
	Service -----	X					
	Replace -----	X					
	Repair -----	----			X		
	Tagline						
	Service -----	X					
	Adjust -----	X					
	Replace -----	X					
	Repair -----	----	X				
Stop boom and bridle assembly							
Replace -----	----	X					
Repair -----	----	X					
Bucket, clamshell and dragline							
Service -----	X						
Replace -----	X						
Repair -----	----	X					
Teeth, bucket							
Replace -----	X						
Cable, dump							
Adjust -----	X						
Replace -----	X						



Functional group	Components and related operation	Levels of maintenance					Remarks
		O/C	O	DS	GS	D	
7412	Fairlead; boom harness						
	Service-----	X					
	Replace-----	X					
	Rollers						
	Replace-----	---	X				
	Repair-----	---	---	X			
	Boom, jib; mast						
	Service-----	X					
	Replace-----	X					
	Repair-----	---	X				
	Cables						
	Adjust-----	X					
	Replace-----	X					
	Pulleys						
	Replace-----	---	X				
	Repair-----	---	---	X			
	Sockets; pins						
	Replace-----	X					
	Backhoe Attachments						
	Backhoe						
	Service-----	X					
	Replace-----	X					
	Repair-----	---	X				
	Overhaul-----	---	---	---	X		
	Boom assembly, backhoe						
	Replace-----	---	X				
	Repair-----	---	---	X			
	Derrick assembly						
	Replace-----	---	X				
	Repair-----	---	X				
	Brace, back, dipper						
	Replace-----	---	X				
Teeth							
Replace-----	X						
Dipper assembly							
Adjust-----	X						
Replace-----	---	X					
Repair-----	---	X					
Bracket assembly; block and link assembly, pulley							
Replace-----	---	X					
Repair-----	---	---	X				
7413	Pile Drive Attachments						
Pile driving rig							
Service-----	X						
Replace-----	X						
Repair-----	---	X					
7414	Base Deck						
Frame assembly, revolving							
Service-----	X						
Replace-----	---	---	---	X			
7415	Clutch						
Clutch assemblies							
Service-----	X						
Adjust-----	X						
Replace-----	---	---	---	X			
Repair-----	---	---	---	X			

Functional group	Components and related operation	Levels of maintenance					Remarks
		O/C	O	DS	GS	D	
7416	Shoes, clutch						
	Replace-----	----	X				
	Repair-----	----		X			
	Guard; clutch, jaw						
	Replace-----	----	X				
	Shafts						
	Shaft assemblies						
	Service-----	X					
	Replace-----	----			X		
	Repair-----	----			X		
Bands, brake							
Adjust-----	X						
Replace-----	----	X					
Repair-----	----		X				
Guards; gear, spur, vertical							
Replace-----	----	X					
7419	Turntable						
Rollers, rear							
Service-----	X						
Replace-----	----	X					
Repair-----	----	X					
Roller assembly, front							
Service-----	X						
Replace-----	----			X			
Repair-----	----	X					
Lock assembly, swing							
Replace-----	----	X					
Repair-----	----	X					
7420	Machinery Gear Case and Frame						
Case, gear							
Replace-----	----			X			
Frame, machinery							
Replace-----	----				X		
Repair-----	----				X		
7421	Independent or Precision Boom						
Hoist							
Shaft assembly							
Service-----	X						
Replace-----	----				X		
Repair-----	----				X		
Bands, brake							
Adjust-----	X						
Replace-----	----	X					
Repair-----	----			X			
7422	Machine Mechanism Controls						
Rods, levers; pedals; shafts; linkage							
Replace-----	----	X					
Bearings, sleeve							
Replace-----	----	X					
7428	Gantry						
Frame, gantry							
Replace-----	----			X			
Repair-----	----	X					
7499	Cables						
Cables							
Inspect-----	X						
Replace-----	X						

Functional group	Components and related operation	Levels of maintenance					Remarks
		O/C	O	DS	GS	D	
76	FIRE FIGHTING EQUIPMENT						
7603	COMPONENTS						
	Fire Extinguishers						
	Extinguisher, fire						
	Service -----	X					
	Replace -----	X					
01	CARRIER SECTION						
0100	ENGINE ASSEMBLY						
	Engine Assembly						
	Engine						
	Service -----	X					
	Inspect -----	X					
	Test -----	---	X				Compression
	Replace -----	---	---		X		
	Repair -----	---	X				
	Overhaul -----	---	---		X		
0101	Crankcase, Cylinder Head						
	Crankcase						
	Replace -----	---	---		X		
	Repair -----	---	---		X		
	Cylinder head						
	Replace -----	---	---	X			
	Repair -----	---	---	X			
0102	Crankshaft						
	Crankshaft assembly						
	Replace -----	---	---		X		
	Repair -----	---	---		---	X	Metalize, Grind, Aline
	Bearings, main						
	Replace -----	---	---		X		
	Dampers; drive pulley; crank-jaw						
	Replace -----	---	---	X			
0103	Flywheel Assembly						
	Flywheel						
	Replace -----	---	---		X		Replace Ring Gear
	Repair -----	---	---		X		
	Housing, flywheel						
	Replace -----	---	---		X		
0104	Piston, Connecting Rods						
	Pistons; rings; pins; Retainers						
	Replace -----	---	---		X		
	Bearing, rod						
	Replace -----	---	---		X		
	Rods, connecting						
	Replace -----	---	---		X		
	Repair -----	---	---		X		
0105	Valves, Camshafts and Timing System						
	Valves and inserts						
	Replace -----	---	---	X			
	Repair -----	---	---	X			
	Springs; guide; locks; rods, push						
	Replace -----	---	---	X			

Functional group	Components and related operation	Levels of maintenance					Remarks
		O/C	O	DS	GS	D	
0106	Arms, rocker						
	Adjust-----	----	X				
	Replace-----	----		X			
	Repair-----	----		X			
	Gaskets and covers						
	Replace-----	----	X				
	Tappets; camshaft; bushings; gears, timing						
	Replace-----	----			X		
	Engine Lubrication System						
	Pump assembly, oil; pan, oil						
	Replace-----	----			X		
	Repair-----	----			X		
	Cooler, oil						
	Replace-----	----	X				
	Filter assembly, oil						
	Service-----	X					
	Replace-----	----	X				
Repair-----	----	X					
Valves; fittings							
Replace-----	----	X					
Breather							
Service-----	X						
Replace-----	----	X					
Gage, level							
Replace-----	X						
Lines							
Replace-----	----	X					
Repair-----	----	X					
0108	Manifolds						
Manifold assembly							
Replace-----	----	X					
Repair-----	----	X					
0109	Accessory Drive Mechanism						
Shaft; housing; coupling							
Replace-----	----	X					
02	CLUTCH ASSEMBLY						
0200	Clutch Assembly						
Clutch assembly							
Service-----	X						
Adjust-----	----	X					
Replace-----	----			X			
Repair-----	----			X			
0202	Clutch Release Mechanism						
Clutch, release							
Replace-----	----			X			
Repair-----	----			X			
Linkage, clutch							
Adjust-----	X						
Replace-----	----	X					
03	FUEL SYSTEM						
0301	Carburetor						
Carburetor							
Service-----	X						
Adjust-----	X						
Replace-----	----	X					
Repair-----	----			X			

Functional group	Components and related operation	Levels of maintenance					Remarks
		O/C	O	DS	GS	D	
0302	Fuel Pumps						
	Pump, fuel						
	Replace -----	----	X				
0304	Air Cleaner						
	Air cleaner						
	Service -----	X					
	Replace -----	----	X				
	Repair -----	----	X				
	Hose						
	Replace -----	----	X				
0306	Tanks, Lines, Fittings						
	Tank						
	Service -----	X					
	Replace -----	----	X				
	Cap; fittings						
	Replace -----	----	X				
	Lines						
	Replace -----	----	X				
	Repair -----	----	X				
0308	Engine Speed Governor						
	Governor assembly						
	Replace -----	----	X				
	Repair -----	----		----	----	X	
	Drive						
	Service -----	X					
	Replace -----	----	X				
0309	Fuel Filters						
	Filter, fuel						
	Service -----	X					
	Replace -----	----	X				
0311	Engine Starting Aids						
	Fittings						
	Replace -----	----	X				
	Lines						
	Replace -----	----	X				
	Repair -----	----	X				
0312	Accelerator, Choke Controls						
	Controls, accelerator						
	Replace -----	----	X				
	Repair -----	----	X				
	Choke						
	Replace -----	----	X				
04	EXHAUST SYSTEM						
0401	Muffler and Pipes						
	Muffler; pipes; clamps						
	Replace -----	----	X				
05	COOLING SYSTEM						
0501	Radiator						
	Radiator						
	Service -----	X					
	Replace -----	----		X			
	Cap						
	Replace -----	X					
0503	Water Headers, Thermostats and Housing Gasket						
	Headers, water						
	Replace -----	----	X				

Functional group	Components and related operation	Levels of maintenance					Remarks
		O/C	O	DS	GS	D	
0504	Thermostat						
	Test -----	----	X				
	Replace -----	----	X				
	Housing and gasket						
	Replace -----	----	X				
	Water Pump						
	Pump, water						
	Service -----	X					
	Replace -----	----		X			
	Repair -----	----		X			
0505	Fan Assembly						
	Fan; blade						
	Replace -----	----	X				
	Belt						
	Adjust -----	X					
	Replace -----	----	X				
06	ELECTRICAL SYSTEM						
0601	Generator						
	Generator						
	Test -----	----	X				
	Replace -----	----	X				
	Repair -----	----		X			
	Brushes						
	Replace -----	----	X				
0602	Generator Regulator						
	Regulator, generator						
	Test -----	----	X				
	Replace -----	----	X				
0603	Starting Motor						
	Starter						
	Service -----	X					
	Replace -----	----	X				
	Repair -----	----		X			
	Brushes; solenoid switch						
	Replace -----	----	X				
0605	Ignition Components						
	Distributor						
	Service -----	----	X				
	Adjust -----	----	X				
	Replace -----	----	X				
	Repair -----	----		X			
	Cap; condenser; points;						
	Wiring; rotor						
	Replace -----	----	X				
	Coil						
	Test -----	----	X				
	Replace -----	----	X				
	Spark plugs						
	Service -----	----	X				
	Adjust -----	----	X				
	Test -----	----	X				
	Replace -----	----	X				
0606	Engine Safety Controls						
	Switches						
	Replace -----	----	X				

Functional group	Components and related operation	Levels of maintenance					Remarks
		O/C	O	DS	GS	D	
0607	Instrument or Engine Control Panel						
	Panel						
	Replace -----	----	----	X			
	Wiring harness						
0608	Replace -----	----	----	X			
	Repair -----	----	X				
	Switches; gages; lights						
	Replace -----	----	X				
	Lamp						
	Replace -----	X					
	Miscellaneous Items						
	Switch, stoplight and turn						
	Replace -----	----	X				
	Flasher unit and fuse						
	Replace -----	X					
	Receptacle, slave; cables						
	Replace -----	----	X				
	Repair -----	----	X				
Switches, transmission control							
Replace -----	----	X					
Wiring transmission control							
Replace -----	----	X					
Repair -----	----	X					
0609	Lights						
	Lights; sealed unit; doors; lenses; lamps; gaskets						
0610	Replace -----	----	X				
	Sending Units						
0611	Sending units						
	Replace -----	----	X				
0612	Horn						
	Button						
	Replace -----	----	X				
	Wiring						
0613	Replace -----	----	X				
	Repair -----	----	X				
	Batteries						
	Batteries						
	Service -----	X					
	Test -----	----	X				
	Replace -----	----	X				
	Cables						
	Replace -----	----	X				
	Repair -----	----	X				
Box, battery							
Replace -----	----	X					
0613	Chassis Wiring Harness						
	Cab and chassis wiring						
	Replace -----	----	----	X			
	Repair -----	----	X				
	Coupling, trailer						
Replace -----	----	X					

Functional group	Components and related operation	Levels of maintenance					Remarks
		O/C	O	DS	GS	D	
07	TRANSMISSION						
0700	Transmission Assembly						
	Transmission assembly						
	Service-----	X					
	Inspect-----	X					
	Replace-----	---	---	X			
	Repair-----	---	---	X			
	Overhaul-----	---	---	---	X		
	Case, transmission						
	Replace-----	---	---	---	X		
0701	Transmission Shafts						
	Shafts; gears; bearings						
	Replace-----	---	---	---	X		
0704	Transmission Top Cover Assembly						
	Cover assembly						
	Replace-----	---	---	X			
	Repair-----	---	---	X			
	Shafts and rods, control						
	Replace-----	---	X				
	Repair-----	---	X				
	Lever						
	Replace-----	---	X				
08	TRANSFER ASSEMBLY						
0801	Power Transfer Assembly						
	Transfer assembly						
	Service-----	X					
	Inspect-----	X					
	Replace-----	---	---	X			
	Repair-----	---	---	---	X		
0803	Gear Shift and Controls						
	Levers						
	Service-----	X					
	Replace-----	---	X				
	Repair-----	---	X				
	Rod; shaft; fittings; balljoint						
	Replace-----	---	X				
0804	Lubrication Components						
	Breathers						
	Service-----	X					
	Replace-----	---	X				
09	PROPELLER SHAFTS						
0900	Propeller Shafts						
	Shaft assemblies						
	Service-----	X					
	Replace-----	---	X				
	Repair-----	---	X				
10	FRONT AXLE						
1000	Front Axle Assembly						
	Axle assembly						
	Service-----	X					
	Inspect-----	X					
	Replace-----	---	---	X			
	Repair-----	---	---	X			
	Overhaul-----	---	---	---	X		
	Breather						
	Service-----	X					
	Replace-----	---	X				



Functional group	Components and related operation	Levels of maintenance					Remarks
		O/C	O	DS	GS	D	
1002	Differential						
	Differential assembly						
	Replace -----	----	----	X			
	Repair -----	----	----	X			
1004	Steering Mechanism						
	Knuckle; shafts						
	Replace -----	----	----	X			
	Repair -----	----	----	X			
	Arm; flange; shims						
	Replace -----	----	----	X			
	Flange, drive						
	Replace -----	----	X				
11	REAR AXLE						
1100	Rear Axle Assembly						
	Axle assembly						
	Service -----	X					
	Inspect -----	X					
	Replace -----	----	----	----	X		
	Repair -----	----	X				
	Overhaul -----	----	----	----	X		
	Shafts, axle						
	Replace -----	----	X				
	Breather						
	Service -----	X					
	Replace -----	----	X				
1101	Housing, Plugs						
	Housing						
	Replace -----	----	----	----	X		
1102	Differential						
	Differential assembly						
	Replace -----	----	----	----	X		
	Repair -----	----	----	----	X		
1103	Walking Beams						
	Walking beams						
	Replace -----	----	----	----	X		
	Repair -----	----	----	----	X		
12	BRAKES						
1201	Hand Brakes						
	Brakes, hand						
	Replace -----	----	----	X			
	Repair -----	----	X				
	Linkage						
	Adjust -----	X					
	Replace -----	----	X				
	Lever						
	Replace -----	----	X				
1202	Service Brakes						
	Brakes, services						
	Adjust -----	----	X				
	Replace -----	----	----	X			
	Repair -----	----	----	X			
	Shoes						
	Replace -----	----	X				
	Repair -----	----	----	X			

Functional group	Components and related operation	Levels of maintenance					Remarks
		O/C	O	DS	GS	D	
1206	Mechanical Brake System						
	Adjuster, slack						
	Service -----	X					
	Adjust -----	---	X				
	Replace -----	---	X				
1208	Air Brake System						
	Chambers, brake; valve						
	Replace -----	---	X				
	Repair -----	---	---	X			
	Evaporator assembly						
	Replace -----	---	X				
	Repair -----	---	X				
	Reservoir						
	Service -----	X					
	Replace -----	---	X				
	Lines						
	Replace -----	---	X				
	Repair -----	---	X				
	Fittings; valves						
	Replace -----	---	X				
1209	Air Compressor Assembly						
	Compressor assembly						
	Service -----	X					
	Inspect -----	X					
	Replace -----	---	X				
	Repair -----	---	---	X			
1211	Trailer Brake Connections and Controls						
	Valves; fittings; coupling						
	Replace -----	---	X				
	Lines						
	Replace -----	---	X				
	Repair -----	---	X				
13	WHEELS						
1311	Wheel Assembly						
	Wheel assembly						
	Replace -----	---	X				
	Hub; seals; drums						
	Replace -----	---	X				
	Bearings						
	Service -----	---	X				
	Replace -----	---	X				
1318	Tires, Tubes						
	Tires						
	Service -----	X					
	Replace -----	---	X				
	Tubes						
	Replace -----	---	X				
	Repair -----	---	X				
14	STEERING						
1401	Steering Assembly						
	Gear hydraulic						
	Service -----	X					
	Replace -----	---	X				
	Repair -----	---	---	X			

Functional group	Components and related operation	Levels of maintenance					Remarks
		O/C	O	DS	GS	D	
1410	Wheel, steering; universal; arms; shaft						
	Replace -----	---	X				
	Tie rod; drag link						
	Service -----	X					
	Replace -----	---	X				
	Repair-----	---	X				
	Hydraulic Pump						
	Pump assembly						
	Replace -----	---	X				
	Repair-----	---	---	X			
Belt							
Adjust -----	X						
Replace -----	---	X					
Pulley							
Replace -----	---	X					
1411	Hose, Lines, Fittings						
Hose, lines, fitting							
Replace -----	---	X					
1412	Hydraulic Cylinders						
Cylinders, hydraulic							
Replace -----	---	---	X				
Repair-----	---	---	X				
1413	Reservoir						
Reservoir							
Service -----	X						
Replace -----	---	X					
Repair-----	---	X					
1414	Steering System Valves						
Valves							
Replace -----	---	X					
Repair-----	---	---	X				
15	FRAME ASSEMBLY						
1501	Frame Assembly						
Frame assembly							
Replace -----	---	---	---	X			
Boom rest							
Replace -----	---	---	X				
Repair-----	---	---	X				
1503	Pintles						
Pintle							
Service -----	---	X					
Replace -----	---	---	X				
Repair-----	---	---	X				
1507	Leveling Jacks						
Outrigger, front							
Service -----	---	X					
Replace -----	---	---	X				
Repair-----	---	---	X				
Outrigger, rear							
Service -----	---	X					
Replace -----	---	X					
Repair-----	---	---	X				

Functional group	Components and related operation	Levels of maintenance					Remarks
		O/C	O	DS	GS	D	
16	SPRING AND SHOCK ABSORBERS						
1601	Springs						
	Springs, front						
	Service -----	----	X				
	Replace -----	----	----		X		
	Repair-----	----	----		X		
1604	Shock Absorber Equipment						
	Absorbers, shock						
	Replace -----	----	----	X			
1605	Torque Rods						
	Rods, Torque						
	Service -----	----	X				
	Replace -----	----	----	X			
	Repair-----	----	----	X			
18	BODY, CAB, HOOD ASSEMBLIES						
1801	Body, Cab, Hood Assemblies						
	Cab, assembly						
	Replace -----	----	----	X			
	Repair-----	----	X				
	Fenders; hood; panels						
	Replace -----	----	X				
	Fender, left front						
	Replace -----	----	----	----	X		
18"	Upholstery, Seats and Carpets						
	Seat						
	Replace -----	----	X				
	Repair-----	----	X				
22	ACCESSORY ITEMS						
2202	Accessory Items						
	Accessory items						
	Replace -----	----	X				
	Blade, wiper						
	Replace -----	X					
	Windshield washer; trouble light						
	Replace -----	----	X				
	Repair-----	----	X				
2210	Data Plate						
	Plate, data						
	Replace -----	----	----	X			
	Plates, caution and instruction						
	Replace -----	----	X				
26	TOOLS AND TEST EQUIPMENT						
2604	Special Tools						
	Tools, special						
	Replace -----	----	----	X			
31	BASIC ISSUE ITEMS, MANUFACTURER						
	INSTALLED						
3100	Basic Issue Items, Manufacturer or Depot Installed						
	Accessories						
	Replace -----	X					

AGO 6819A

Functional group	Components and related operation	Levels of maintenance					Remarks
		O/C	O	DS	GS	D	
32	BASIC ISSUE ITEMS TROOPS INSTALLED						
3200	Basic Issue Items Troops Installed or Authorized Tools, common						
	Replace -----	X					
	Publications						
	Replace -----	X					
43	AIR SYSTEM						
4316	Hose, Lines, Fittings, Filter						
	Hose, lines, fittings, transmission controls						
	Replace -----	---	X				
	Filter						
	Service -----	X					
	Replace -----	---	X				
4317	Control Valves						
	Valve, regulator, transmission controls						
	Replace -----	---	X				
47	GAUGES						
4701	Instruments Speed and Distance						
	Speedometer						
	Replace -----	---	X				
	Drive						
	Service -----	X					
	Replace -----	---	X				
50	PNEUMATIC EQUIPMENT						
5001	Crankcase, Block, Cylinder Head						
	Crankcase; block; head, cylinder						
	Replace -----	---	---	X			
5002	Crankshaft						
	Crankshaft						
	Replace -----	---	---	X			
	Bearings						
	Replace -----	---	---	X			
5004	Pistons, Connecting Rods						
	Pistons; rods, connecting; rings						
	Replace -----	---	---	X			
5006	Valves and Timing Mechanism						
	Valves; springs; guides						
	Replace -----	---	---	X			
5006	Lubrication System						
	Base						
	Replace -----	---	X				
5007	Compressor Drive						
	Pulley						
	Replace -----	---	X				
	Belt						
	Adjust -----	---	X				
	Replace -----	---	X				
5008	Air Takes						
	Strainer						
	Service -----	X					
	Replace -----	---	X				

Functional group	Components and related operation	Levels of maintenance					Remarks
		O/C	O	DS	GS	D	
76	FIRE FIGHTING EQUIPMENT						
	COMPONENTS						
7603	Fire Extinguishers						
	Extinguisher, fire						
	Service -----	X					
	Replace -----	X					
	WINTERIZATION SECTION						
01	ENGINE						
0102	Crankshaft						
	Pulley						
	Replace -----	---	---	X			
0106	Engine Lubrication System						
	Oil pan						
	Replace -----	---	---	X			
	Repair-----	---	---	X			
05	COOLING SYSTEM						
0601	Radiator						
	Shutters						
	Replace -----	---	X				
	Repair-----	---	X				
0505	Fan Assembly						
	Fan guard						
	Replace -----	---	X				
06	ELECTRICAL SYSTEM						
0607	Instrument or Engine Control Panel						
	Electric tachometer gauge, speedometer, drives						
	Replace -----	---	X				
	Wiring harness						
	Replace -----	---	X				
	Repair-----	---	X				
0612	Batteries						
	Boxes; cables						
	Replace -----	---	X				
	Repair-----	---	X				
18	BODY, CAB, HOOD ASSEMBLIES						
1801	Body, Cab, Hood Assemblies						
	Cab assembly						
	Replace -----	---	---	X			
	Repair-----	---	X				
	Hood; panels						
	Replace -----	---	X				
1806	Carpets						
	Replace -----	---	X				
22	ACCESSORY ITEMS						
2202	Accessory Items						
	Defrosters; tubes and adapters						
	Replace -----	---	X				
	Heaters; boxes, control; wiring						
	Replace -----	---	X				
	Repair-----	---	X				
	Wiring harness and terminal block						
	Replace -----	---	X				
	Wiper assembly, arm						
	Replace -----	---	X				

AGO 6819A

Functional group	Components and related operation	Levels of maintenance					Remarks
		O/C	O	DS	GS	D	
2207	Blade, wiper						
	Replace -----	X					
	Linen and fittings						
	Replace -----	---	X				
	Repair-----	---	X				
	Winterization Equipment						
	Heater assembly; boxes, control; wiring						
	Replace -----	---	X				
	Repair-----	---	X				
	Pump, coolant						
	Replace -----	---	X				
	Pump, fuel; alter						
	Service -----	X					
	Replace -----	---	X				
	Lines, fuel coolant						
	Replace -----	---	X				
	Repair-----	---	X				
	Wiring harness; fitting						
	Replace -----	---	X				
Pipe, exhaust							
Replace -----	---	X					
Thermostat assembly							
Replace -----	---	X					
Alcohol dispenser							
Service -----	X						
Replace -----	---	X					
50	PNEUMATIC EQUIPMENT						
5000	Air Compressor Assembly						
	Air compressor						
	Service -----	X					
	Inspect-----	X					
	Replace -----	---	X				
	Repair-----	---	X				
5001	Crankcase, Block, Cylinder Head						
	Crankcase, block						
	Replace -----	---	---	X			
	Cylinder head						
	Replace -----	---	---	X			
	Repair-----	---	---	X			
5002	Crankshaft						
	Crankshaft						
	Replace -----	---	---	X			
5004	Pistons, Connecting Rods						
	Pistons, rods						
	Replace -----	---	---	X			
5005	Valves						
	Valves; springs; seats, guides						
	Replace -----	---	---	X			
5006	Lubrication System						
	Base; pump oil						
	Replace -----	---	---	X			
	Gauge and breather						
	Replace -----	---	---	X			

Functional group	Components and related operation	Levels of maintenance					Remarks
		O/C	O	DS	GS	D	
5007	Compressor Drive						
	Belts						
	Adjust -----	X					
5008	Replace -----	---	X				
	Pulley						
	Replace -----	---	X				
	Air Intakes						
5009	Strainer assembly						
	Service -----	X					
	Replace -----	---	X				
5014	Repair-----	---	X				
	Unloader System Components						
	Spring; guide; plunger						
5015	Replace -----	---	---	X			
	Piston assembly, unloader						
	Replace -----	---	---	X			
5014	Repair-----	---	---	X			
	Air Receiver						
5015	Service -----	X					
	Replace -----	---	X				
	Air Discharge System						
5015	Line						
	Replace -----	---	X				
	Repair-----	---	X				
5015	Fittings						
	Replace -----	---	X				



## APPENDIX III

### BASIC ISSUE ITEMS LIST AND MAINTENANCE AND OPERATING SUPPLIES

---

#### Section I. INTRODUCTION

##### 1. General

Section II lists the accessories, tools, and publications required for maintenance and operation by the operator, initially issued with, or authorized for the Crane-Shovel. Section III lists the maintenance and operating supplies required for initial operation.

##### 2. Explanation of Columns Contained in Section II

a. *Source Codes.* The information provided in each column is as follows:

- (1) *Materiel.* This column lists the basic materiel code number of the supply service assigned responsibility for the part. Blank spaces denote supply responsibility of the preparing agency. General Engineer supply parts are identified by the letters "GE" in parentheses, following the nomenclature in the description column. Other basic materiel code numbers are:

9—Ordnance Materiel  
10—Quartermaster materiel  
12—Adjutant General

- (2) *Source.* The selection status and source of supply for each part are indicated by one of the following code symbols:

- (a) P—applied to high-mortality repair parts which are stocked in or supplied from the supply service depot system, and authorized for use at indicated maintenance level.
- (b) P1—applied to repair parts which are low-mortality parts, stocked in or supplied from supply service depots, and authorized for installation at indicated maintenance level.

- (3) *Maintenance.* The lowest maintenance level authorized to use, stock, install, or manufacture the part is indicated by the following code symbol:

O—Organizational Maintenance

- (4) *Recoverability.* When no code is shown in the recoverability column the part is considered expendable.

b. *Federal Stock Number.* The Federal stock number will be shown in this column, and will be used for requisitioning purposes.

c. *Description.*

- (1) The item name and a brief description of the part are shown.
- (2) A five-digit Federal supply code for manufacturers and/or other supply services is shown in parentheses followed by the manufacturer's part number. This number shall be used for requisitioning purposes when no Federal stock number is indicated in the Federal stock number column.

Example: (08646) 86648

d. *Unit of Issue.* If no abbreviation is shown in this column, the unit of issue is "each."

e. *Quantity Authorized.* This column lists the quantities of repair parts, accessories, tools, or publications authorized for issue to the equipment operator or crew as required.

f. *Quantity issued with Equipment.* This column lists the quantities of repair parts, accessories, tools, or publication that are initially issued with each item of equipment. Those indicated by an asterisk are to be requisitioned through normal supply channels as required.

AGO 6819A

g. *Illustrations.* This column is subdivided into two columns which provide the following information:

- (1) *Figure number.* Provides the identifying number of the illustrations.
- (2) *Item number.* Provides the referenced number for the parts shown in the illustration.

### 3. Explanation of Columns Contained in Section III

a. *Item.* This column contains numerical sequenced item numbers, assigned to each component application, to facilitate reference.

b. *Component Application.* This column identifies the component application of each maintenance or operating supply item.

c. *Source of Supply.* This column lists the basic materiel code number of the supply service assigned responsibility for the item. Blank spaces denote supply responsibility of the preparing agency. Other basic materiel code numbers are:

9—Ordnance Materiel

10—Quartermaster Materiel

d. *Federal Stock Number.* The Federal stock number will be shown in this column and will be used for requisitioning purposes.

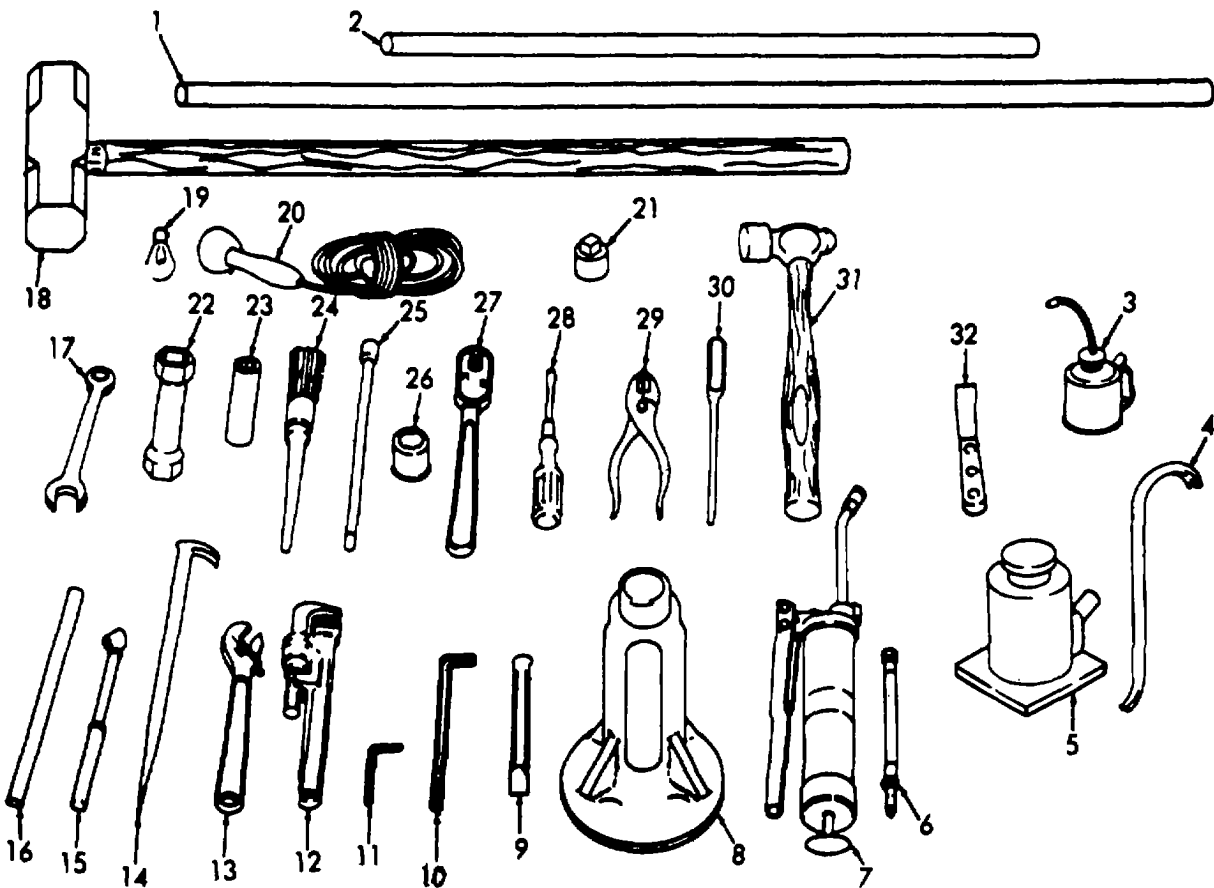

MEC 3810-227-15/293

- |                    |                       |                    |                |
|--------------------|-----------------------|--------------------|----------------|
| 1 Rod              | 9 Chisel              | 17 Wrench          | 25 Extension   |
| 2 Handle           | 10 Drain plug wrench  | 18 Hammer (sledge) | 27 Handle      |
| 3 Hand oiler       | 11 Socket head wrench | 19 Lamp            | 26 Socket      |
| 4 Wrecking bar     | 12 Pipe wrench        | 20 Extension light | 28 Screwdriver |
| 5 Jack, 20 ton     | 13 Wrench             | 21 Adapter         | 29 Pliers      |
| 6 Hose assembly    | 14 Pry bar            | 22 Wrench          | 30 Punch       |
| 7 Grease gun       | 15 Gage               | 23 Socket          | 31 Hammer      |
| 8 Wire rope cutter | 16 Steel drift        | 24 Paint brush     | 32 Putty knife |

Figure 293. Basic issue items.

e. *Description.* The item and a brief description are shown.

f. *Quantity Required for Initial Operation.* This column lists the quantity of each maintenance or operating supply item required for initial operation of the equipment.

g. *Quantity Required for 8 Hours Operation.* Quantities listed represent the estimated requirements for an average eight hours of operation.

h. *Notes.* This column contains informative notes keyed to data appearing in the preceding column.

### Section II. BASIC ISSUE ITEMS LIST

Code				Federal Stock No.	Description	Unit of Issue	Expendability	Qty authorized	Illustration	
Materiel Service	Source	Maint level	Recoverability						Fig. No.	Item. No.
a	b	c	d	e	f	g	h	i	j	k
					GROUP 31-BASIC ISSUE ITEMS, MANUFACTURER INSTALLED					
					3100-BASIC ISSUE ITEMS, MANUFACTURER OR DEPOT INSTALLED					
9	P	O		6140-057-2554	BATTERY: storage, 12V, 6 cell (Repair Parts Manual Group 0612).		4	4		
10	P	O		7510-889-8494	BINDER, Equipment Log Book-----		1	1		
	P	O		7520-559-9618	CASE: maintenance and operational manuals: cotton duck, water repellent, mildew resistant.		1	1		
12					DEPARTMENT OF THE ARMY LUBRICATION ORDER LO 5-3810-227-15.		1	1		
12					DEPARTMENT OF THE ARMY OPERATOR, ORGANIZATIONAL, DIRECT AND GENERAL SUPPORT, AND DEPOT MAINTENANCE MANUAL TM 5-3810-227-15.		2	2		
12					DEPARTMENT OF THE ARMY ORGANIZATIONAL MAINTENANCE REPAIR PARTS MANUAL TM 5-3810-227-20P.		2	2		
	P1	O			EXTINGUISHER: fire, dry chemical, charged, hand, pressurized, w/dry air or nitrogen gas; w/pressure gauge; squeeze grip control; steel cylinder; enameled red; factory mutual or UL approved, Class 4B, C; 2½ lb; w/universal bracket (Repair Parts Manual group 7608).		2	2		
9	P	O		4910-273-3662	GAUGE: tire pressure, 10 to 160 lbs range (Repair Parts Manual Group 4702).		1	1	293	15

AGO 6819A

Code				Federal Stock No.	Description	Unit of Issue	Expendability	Qty authorized	Illustration	
Materiel Service	Source	Maint level	Recoverability						Fig. No.	Item. No.
a	b	c	d	e	f	g	h	i	j	k
	P	O		6240-155-7790	LAMP: Incandescent, 28V, 21 cp, double contact, bayonet candelabra base, S-8 clear bulb (Repair Parts Manual Group 0608).		1	1	293	19
9	P	O		9510-089-0684	ROD: steel, round, 1 in. dia, cold finished, 24 in. rqr; outrigger adjusting.		1	1	293	1
9	P	O		6810-264-9063	SULFURIC ACID: electrolyte (Repair Parts Manual Group 0612).	Gal	7	7		
					GROUP 32—BASIC ISSUE ITEMS, TROOP INSTALLED					
					3200—BASIC ISSUE ITEMS, TROOP INSTALLED OR AUTHORIZED					
10	P	O		5120-240-8701	ADAPTER, SOCKET WRENCH: one end male 3/4 in. sq, other end female 1/2 in. sq. opening.		1	*	293	21
10	P	O		5120-224-1389	BAR: pry, rolling head, 1/2 in. dia, 16 in. lg.		1	*	293	14
10	P	O		5120-596-1019	BAR, WRECKING: 1 in. stock, 48 in. long.		1	*	293	4
	P	O		8020-239-0959	BRUSH, PAINT: oval, 1-7/16 x 1-1/16 in. tip.		1	*	293	24
10	P	O		5110-286-3272	CHISEL, COLD, HAND: 3/4 in. cut, 7 in. lg.		1	*	293	9
10	P	O		5110-241-8807	CUTTER: wire rope, hand operated, hammer impact, 1 in. maximum wire capacity.		1	*	293	8
10	P	O		5120-754-0840	DRIFT: steel, round, brass tip, 3/4 in dia, 10 in. lg.		1	*	293	16
10	P	O		5120-227-8704	EXTENSION: socket wrench, 1/2 in. sq. drive, 10 in. lg.		1	*	293	25
10	P	O		4930-360-2801	GREASE GUN: hand lever operated, 16-oz capacity.		1	*	293	7
10	P	O		5120-224-4046	HAMMER, HAND: machinist ball pean, 1 1/4 lb head		1	*	293	31
10	P	O		5120-251-4489	HAMMER, HAND: blacksmith's sledge, double face, 8 lb head.		1	*	293	18
10	P	O		5120-230-6385	HANDLE, SOCKET WRENCH: ratchet, 1/2 in. sq. drive.		1	*	293	27
10	P	O		5120-251-1102	HANDLE, WHEEL WRENCH: 3/4 in. dia, 20 in. lg.		1	*	293	2
10	P	O		4930-141-8311	HOSE ASSEMBLY. grease gun, hydraulic coupling one end, other end male connection, 1/8 in. NPTF, Me in. ID hose, 19-11/32 in. overall length.		1	*	293	6
10	P	O		5120-188-1788	JACK: automobile and motor truck, hydraulic, 20 ton.		1	*	293	5

AGO 6819A

Code				Federal Stock No.	Description	Unit of Issue	Expendability	Qty authorized	Illustration	
Material Service	Source	Maint level	Recoverability						Fig. No.	Item. No.
a	b	c	d	e	f	g	h	i	j	k
10	P	O		5120-221-1536	KNIFE, PUTTY: flexible blade, 14 in. wide.		1	*	293	32
	P	O		6230-268-9437	LIGHT, EXTENSION: 2 conductor, water resistant, 16 AWG cable, 60 feet long, NEC type, post-32 single contact bayonet fusible plug connector one end and lamp holder w/guard, reflector and two hooks other end, adjustable blackout shield.		1	*	293	20
10	P	O		4920-262-8868	OILER, HAND: pump, force fed, 16 oz capacity, flexible spout.		1	*	293	8
10	P	O		5120-223-7396	PLIERS, SLIPJOINT: straight nose, comb. w/cutter, 6 in. lg.		1		293	29
10	P	O		5120-240-8876	PUNCH, ALIGNING: 5-32 in. dia pt, 8 in. lg.		1	*	293	30
10	P	O		5120-293-3176	SCREWDRIVER, FLAT TIP: tip ¼ in. wide, blade 4 in. lg.		1	*	293	28
10	P	O		5120-227-7349	SCREWDRIVER, FLAT TIP: mtl w/wood inserts hdl 3/8 in. w/flared tip, 6 in. lg. blade		1	*	293	28
10	P	O		5120-189-7914	SOCKET, SOCKET WRENCH: ½ in. sq. drive, 12 pt 1-1/8 in. opng.		1	*	293	26
10	P	O		5120-261-2823	SOCKET, SOCKET WRENCH: deep, ¾ in. sq drive, 1-5/8 in. opng.		1	*	293	23
10	P	O		5120-228-9505	WRENCH, BOX AND OPEN END, COMB: 15 deg offset, 7/16 in. opng.		1	*	293	17
10	P	O		5120-184-8642	WRENCH, BOX AND OPEN END, COMB: 15 deg offset, 9/16 opng.		1	*	293	17
10	P	O		5120-184-8643	WRENCH, BOX AND OPEN END, COMB: 15 deg offset, 5/8 in. opng.		1	*	293	17
10	P	O		5120-228-9509	WRENCH, BOX AND OPEN END, COMB: 15 deg offset, 11/16 in. opng.		1	*	293	17
10	P	O		5120-228-9510	WRENCH, BOX AND OPEN END, COMB: 15 deg offset, ¾ in. opng.		1	*	293	17
10	P	O		5120-228-9513	WRENCH, BOX AND OPEN END, COMB: 15 deg offset, 15/16 in. opng.		1	*	293	17
10	P	O		5120-228-9516	WRENCH, BOX AND OPEN END, COMB: 15 deg offset, 1-1/8 in. opng.		1	*	293	17
10	P	O		5120-228-9518	WRENCH, BOX AND OPEN END, COMB: 15 deg offset, 1-5/16 in. opng.		1	*	293	17
10	P	O		5120-227-8834	WRENCH, BOX AND OPEN END, COMB: 15 deg offset, 1½ in. opng.		1	*	293	17
10	P	O		5120-322-6269	WRENCH, DRAIN PLUG: 90 deg offset, ½ in. sq male drive.		1	*	293	10
10	P	O		5120-240-5328	WRENCH, OPEN END, ADJUSTABLE: sgle-hd, 22½ deg angle, hv-duty, 8 in. nom lg overall, 0.947 in. max jaw opng.		1	*	293	13

AGO 6819A

Code				Federal stock No.	Description	Unit of Issue	Expend-ability	Qty auth-ORIZED	Illustration	
Material	Source	Maint level	Recover-ability						Fig. No.	Item. No.
a	b	c	d	e	f	g	h	i	j	k
10	P	O		5120-264-3796	WRENCH, OPEN END, ADJUST-ABLE: sgle-hd, 0 to 1.322 in. jaw opng cap., 12 in. nom lg overall.		1	*	293	18
10	P	O		5120-423-6728	WRENCH, OPEN END, ADJUST-ABLE: 0 to 1.698 in. jaw opng, 15 in. lg.		1	*	293	18
10	P	O		5120-240-5331	WRENCH, PIPE, ADJUSTABLE: 1/4 to 1 in. pipe cap., 10 in. lg.		1	*	293	12
10	P	O		5120-240-5300	WRENCH, SOCKET HEAD SCREW: hex, 3/16 in. across flats, L handle, 2 3/4 in. arm length		1	*	293	11
1	P	O		5120-449-8258	WRENCH, WHEEL STUD NUT: 1 1/2 in. hex; 13/16 in. sq x 14 1/2 in. lg.		1	*	293	22

**Section III. MAINTENANCE AND OPERATING SUPPLIES**

Item	Component application	Source of supply	Federal stock No.	Description	Quantity required for initial operation	Quantity required for 8 hours operation	Notes
1.	0101 CRANKCASE (1)			OIL, LUBRICATING: (2) 5 gal drum an follows:			(1) Includes quantity of oil to fill engine oil sync tern an follows: Crane Engine: 12 qt-Crankcase 2 qt-oil filter 2 qt-air cleaner Carrier Engine: 22 qt-Crankcase 2 qt-oil alter 4 qt-air cleaner (2) See C9100SL for additional data and requisitioning procedure (3) See Current LO for grade application and replacement intervals.  (4) Fuel tank capacities are as follows: Crane 50 gal Carrier 100 gal  (5) Average fuel consumption gallons per hour (GPH) of continuous operation as follows: Crane 7.6GPH Carrier 13.6GPH
		10	9150-265-9435	OE-30	(1)	(3)	
		10	9150-265-9428	OE-10	(1)	(3)	
		10	9150-242-7603	OES	(1)	(3)	
2.	0304 AIR CLEANED			OIL, LUBRICATING: (2)	(1)	(3)	
3.	0306 TANK FUEL			GASOLINE AUTOMOTIVE: bulk as follows: Automotive, combat			
4.	0601 RADIATOR	10	9130-160-1818	91A WATER:	(4)	(5)	
		9	6850-243-1990	ANTIFREEZE 55-gal drums as follows: ANTIFREEZE ETHYLENE Glycol	(6)		
		9	6850-174-1806	ANTIFREEZE: Compound Arctic			
5.	0700 TRANSMISSION			OIL LUBRICATING, GEAR: (2) 5-gal drum as follows:			
		10	9150-265-9442	OE-50	12 qt (8-main) (4 second- ary)	(3)	

Item	Component application	Source of supply	Federal stock No.	Description	Quantity required for initial operation	Quantity required for 8 hours operation	Notes
6.	0801 POWER TRANSFER ASSEMBLY CASE			OIL, LUBRICATING, GEAR: (2) 5-gal drums as follows:			(6) Cooling system capacities are as follows: Crane 28 qt Carrier 46 qt
		10	9150-577-5847	GO 140			
		10	9150-577-5844	GO 90	2 1/2 qt	(3)	
		10	9150-257-5440	GOS			
7.	1002 DIFFERENTIAL FRONT			OIL, LUBRICATING, GEAR: (8)	7 qt	(3)	(7) Use oil as prescribed in Item 1.
8.	1102 DIFFERENTIAL REAR			OIL, LUBRICATING, GEAR: (8)	12 qt ea.	(3)	(8) Use oil as prescribed in Item 6.
9.	1300 WHEELS			GREASE, AUTOMOTIVE AND ARTILLERY: 5 lb can as follows:			(9) Fuel for heaters is drawn from the main tank.
		10	9150-190-0906(2)	GAA	3 lb	(3)	
10.	1413 HYDRAULIC SYSTEM, POWER STEERING			HYDRAULIC FLUID PETROLEUM BASE: 1 gal can as follows:			(10) Heater fuel consumption, gallons per hour of continuous operation is as follows:
		10	9150-223-4134(2)	OHA	1 1/2 qt	(3)	Crane Engine .27GPH Carrier Engine .75GPH Carrier Personnel .27GPH
11.	2202 PERSONNEL HEATER			GASOLINE, AUTOMOTIVE	(9)	(10)	(11) Use grease as prescribed in Item 9.
12.	2207 ENGINE HEATERS			GASOLINE, AUTOMOTIVE	(9)	(10)	
13.	4307 HYDRAULIC CYLINDERS			HYDRAULIC FLUID, NON-PETROLEUM BASE, AUTOMOTIVE: 1-gal can as follows:			
		10	9150-252-6375(2)	HBA	2 qt ea	(3)	
14.	7415 SPRAG CLUTCH			OIL, LUBRICATING INSTRUMENT: 4 ounce spout can			
		10	9150-257-5449(2)	OAI	1/16 qt	(3)	



Item	Component application	Source of supply	Federal stock No.	Description	Quantity required for initial operation	Quantity required for 8 hours operation	Notes
15.	7420 PRIMARY DRIVE CHAIN CHASE (7)			OIL, LUBRICATING, GEAR:	2 qt	(3)	
16.	OIL CAN POINTS (7)			OIL, LUBRICATING	1/2 qt	(3)	
17.	GREASE POINTS (1)			GREASE, AUTOMOTIVE AND ARTULERY:	5 lb	(3)	
18.	EXPOSED GEARS	10	9150-234-5199(2)	OIL LUBRICATING, CHAIN ROPE-EXPOSED GEARS: 5 lb can as follows: CW 11B	2 lb	(3)	

## INDEX

	Paragraph	Page		Paragraph	Page
Accelerator linkage and controls			Belts:		
carrier .....	89	77	Carrier .....	145	113
Access panel, carrier engine .....	253	173	Crane .....	157	118
Accessory drive assembly, carrier engine.....	402-405	234,235	Blackout lights .....	114-116	102,103
Adjustment:.....			Block, engine:		
Belts .....	104,131	96,109	Carrier .....	466-469	256,257
Brakebands, hoist .....	191,192	136,137	Crane .....	378-381	228
Brakeshoe .....	241	164	Boom:		
Carburetor .....	86,93	76,83	Angle indicator .....	207	145
Clutch, carrier engine.....	178	127	Hoist shaft assembly.....	597-600	313,314
Clutch, crane .....	186-190	132-136	Hoist shaft clutch .....	186	132
Clutch, crane engine .....	185	132	Pulleys and .....	204	143
Distributor points .....	6c,99	9,89	Rack .....	206	145
Drive chain .....	196	138	Brake:		
Generator regulator .....	6c, 106	9, 96	Bands, hoist .....	191,192	136,137
Governor, engine .....	87, 94	77, 83	Chambers, front and rear.....	234	162
Headlight .....	117	104	Service, front and rear .....	502-509	282, 283
Jaw clutch .....	202	141	Shoes, front and rear .....	241,242	164,165
Load rollers .....	199	139	Swing .....	198	137
Sparkplugs.....	100	90	Breather, engine crankcase filler and:		
Steering .....	218	151	Carrier .....	160	120
Valve clearance .....	6c, 171	9,124,	Crane .....	165	122
.....	174	125	Bridle assembly .....	205	145
Air brake:					
Chamber, front and rear .....	482-489	276,277	Cab and chassis wiring harness:		
Relay .....	526-529	288	Carrier .....	113	102
Valve, double check .....	494-497	279	Crane .....	143	112
Valve, protection .....	522-625	287	Cables:		
Valve, quick release.....	514-17	285	Battery .....	103,130	94,109
Air cleaner, engine:.....			Care and application, crane ..	6g,12	9,19
Carrier .....	84	75	Spark plug .....	100,127	90,108
Crane .....	91	81	Camshaft assembly:		
Air compressor:			Carrier engine .....	458-461	254, 255
Carrier .....	478-481	273-276	Crane engine .....	370-373	225, 226
Crane .....	286	188	Carburetor assembly:		
Air emergency and service shutoff valves .....	240	164	Carrier engine .....	86, 382-385	76, 229
Air lines, hoses, and fittings, carrier .....	232	161	.....	385	
.....			Crane engine .....	98, 299-302	83,198, 199
Air pressure gage, carrier .....	233	162	Carrier:		
Air tank, wet and dry .....	239	163	Air cleaner, engine .....	84	75
Auxiliary shaft assembly, power... load lowering, crane .....	613-615	318,319	Air compressor assembly .....	478-481	273-276
Axle, rear .....	227	155	Batteries, cables and battery box .....	103	94
Batteries, cables, and battery box:			Brake assembly, service, front and rear .....	502-509	282, 283
Carrier .....	103	94	Breather, engine crankcase...	160	120
Crane .....	130	109	Carburetor .....	86, 382-385	76,229
Bearings, main, carrier engine .....	462-465	255,256			

	Paragraph	Page
Carrier-Continued.....		
Chamber assembly, front and rear, air brakes .....	482-489	276, 277
Controls and instruments .....	14	22
Differential assembly, front and rear .....	550-553, 566-669	295, 299-301
Distributor assembly .....	98, 99, 398-401	89, 233, 234
Engine assembly, removal.....	298	197
Equalizing beam assembly ....	562-565	298,299
Fan, fan belt and hydraulic.... steering pump belt .....	145,146	113
Filter, engine oil .....	161	121
Fuel pump .....	88	77
Fuel tanks, lines and fittings ..	85	76
Generator assembly .....	104-106, 390-393	96, 232, 233
Governor assembly .....	87,386 339	77,231
Handbrake .....	489-501	279-281
Heater .....	29,30, 570-581	38,303 308
Horn assembly .....	112,119	102,105
Instrument panel components	107	99
Lights .....	110,111, 114-118, 123	99,101, 102-104, 108
Linkage and controls, accelera- tor .....	89	77
Manifolds, intake and exhaust	169	122
Manifolds, water .....	151	116
Moisture ejector valve assembly	490-493	278
Muffler .....	168	122
Oil pressure relief valve, en- .. gine .....	162	121
Operation .....	19	31
Protection valve assembly, air brake .....	522-525	287
Quick release valve assembly, air brake .....	514-517	285
Radiator shroud .....	147	113
Relay assembly, air brake ....	526-529	288
Slave receptacle .....	120	106
Sparkplugs and cables .....	100	90
Spring assembly, front .....	554-557	296, 297
Starter assembly .....	101,102, 394-397	91, 94, 233
Steering .....	213-222	150-153
Steering column and gear as- sembly .....	542-545	290,291
Steering hydraulic pump as... sembly .....	530-541	288-290
Steering knuckle and shaft as- sembly .....	546-549	294, 295
Stoplight switch.....	121	106
Temperature gage and thermo- stat sending unit .....	109	99
Thermostat and thermostat.... cover .....	150	115
Torque rod assembly .....	558-561	297,298

	Paragraph	Page
Carrier-Continued		
Transfer case assembly .....	474-477	269-273
Transmission assembly .....	470-473	257-264
Turn signal switch .....	122	107
Valve, trailer brake .....	518-521	285,286
Valve assembly, air brake check .....	494-497	279
Valve assembly, treadle .....	510-513	283
Valve clearance adjustment...	171	124
Valve cover .....	170	123
Warning light and sending unit, water temperature.....	108	99
Water pump, fan pulley, and hydraulic steering pump.....	149	114
Chain guards, gear guards and....	197	138
Choke control, throttle control and	96	87
Clearance lights:		
Carrier .....	123	108
Crane .....	142	112
Clutches:		
Adjustments .....	178,185	127,132
Engine, carrier .....	442-445	248,249
Engine, crane .....	335-338	211
Hoist drum shaft .....	189	136
Hoist shaft, boom .....	186	132
Power load lowering .....	190	136
Reversing shaft, horizontal ....	187,188	135, 136
Clutch cylinder assemblies, crane hydraulic master cylinder assem- blies and .....	582-588	308,309
Clutch housing, carrier engine	438-441	246, 247
Connecting rod assemblies, piston and:		
Carrier engine .....	434-437	244-246
Crane engine - .....	354-357	218-221
Control rod, transmission .....	245	166
Controls and instruments:		
Carrier .....	14	22
Crane .....	15	27
Conversion for crane operation		11
Coolant lines, hoses, and fittings engine heater:		
Carrier .....	269	181
Crane.....	280	186
Countershaft assembly, crane ....	593-596	312
Crane:		
Air cleaner, engine .....	91	81
Batteries .....	130	109
Belt, generator .....	131	109
Boom and pulleys .....	202	141
Cab removal .....	296	196
Cab wiring harness .....	143	112
Carburetor assembly .....	93, 299- 302	83,198, 199
Clutch adjustment, engine.....	185	132
Controls and instruments.....	15,96, 135	27,87, 110
Crankcase filer and breather..	165	122
Distributor assembly .....	125, 126 323-326	108,206
Engine, removal .....	297	196

	Paragraph	Page
Crane-Continued.....		
Filters, engine oil .....	164	121
Fuel pump .....	95	85
Fuel tank .....	92	81
Gantry frame .....	625-628	322
Generator regulator .....	134	110
Generator assembly .....	131-134, 311-314	109,110, 204
Governor assembly .....	94,303- 306	83,199
Heaters, cab and engine .....	31, 32, 570-581	38,303 308
Hoist drum haft .....	5 89-592	310,311
Horn .....	140	111
Hydraulic cylinder .....	180,183, 582-588	129-131, 308,309
Lights .....	139,141, 142	111,112
Manifolds and muffler .....	175,176	125, 126
Oil pressure relief valve, engine	166	122
Oil pressure sending unit .....	136	110
Operation .....	20	32
Radiator, home, thermostat,... shroud, fan, fan guard, fan.. belt, water pump .....	153-158	117-119
Rotating frame and ring gear	617-624	319-321
Shaft assemblies .....	593-615	312-319
Slave receptacle .....	138	111
Spark plugs and cables .....	127	108
Starter assembly .....	128,129, 319-322	108,109, 206
Valve adjustment .....	173,174	124,125
Water temperature sending... unit .....	137	110
Crankshaft assembly:.....		
Carrier engine .....	462-465	255,256
Crane engine .....	374,377	269-273
Cylinders:.....		
Clutch, hoist drum shaft, crane	181	130
Master, crane .....	180	129
Steering .....	538-541	290
Cylinder head assembly and valves:		
Carrier engine .....	422-425	240
Crane engine .....	339-345	212-215
Daily preventive maintenance serv- ices .....	38	58
Data, tabulated .....	6	8
Defrosters and heater ducts:.....		
Carrier .....	271	181
Crane.....	282	187
Demolition to render the equipment inoperative .....	630	323
Demolition by explosives or weap- on's fire .....	631	323
Description .....	3	5
Detailed lubrication information ...	36	41
Differences in models .....	5	8
AGO 6819A		

	Paragraph	Page
Differential assemblies, carrier ....	550-553, 566-569	295, 299-301
Carrier .....	98,99, 398-401	89, 233, 234
Crane .....	125,126, 323-326	108,206
Domelight, carrier .....	118	104
Door, operator's:		
Carrier .....	255	174
Crane .....	209	146
Drag link carrier .....	220	151
Drive chain, and drive gear, pri- mary drive case cover .....	196	138
Electric coolant pump, engine heater:		
Carrier .....	26	181
Crane .....	279	185
Engine air cleaner:		
Carrier .....	84	75
Crane .....	91	81
Engine crankcase filler and breather:		
Carrier .....	160	120
Crane.....	165	122
Engine governor:		
Carrier .....	86	76
Crane .....	93	83
Engine oil filter:		
Carrier .....	161	121
Crane .....	164	121
Engine oil pressure relief valve:		
Carrier .....	162	121
Crane .....	166	122
Equaling beam assembly .....	562,565	298,299
Equipment, tools and .....	34	41
Exhaust manifolds, intake and:		
Carrier .....	169	122
Crane .....	176	126
Fan and fan belt:		
Carrier .....	145, 146	113
Crane - .....	157	118
Fan guard, crane .....	156	118
Fan pulley and hydraulic steering pump, water pump, carrier .....	149	114
Fenders.....	259-261	176
Filter, engine oil:		
Carrier .....	161	121
Crane .....	164	121
Fire extinguisher .....	38	39
Flood lights, crane.....	141	111
Floorboard, cab .....	256	175
Flywheel and flywheel housing:		
Carrier engine .....	446-449	249
Crane engine .....	358-361	221
Fresh air heater .....	576-581	307, 308
Fuel pump:		
Carrier .....	88	77
Crane .....	95	85
Fuel tanks, lines, and fittings:		
Carrier .....	85	76
Crane .....	92, 81, 307-310	201, 202

	Paragraph	Page
Gage, air pressure, carrier .....	233	162
Gantry frame, crane .....	625-628	322
Gear guards and chain guards ....	197	138
General lubrication information ....	35	41
General methods used to attain... proper suppression .....	79	72
Generator, regulator:.....		
Carrier .....	106	96
Crane .....	134	110
Generator assembly:.....		
Carrier .....	104-106, 390-393	96,232, 232
Crane .....	131-134, 311-314	109,110, 204
Governor assembly:.....		
Carrier engine .....	87, 386-389	77,231
Crane engine .....	94, 303-306	83,199
Handbrake, carrier .....	498-501	279-281
Headlight, carrier .....	117	104
Heaters:.....		
Cab .....	30,82, 270, 281, 576-581	38, 181, 187, 307, 308
Engine .....	29, 31, 267, 278, 570-575	38,180, 185, 303-307
Heater control boxes:.....		
Carrier .....	266	177
Crane .....	277	185
Heater ducts and defrosters:.....		
Carrier .....	271	181
Crane .....	282	187
Heater fuel pump: .....		
Carrier .....	263-265	177
Crane .....	274, 275	184
High beam indicator light assembly, carrier .....	111	101
Hoist drum shaft .....	589-592	310,311
Hoist drum shaft clutch.....	189	136
Hoist drum shaft clutch hydraulic cylinders .....	181	130
Hood and side panel, engine.....	258	175
Horizontal reversing shaft assembly	601-604	315
Horizontal reversing shaft clutches		187,188
Horn assembly:.....		
Carrier .....	112,119	102,105
Crane .....	140	111
Hoses, lines and fittings:.....		
Heater, engine coolant, crane	280	186
Heater, engine coolant, carrier		269
Air, carrier .....	232	161
Hydraulic control valve assembly, carrier steering .....	534-537	289, 290
Hydraulic cylinder assembly, car.. rier steering .....	538-541	290
Hydraulic master cylinder assem- blies and clutch cylinder assem- blies, crane .....	582-588	308,309

	Paragraph	Page
Hydraulic pump assembly, carrier steering .....	530-533	288,289
Hydraulic steering pump, carrier...	213	150
Hydraulic steering pump belt, car rier .....	145	113
Hydraulic steering pump, water pump, fan pulley, and carrier.....	149	114
Identification and tabulated data..	4	5
Indicator, boom angle .....	207	145
Inspecting and servicing new equip- ment .....	9	14
Inspection and maintenance of equipment in storage .....	637	327
Installation or setting-up instruc- tions .....	10	17
Instrument panel components:		
Carrier .....	107	99
Crane .....	135, 315-318	110, 204-206
Intake and exhaust manifolds:		
Carrier .....	169	122
Crane .....	176	126
Interference suppression compo- nents .....	80	73
Jaw clutch lever linkage .....	202	141
Lights, carrier .....	110,111, 114-118, 123	99,101, 102-104, 108
Linkage, Jaw clutch lever .....	202	141
Liquid heater repair instructions, carrier engine and crane engine		570-575
Load rollers:		
Front .....	199	139
Rear .....	200	141
Loading equipment for shipment..	635	326
Lubrication information:		
Detailed .....	36	41
General .....	35	41
Main bearings, carrier engine crankshaft and .....	462-465	255,256
Maintenance of equipment in stor- age .....	135, 136	637
Manifolds, water .....	151	116
Master cylinders, crane .....	180	129
Moisture ejector valve assembly, car- rier .....	237, 490-493	163,278
181 Mount and pulley assembly, crane engine .....	362-365	222-224
Moving crane with boom installed	21	35
Muffler and pipe:		
Carrier .....	168	122
Crane .....	175	125
New equipment, Inspecting and servicing .....	9	14

	Paragraph	Page
Oil cooler, carrier engine oil alter.. base and .....	414-417	237,238
Oil pan and filler blocks:.....		
Carrier engine .....	426-429	241,242
Crane engine - .....	346-349	216
Oil pressure relief valve, engine:..		
Carrier .....	162	121
Crane .....	166	122
Oil pressure sending unit, safety.. switch and pressure switch, crane	136	110
Oil pump assembly: .....		
Carrier engine .....	430-433	243, 244
Crane engine .....	350-353	217, 218
Operation:.....		
At high altitudes .....	27	38
Carrier .....	19	32
Crane .....	20	32
In dusty or sandy areas.....	24	36
In extreme cold, below 0° F. .	22	35
In extreme heat .....	23	36
In salt-water areas .....	26	37
Under rainy or humid condi- tions .....	25	37
Other demolition methods .....	632	325
Outrigger assemblies .....	249	171
Panel light assembly, carrier .....	110	99
Pintle hook .....	248	170
Piston and connecting rod..... assemblies:.....		
Carrier engine .....	434-437	244-246
Crane engine .....	354-357	218-221
Power load lowering clutch.....	190	136
Preparation of equipment:.....		
Shipment .....	636	326
Storage .....	634	325
Preventive maintenance services:		
Daily .....	38	58
General .....	37	58
Quarterly .....	39	62
Primary drive chain case cover, ... drive chain, and drive gear.....	196	138
Pump: .....		
Electric coolant, engine heater	268,279	181,185
Fuel .....	88	77
Fuel, carrier heater .....	263-265	177
Fuel, crane heater .....	274,275	184
Hydraulic steering .....	149,213, 530-533	114,150, 288,289
Oil, carrier engine .....	430-433	243, 244
Oil, crane engine .....	350-353	217,218
Water .....	149,158, 410-413	114,119, 236, 237
Push rods assembly, carrier engine rocker arm and .....	418-421	238-240
Quarterly preventive maintenance services .....	39	62
Quick release valve, carrier.....	235	162

	Paragraph	Page
Radiator assembly:		
Carrier .....	147,272, 406-409	113, 181, 235, 236
Crane .....	156,283, 327-330	118, 188, 207
Radio interference suppression....	79-82	72-75
Record and report forms .....	2	5
Relay valve .....	238	163
Removal instructions:		
Carrier engine assembly .....	298	197
Crane cab assembly .....	296	196
Crane engine assembly .....	297	196
Repair and replacement standard	287	189
Repair instructions, servicing:		
Bearings .....	289	194
Brake and clutch linings.....	295	195
Bushings .....	291	195
Gears .....	293	195
Oil seals .....	290	195
Shafts .....	292	195
Shims .....	294	195
Report forms, records and .....	2	5
Rocker arm and pushrods assembly, carrier engine .....	418-421	238-240
Rotating frame base assembly, crane .....	617-620	319-321
Ring gear rotating frame .....	621-624	321
Safety ratchet assembly .....	201	141
Seat, operator's:		
Carrier .....	254	174
Crane .....	211	149
Service shutoff valves, air emer- gency and .....	240	164
Servicing and repair instructions:		
Bearings .....	289	194
Brake and clutch linings.....	290	196
Bushings .....	291	195
Gears .....	292	195
Oil seals .....	293	195
Shafts .....	294	195
Shims .....	295	195
Setting-up instructions, installation		10
Shafts:		
Auxiliary, load lowering .....	613-615	318,319
Boom hoist .....	597-600	313-314
Countershaft assembly .....	539-596	312
Hoist drum .....	589-592	310,311
Propeller, transmission to trans- fer case .....	244	166
Reversing, horizontal .....	601-604	315
Reversing, vertical .....	605-608	316,317
Swing, vertical .....	609-612	317,318
Shaft packing gland, crane .....	182	130
Shifter levers and controls, trans- fer case .....	246	166
Shock absorbers, front .....	229	157
Slave receptacle:		
Carrier .....	120	106
Crane .....	138	111

	Paragraph	Page
Spark plugs and cables:.....		
Carrier .....	100	90
Crane .....	127	108
Spring assembly, carrier front .....	554-557	296, 297
Starter assembly:.....		
Carrier .....	101, 102 394-397	91, 94, 233
Crane .....	128, 129, 319-322	108, 109, 206
Starting and stopping .....	17, 18	31
Stoplight switch, carrier .....	121	106
Steering:.....		
Adjustment .....	218	151
Arm .....	221	151
Pump .....	213	150
Pump pulley .....	214	150
Pump relief valve .....	215	150
Pump reservoir .....	215	150
Tie rod .....	222	153
Valve .....	217	151
Wheel .....	219	151
Steering column and gear assembly.....	542-545	290,291
Steering hydraulic pump assembly .....	530-541	288-290
Steering knuckle and shaft assembly .....	564-549	294, 295
Suppression, radio interference ...	79-82	72-76
Tabulated data-.....	6	8
Testing of radio interference sup- pression components .....	82	75
Thermostat housing and..... thermostats:.....		
Carrier .....	150	115
Crane .....	154, 155	117, 118
Throttle control and choke control, crane .....	96	87
Tie rod, steering, carrier .....	222	153
Timing gears and timing gear..... cover:.....		
Carrier .....	454-457	252
Crane .....	366-369	224
Tires and tubes .....	228	156
Tools and equipment .....	34	41
Torque rod assembly .....	558-561	297,298
Tractor protection valve .....	236	163
Trailer brake valve, carrier .....	518-521	285,286
Transfer case assembly, carrier ..	474-477	269-273
Transfer case shifter levers and... controls .....	246	166
Transmission assembly, carrier....	470-473	257-264
Transmission control rod .....	245	166
Treadle valve assembly, carrier ..	510-513	283
Trouble light and reel, pistol grip- Troubleshooting:	139	109
Brakes grab when pedal is.... depressed .....	73	71
Brakes release too slowly with pedal released .....	71	71
Cables tend to flatten .....	63	70
Carrier gear shifting difficult ...	75	72
Carrier handbrake does not hold when applied.....	69	71

	Paragraph	Page
Troubleshooting-Continued		
Carrier has no brake action, insufficient action or brakes apply slowly .....	70	71
Carrier rear axle and tandem unit noisy .....	78	72
Carrier transfer case noisy.....	76	72
Carrier transmission and trans- fer case overheats .....	77	72
Carrier transmission excessive- ly noisy in operation.....	74	72
Continuous humming noise or noisy front axle when driving .....	65	70
Crane boom or hoist operation rough .....	60	70
Crane hoist gears noisy.....	60	70
Crane swing gear noisy or pulsations in operation.....	61	70
Engine clutch drags .....	54	69
Engine clutch noisy .....	53	69
Engine clutch slips or will not engage properly .....	55	69
Engine fails to start or is hard to start .....	43	67
Engine knocks and other noises	51	69
Engine lacks power .....	41	67
Engine miss or vibrates excel- sively .....	44	68
Engine oil consumption high..	52	69
Engine oil pressure low.....	50	69
Engine over heats .....	46	68
Engine stalls frequently.....	45	68
Engine starts but will not run..	49	68
Engine temperature fails to rise .....	48	68
Excessive black smoke from exhaust .....	47	68
Fuel consumption excessive..	56	69
General.....	40	67
Improper air pressure .....	68	71
Lights fail .....	57	69
Lights dim .....	58	69
One brake drags with pedal released .....	72	71
Primary drive chain exces- sively noisy .....	59	70
Revolving frame teeters or will not swing .....	64	70
Starters fail to operate .....	42	67
Steering assembly cracks when turning .....	66	70
Steering head .....	67	71
Tubes and fittings:		
Carrier .....	148	114
Crane .....	153, 183	117, 181
Turn signal switch, carrier .....	122	107
Unloading crane-shovel.....	7	14
Unpacking new equipment.....	8	14

	Paragraph	Page		Paragraph	Page
Valve assemblies:.....			Water manifolds, carrier.....	161	116
Air emergency and service.....			Water pump assembly:		
shutoff .....	240	164	Carrier .....	149,410-	114,236,
Check air brake.....	494-497	279	.....	413	237
Clearance adjustment.....	171,174	124,125	Crane .....	158	119
Control, steering .....	534-537	289-294	Water temperature warning light		
Moisture ejector .....	237,490-493	163,278	and sending unit:		
Oil pressure relief, engine .....	162,166	121,122	Carrier .....	108	99
Protection, air brake .....	514-517	285	Crane.....	137	110
Quick release, air brake .....	514-517	285	Wheel, front and rear.....	224, 226	154,155
Quick release, carrier.....	235	162	Wheel bearings .....	225, 227	154,155
Relay .....	238	163	Windows:		
Steering .....	216,217	150,151	Carrier .....	251, 252	173
Tractor protection .....	236	163	Crane .....	210	146
Trailer, brake .....	518-521	285,286	283 Windshield wiper:		
Treadle .....	510-513		Carrier .....	257	175
Valves, cylinder head assembly end:			Crane .....	284,285	188
Crane engine .....	422-425	240	Wiring harness:		
Crane engine .....	339-345	212-215	Carrier .....	113	102
Vertical reversing shaft assembly.	605-608	316,317	Crane .....	143, 315	112,204-
Vertical wing shaft assembly .....	609-612	317,318	.....	318	206
Vibration damper and pulley.....					
assembly, carrier engine .....	450-453	251			

AGO 6819A



By Order of the Secretary of the Army:

Official:

HAROLD K. JOHNSON,  
*General, United States Army,  
Chief of Staff.*

J. C. LAMBERT  
*Major General, United States Army,  
The Adjutant General.*

Distribution:

*Active Army:*

USASA (2)	GENDEP (OS) (10)
ACSI (1)	Engr Dep (0) (10)
DCSLOG (1)	Army Dep (2)
CNGB (1)	USA Trans Tml Comnd (2)
TSG (1)	USA Tml (1)
CofEngrs (1)	USAOSA (2)
C/COMMEL (1)	Div Engr (2)
CofT (1)	Engr Dist (2)
CofSptsS (1)	USAERDL(3)
USA Maint Bd (1)	USA Mbl Equip Cen (46)
USAARTYBD(2)	Engr Cen (5)
USAARMBD (2)	USAREUR Engr Proc Cen (2)
USAIB (2)	USAREUR Engr Sup Con Agcy (10)
USAADB (2)	Chicago Proc Ofc (10)
USAAESWBD (2)	Engr Fld Maint Shops (2)
USAAVNBD (2)	Fld Comd, DASA (8)
USCONARC (3)	AMS (8)
OS Maj Comd (5) except	USAREURCOMZ (2)
USASETAF (2) USARJ (10)	USA Corps (1)
USAMOCOM -(2)	MAAG (1)
USASMCOM (1)	JBUSMC (1)
MDW (1)	Units org under fol TOE: (2 ea UNOINDC)
Armies (2)	5-48
Corps (2)	5-237 (5)
Div (2)	5-262 (5)
Engr Bde (1)	5-267 (1)
Svc College. (2)	5-278 (5)
Br Svc Sch (2) except	5-279
USAES (100)	5-500 EA, EB
USMA (2)	

NG: State AG (8).

USAR: Same as active Army except allowance is one copy to each unit.

For explanation of abbreviations used, see AR 820-60.

AGO 6819A

RECOMMENDED CHANGES TO EQUIPMENT TECHNICAL PUBLICATIONS

 <p style="font-style: italic; text-align: center;">THEN...JOT DOWN THE DOPE ABOUT IT ON THIS FORM. CAREFULLY TEAR IT OUT, FOLD IT AND DROP IT IN THE MAIL.</p>		SOMETHING WRONG WITH PUBLICATION		
		FROM: (PRINT YOUR UNIT'S COMPLETE ADDRESS)		
PUBLICATION NUMBER		DATE SENT		
PUBLICATION DATE		PUBLICATION TITLE		
BE EXACT PIN-POINT WHERE IT IS				
PAGE NO.	PARA- GRAPH	FIGURE NO.	TABLE NO.	<p style="font-weight: bold; text-align: center;">IN THIS SPACE, TELL WHAT IS WRONG AND WHAT SHOULD BE DONE ABOUT IT.</p>
PRINTED NAME, GRADE OR TITLE AND TELEPHONE NUMBER			SIGN HERE	

## The Metric System and Equivalents

### Linear Measure

1 centimeter = 10 millimeters = .39 inch  
 1 decimeter = 10 centimeters = 3.94 inches  
 1 meter = 10 decimeters = 39.37 inches  
 1 dekameter = 10 meters = 32.8 feet  
 1 hectometer = 10 dekameters = 328.08 feet  
 1 kilometer = 10 hectometers = 3,280.8 feet

### Weights

1 centigram = 10 milligrams = .15 grain  
 1 decigram = 10 centigrams = 1.54 grains  
 1 gram = 10 decigrams = .035 ounce  
 1 decagram = 10 grams = .35 ounce  
 1 hectogram = 10 decagrams = 3.52 ounces  
 1 kilogram = 10 hectograms = 2.2 pounds  
 1 quintal = 100 kilograms = 220.46 pounds  
 1 metric ton = 10 quintals = 1.1 short tons

### Liquid Measure

1 centiliter = 10 milliliters = .34 fl. ounce  
 1 deciliter = 10 centiliters = 3.38 fl. ounces  
 1 liter = 10 deciliters = 33.81 fl. ounces  
 1 dekaliter = 10 liters = 2.64 gallons  
 1 hectoliter = 10 dekaliters = 26.42 gallons  
 1 kiloliter = 10 hectoliters = 264.18 gallons

### Square Measure

1 sq. centimeter = 100 sq. millimeters = .155 sq. inch  
 1 sq. decimeter = 100 sq. centimeters = 15.5 sq. inches  
 1 sq. meter (centare) = 100 sq. decimeters = 10.76 sq. feet  
 1 sq. dekameter (are) = 100 sq. meters = 1,076.4 sq. feet  
 1 sq. hectometer (hectare) = 100 sq. dekameters = 2.47 acres  
 1 sq. kilometer = 100 sq. hectometers = .386 sq. mile

### Cubic Measure

1 cu. centimeter = 1000 cu. millimeters = .06 cu. inch  
 1 cu. decimeter = 1000 cu. centimeters = 61.02 cu. inches  
 1 cu. meter = 1000 cu. decimeters = 35.31 cu. feet

## Approximate Conversion Factors

<i>To change</i>	<i>To</i>	<i>Multiply by</i>	<i>To change</i>	<i>To</i>	<i>Multiply by</i>
inches	centimeters	2.540	ounce-inches	Newton-meters	.007062
feet	meters	.305	centimeters	inches	.394
yards	meters	.914	meters	feet	3.280
miles	kilometers	1.609	meters	yards	1.094
square inches	square centimeters	6.451	kilometers	miles	.621
square feet	square meters	.093	square centimeters	square inches	.155
square yards	square meters	.836	square meters	square feet	10.764
square miles	square kilometers	2.590	square meters	square yards	1.196
acres	square hectometers	.405	square kilometers	square miles	.386
cubic feet	cubic meters	.028	square hectometers	acres	2.471
cubic yards	cubic meters	.765	cubic meters	cubic feet	35.315
fluid ounces	milliliters	29.573	cubic meters	cubic yards	1.308
pints	liters	.473	milliliters	fluid ounces	.034
quarts	liters	.946	liters	pints	2.113
gallons	liters	3.785	liters	quarts	1.057
ounces	grams	28.349	liters	gallons	.264
pounds	kilograms	.454	grams	ounces	.035
short tons	metric tons	.907	kilograms	pounds	2.205
pound-feet	Newton-meters	1.356	metric tons	short tons	1.102
pound-inches	Newton-meters	.11296			

## Temperature (Exact)

°F	Fahrenheit temperature	5/9 (after subtracting 32)	Celsius temperature	°C
----	---------------------------	-------------------------------	------------------------	----

